

Swing-gate gearmotor

FA02103-EN

CE

EAC



ATS30AGS

ATS50AGS

ATS30AGR

ATS50AGR

ATS30AGM

ATS50AGM

INSTALLATION MANUAL

EN

English

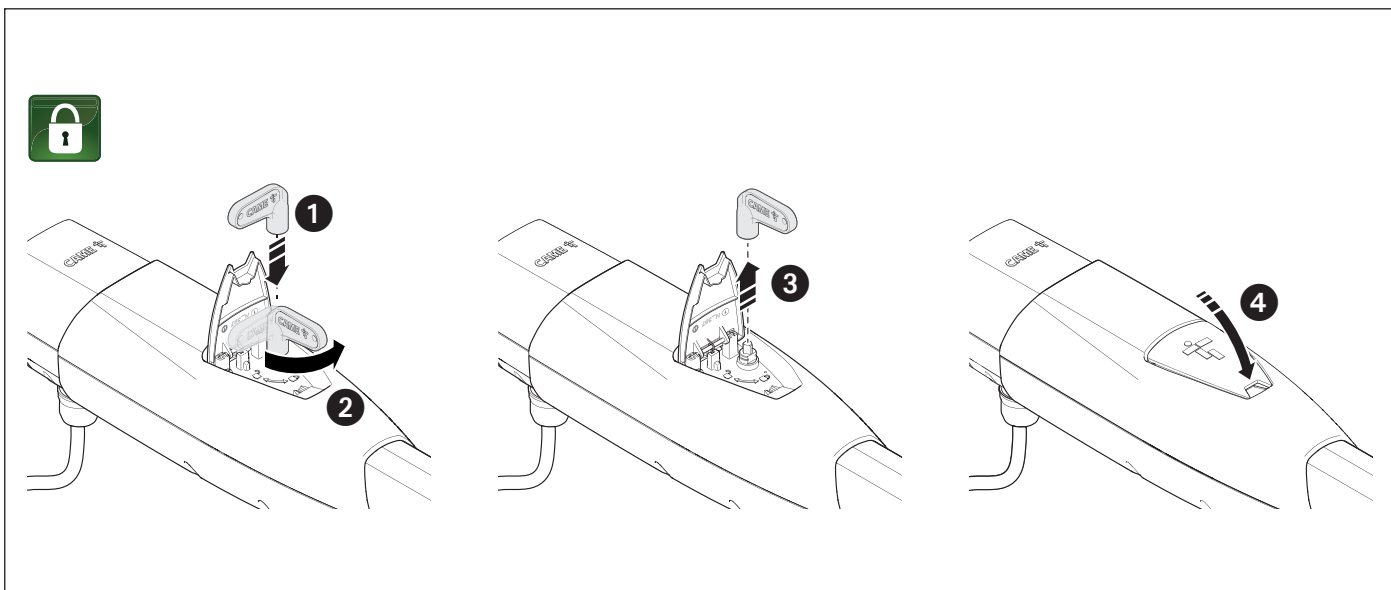
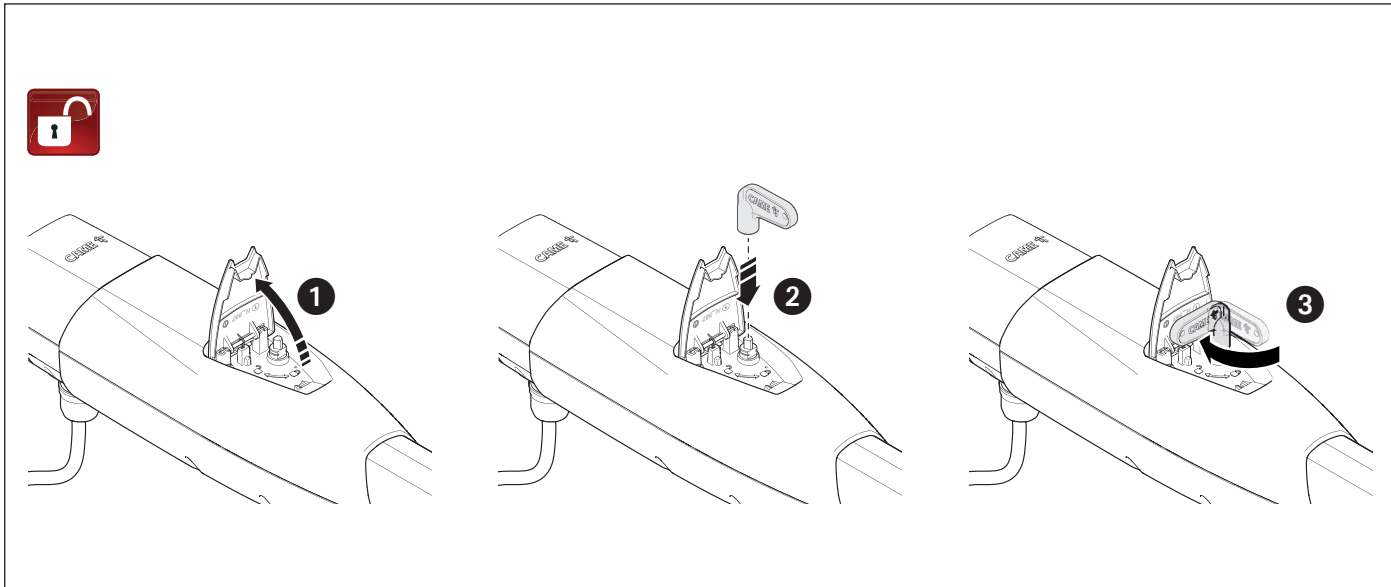

⚠ **Important safety instructions.**

⚠ **Please follow all of these instructions. Improper installation may cause serious bodily harm.**

⚠ **Before continuing, please also read the general precautions for users.**

Only use this product for its intended purpose. Any other use is hazardous.

- The manufacturer cannot be held liable for any damage caused by improper, unreasonable or erroneous use.
- This product is defined by the Machinery Directive (2006/42/EC) as partly completed machinery.
- Partly completed machinery means an assembly which is almost machinery but which cannot in itself perform a specific application.
- Partly completed machinery is only intended to be incorporated into or assembled with other machinery or other partly completed machinery or equipment thereby forming machinery to which the Machinery Directive (2006/42/EC) applies.
- The final installation must comply with the Machinery Directive (2006/42/EC) and the European reference standards in force.
- The manufacturer declines any liability for using non-original products, which would also void the warranty.
- All operations indicated in this manual must be carried out exclusively by skilled and qualified personnel and in full compliance with the regulations in force.
- The device must be installed, wired, connected and tested according to good professional practice, in compliance with the standards and laws in force.
- All the components (e.g. actuators, photocells and sensitive edges) needed for the final installation to comply with the Machinery Directive (2006/42/EC) and with the reference harmonised technical standards are specified in the general CAME product catalogue or on the website www.came.com.
- Make sure the mains power supply is disconnected during all installation procedures.
- Check that the temperature ranges given are suitable for the installation site.
- Do not install the operator on surfaces that could yield and bend. If necessary, add suitable reinforcements to the anchoring points.
- Make sure that no direct jets of water can wet the product at the installation site (sprinklers, water cleaners, etc.).
- Make sure you have set up a suitable dual-pole cut-off device along the power supply that is compliant with the installation rules. It should completely cut off the power supply according to category III surcharge conditions.
- Demarcate the entire site properly to prevent unauthorised personnel from entering, especially minors.
- In case of manual handling, have one person for every 20 kg that needs hoisting; for non-manual handling, use proper hoisting equipment in safe conditions.
- Use suitable protection to prevent any mechanical hazards due to persons loitering within the operating range of the operator.
- The electrical cables must pass through special pipes, ducts and cable glands in order to guarantee adequate protection against mechanical damage.
- The electrical cables must not touch any parts that may overheat during use (such as the motor and transformer).
- Before installation, check that the guided part is in good mechanical condition, and that it opens and closes correctly.
- The product cannot be used to automate any guided part that includes a pedestrian gate, unless it can only be enabled when the pedestrian gate is secured.
- Make sure that nobody can become trapped between the guided and fixed parts, when the guided part is set in motion.
- All fixed controls must be clearly visible after installation, in a position that allows the guided part to be directly visible, but far away from moving parts. In the case of a hold-to-run control, this must be installed at a minimum height of 1.5 m from the ground and must not be accessible to the public.
- If not already present, apply a permanent tag that describes how to use the manual release mechanism close to it.
- Make sure that the operator has been properly adjusted and that the safety and protection devices and the manual release are working properly.
- Before handing over to the final user, check that the system complies with the harmonised standards and the essential requirements of the Machinery Directive (2006/42/EC).
- Any residual risks must be indicated clearly with proper signage affixed in visible areas, and explained to end users.
- Put the machine's ID plate in a visible place when the installation is complete.
- If the power supply cable is damaged, it must be immediately replaced by the manufacturer or by an authorised technical support service, or in any case, by qualified staff, to prevent any risk.
- Keep this manual inside the technical folder along with the manuals of all the other devices used for your automation system.
- Make sure to hand over to the end user all the operating manuals of the products that make up the final machinery.
- The product, in its original packaging supplied by the manufacturer, must only be transported in a closed environment (railway carriage, containers, closed vehicles).
- If the product malfunctions, stop using it and contact customer services at <https://www.came.com/global/en/contact-us> or via the telephone number on the website.
- The manufacture date is provided in the production batch printed on the product label. If necessary, contact us at <https://www.came.com/global/en/contact-us>.
- The general conditions of sale are given in the official CAME price lists.

Main points of danger for people

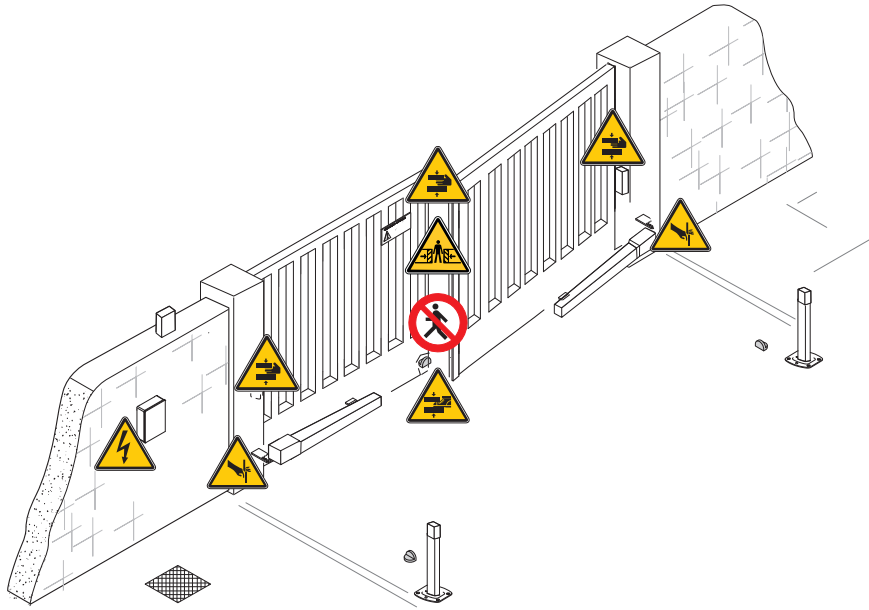

 No transiting while the barrier is moving.

 Risk of entrapment.

 Risk of trapping hands.

 Risk of trapping feet.

 Risk of cutting hands.

DISMANTLING AND DISPOSAL

 CAME S.p.A. employs an Environmental Management System at its premises. This system is certified and compliant with the UNI EN ISO 14001 standard to ensure that the environment is respected and safeguarded. Please continue safeguarding the environment. At CAME we consider it one of the fundamentals of our operating and market strategies. Please follow these brief disposal guidelines:

DISPOSING OF THE PACKAGING

The packaging materials (cardboard, plastic, etc.) can be disposed of easily as solid urban waste, separated for recycling.

Before dismantling and disposing of the product, please always check the local laws in force.

DISPOSE OF THE PRODUCT RESPONSIBLY.

DISPOSING OF THE PRODUCT

Our products are made of various materials. Most of these materials (aluminium, plastic, iron and electrical cables) are classified as solid urban waste. They can be separated for recycling and disposed of at authorised waste treatment plants.





Other components (electronic boards, transmitter batteries, etc.) may contain pollutants.

These must be removed and disposed of by an authorised waste disposal and recycling firm.

It is always advisable to check the specific laws that apply in your area.

DISPOSE OF THE PRODUCT RESPONSIBLY.

Key

-  This symbol shows which parts to read carefully.
-  This symbol shows which parts describe safety issues.
-  This symbol shows what to tell users.
-  The measurements, unless otherwise stated, are in millimetres.

Description

801MP-0050

ATS30AGS - Irreversible telescopic gearmotor 230 V for swing gates with Max. C 200 mm with leaf up to 3 m and 400 kg. Grey RAL7024.

801MP-0060

ATS50AGS - Irreversible telescopic gearmotor 230 V for swing gates with Max. C 200 mm with leaf up to 5 m and 400 kg. Grey RAL7024.

801MP-0090

ATS30AGR - Irreversible telescopic gearmotor 230 V for swing gates with Max. C 200 mm, with remote release, for leaves up to 3 m and 400 kg. Grey RAL7024.

801MP-0100

ATS50AGR - Irreversible telescopic gearmotor 230 V for swing gates with Max. C 200 mm, with remote release, for leaves up to 5 m and 400 kg. Grey RAL7024.

801MP-0120

ATS30AGM - Irreversible telescopic gearmotor 230 V for swing gates with C max. 200 mm with leaf up to 3 m and 400 kg, for applications also at low temperatures. Grey RAL7024.

801MP-0150

ATS50AGM - Irreversible telescopic gearmotor 230 V for swing gates with C max. 200 mm with leaf up to 5 m and 400 kg, for applications also at low temperatures. Grey RAL7024.

Intended use

Solutions for applications in residential buildings and apartment blocks

-  Any installation and/or use other than that specified in this manual is forbidden.

Description of parts

Gearmotor

- ❶ Gate bracket
- ❷ Door to access the end-of-travel adjustment screws
- ❸ Door to access the release mechanism
- ❹ Sheath connector
- ❺ Pillar bracket
- ❻ Release key
- ❼ Release cord*
- ❽ Cutting hazard labels

* ATS30AGR * ATS50AGR

Not to be sold separately. Check motor availability in your country.

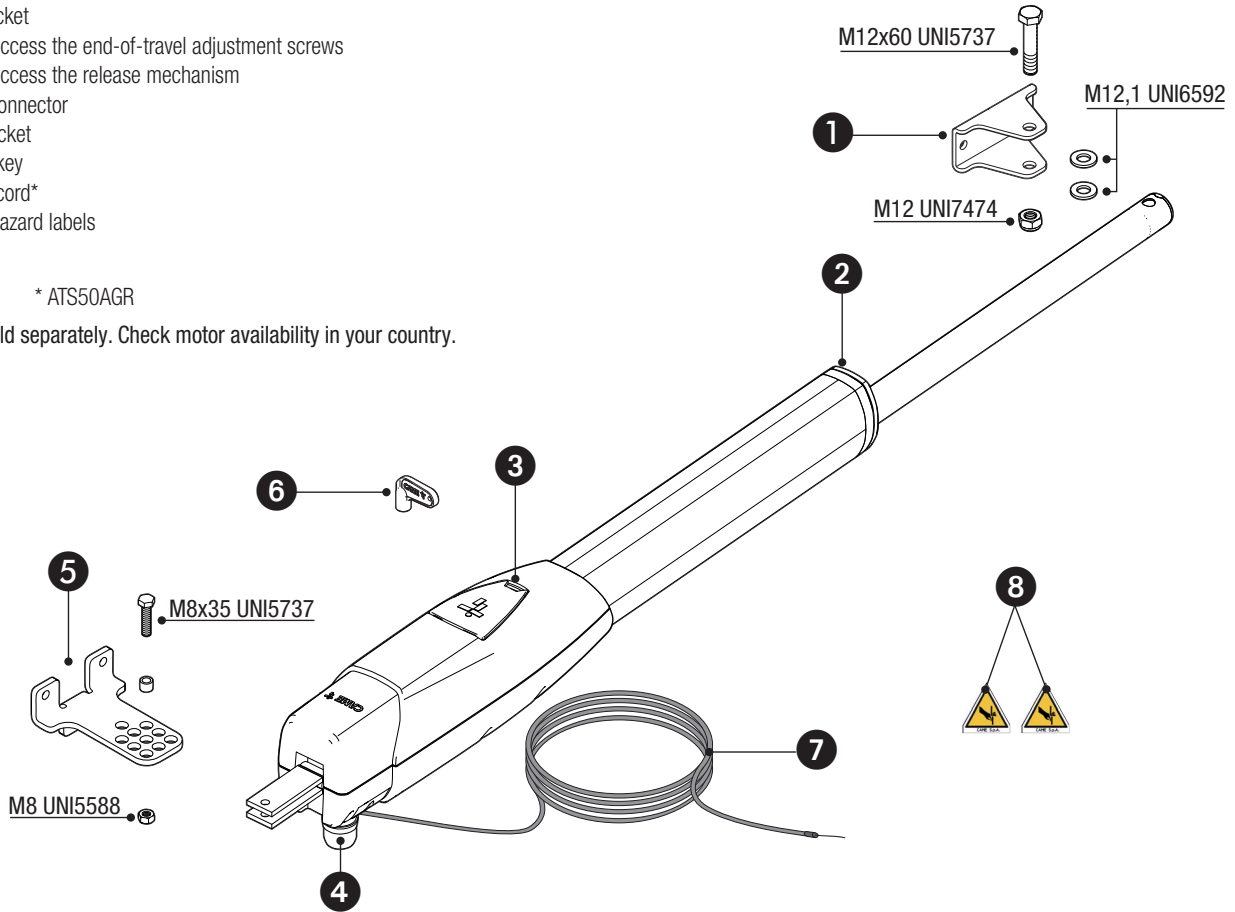

Size

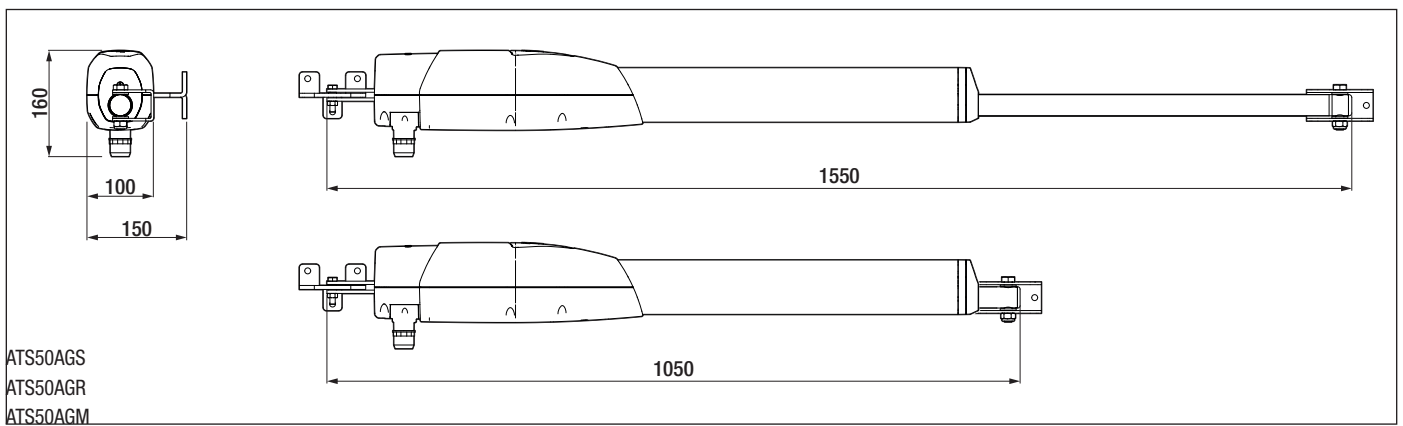
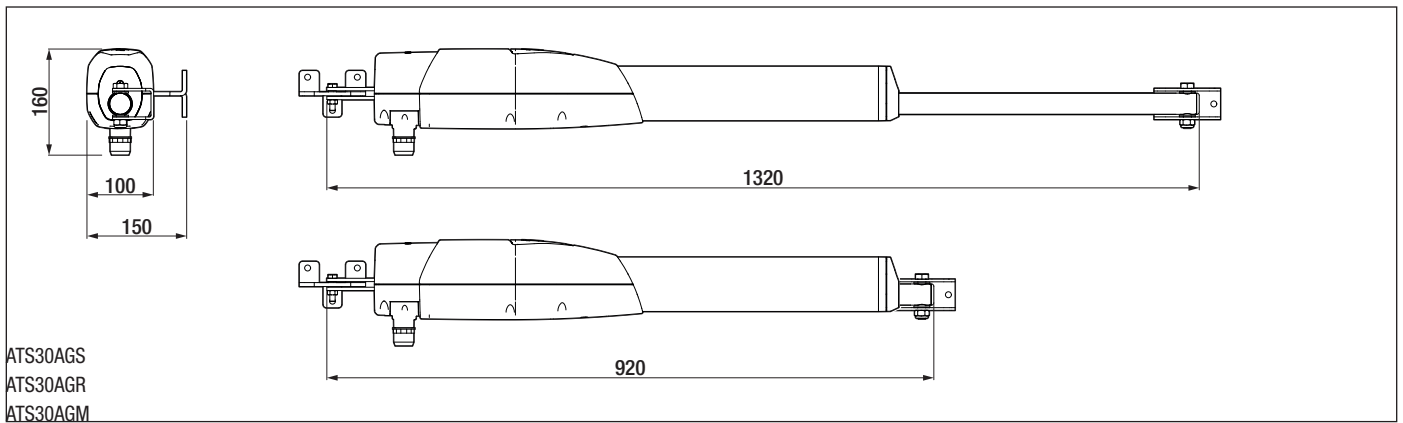

Usage limitations

MODELS	ATS30AGS / ATS30AGR / ATS30AGM		
Gate-leaf length (m)	3	2,5	2
Leaf weight (kg)	400	600	800

MODELS	ATS50AGS / ATS50AGR / ATS50AGM				
Gate-leaf length (m)	5	4	3	2,5	2
Leaf weight (kg)	400	500	600	800	1000

⚠ For swing gates, installing an electric lock is always recommended. This is to ensure the leaves close reliably and to protect the gearmotor parts.

It is also recommended for irreversible gearmotors – and is mandatory where the leaves are more than 2.5 m in length.

For reversible gearmotors, electric locks are required to ensure the leaves close. The installer is responsible for installing an electric lock, taking into account the size and type of leaf (e.g. panelled) and the installation area (e.g. windy location).

Technical data

MODELS	ATS30AGS	ATS50AGS	ATS30AGR	ATS50AGR	ATS50AGM	ATS30AGM
Motor power supply (V)	230 AC	230 AC	230 AC	230 AC	230 AC	230 AC
Power (W)	250	250	250	250	250	250
Capacitor (µF)	8	8	8	8	8	8
Current draw (A)	1	1	1	1	1	1
Operating temperature (°C)	-20 ÷ +55	-20 ÷ +55	-20 ÷ +55	-20 ÷ +55	-20 ÷ +55	-20 ÷ +55
Storage temperature (°C)*	-20 ÷ +70	-20 ÷ +70	-20 ÷ +70	-20 ÷ +70	-20 ÷ +70	-20 ÷ +70
Thrust (N)	400 ÷ 3000	400 ÷ 3000	400 ÷ 3000	400 ÷ 3000	400 ÷ 3000	400 ÷ 3000
Opening time at 90° (s)	15	20	15	20	20	15
Sound pressure level (dB A)	≤70	≤70	≤70	≤70	≤70	≤70
Protection rating (IP)	54	54	54	54	54	54
Insulation class	I	I	I	I	I	I
Reduction ratio (i)	28	28	28	28	28	28
Weight (kg)	8.5	9	8.5	9	9	8.5
Average life (cycles)**	120.000	120.000	120.000	120.000	120.000	120.000

(*) Before installing the product, keep it at room temperature where it has previously been stored or transported at a very high or very low temperature.

(**) The average product life specified should be understood purely as an indicative estimate. It applies to normal usage conditions and where the product has been installed and maintained in compliance with the instructions provided in the CAME technical manual. The average product life is also affected, including significantly, by other variables such as, but not limited to, climatic and environmental conditions (where present, see the MCBF table). The average product life should not be confused with the product warranty.

Operating cycles

MODELS	ATS30AGS	ATS50AGS	ATS30AGR	ATS50AGR	ATS30AGM	ATS50AGM
Cycles/hour (no.)	20	20	20	20	20	20
Consecutive cycles (no.)	10	10	10	10	10	10

📖 The cycles calculation applies to gates that are professionally installed, free of any mechanical issues and/or accidental friction points, and measured at 20°C, as stated in EN Standard 60335-2-103.

Cable types and minimum thicknesses

Cable length (m)	up to 20	from 20 to 30
Power supply 230 V AC	3G x 1.5 mm ²	3G x 2.5 mm ²
Motor power supply 230 V AC	4G x 1.5 mm ²	4G x 2.5 mm ²

📖 When operating at 230 V and outdoors, use H05RN-F cables compliant with 60245 IEC 57 (IEC); when indoors, use H05VV-F cables compliant with 60227 IEC 53 (IEC). For power supplies up to 48 V, use FROR 20-22 II cables compliant with standard EN 50267-2-1 (CEI).

📖 If the cable lengths differ from those specified in the table, define the cable cross-sections according to the actual power draw of the connected devices and in line with regulation CEI EN 60204-1.

📖 For multiple, sequential loads along the same line, recalculate the values in the table according to the actual power draw and distances. For information on connecting products not covered in this manual, please see the documentation accompanying the products themselves.

INSTALLATION

 The following illustrations are examples only. The space available for fitting the operator and accessories varies depending on the area where it is installed. It is up to the installer to find the most suitable solution.

 The drawings refer to a gearmotor installed on the left-hand side.

Preliminary operations

Prepare the junction boxes and corrugated tubes you need for the connections from the junction pit.

 The number of tubes depends on the type of system and the accessories that are going to be fitted.

 We recommend positioning mechanical stops on the ground for safety reasons. If this is not possible, use the limit switches on the gearmotor.

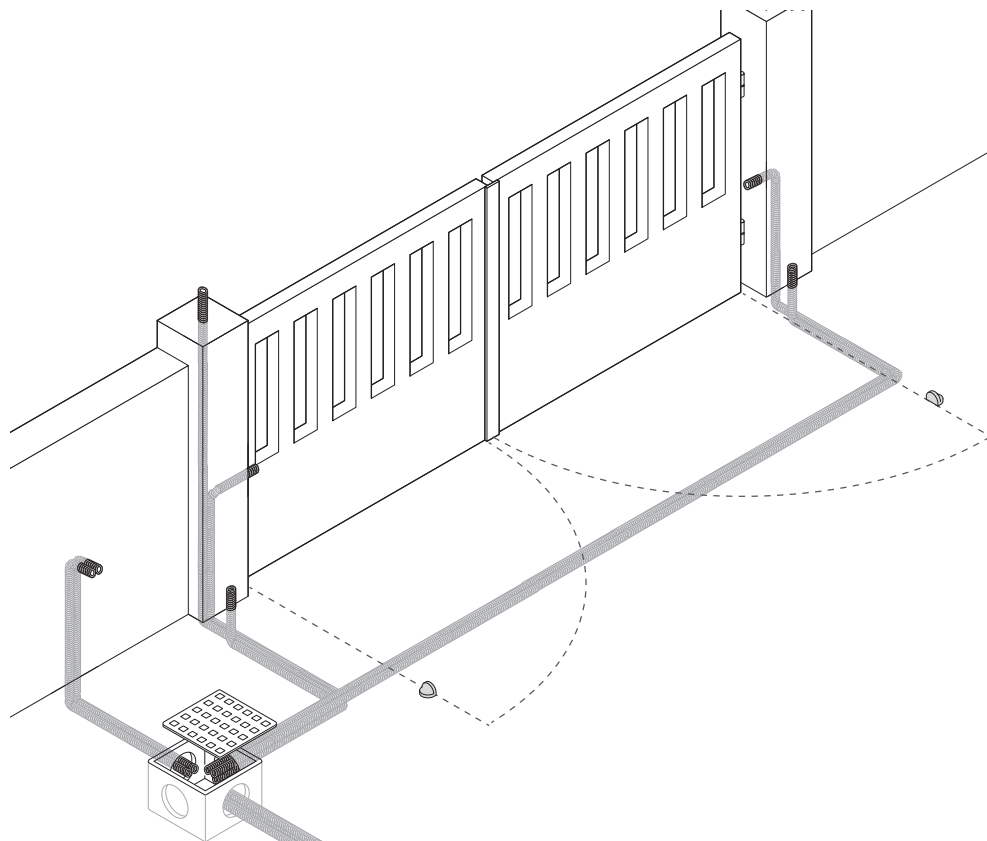

Deciding where to fasten the brackets

⚠ The gate should be open when taking the measurements for determining where the brackets should be fixed. If this is not possible, take the measurements with the gate closed.

Manually open the gate leaf to 90° or 120°.

Identify the position where the gate bracket will be fixed (at a suitable height from the ground), then the position of the post bracket, respecting the measurements given in the figure below.

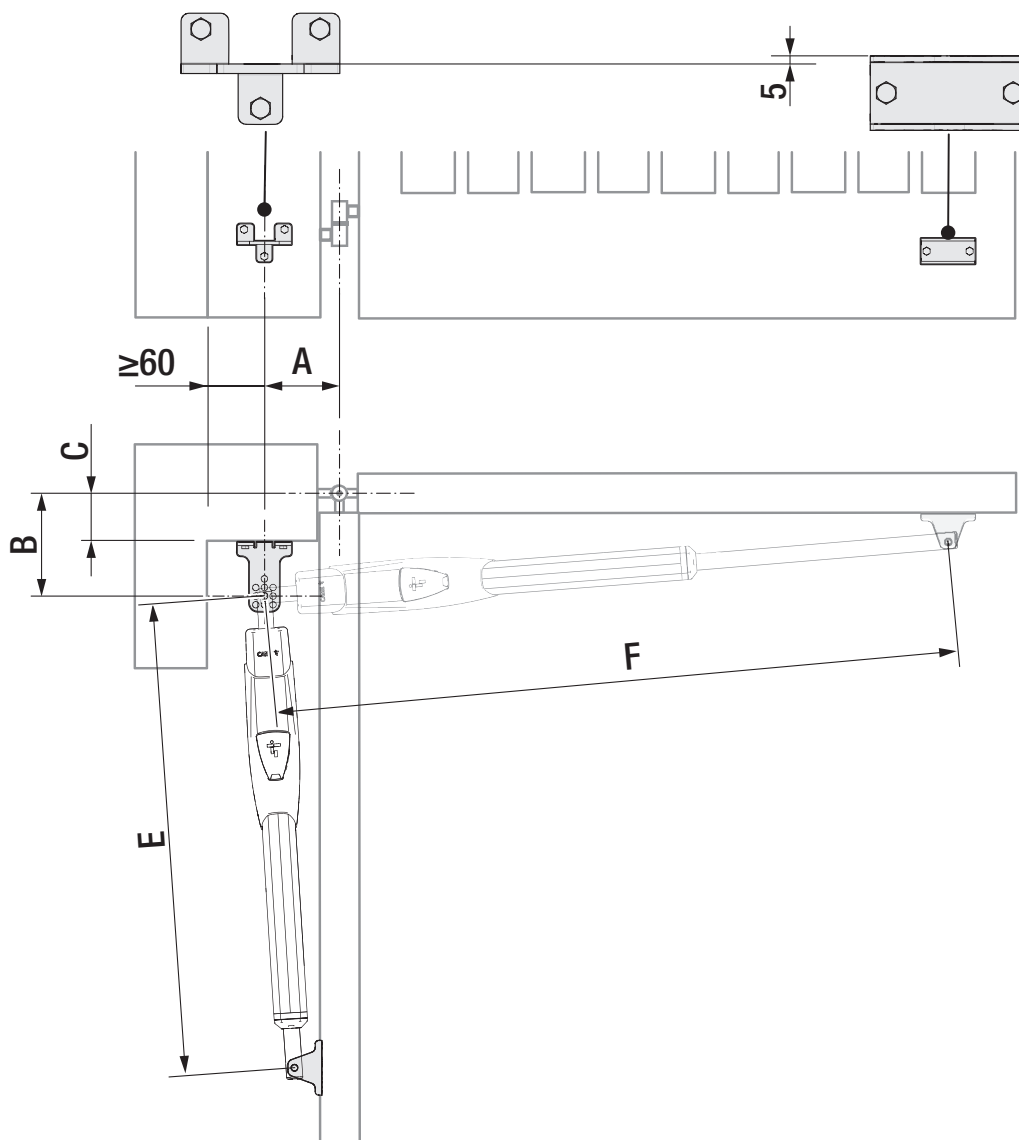

ATS30AGS ATS30AGR ATS30AGM

Gate-leaf opening (°)	A	B	E	F	Max. C
90°	130	115	975	1220	0
90°	130	130	960	1220	50
90°	130	170	945	1250	70
90°	150	200	915	1270	100
90°	150	220	915	1290	150
90°	120	270	900	1300	200
120°	180	130	915	1300	50

ATS50AGS ATS50AGR ATS50AGM

Gate-leaf opening (°)	A	B	E	F	Max. C
90°	200	220	1030	1450	150
90°	200	285	1020	1510	200
120°	200	140	1040	1460	70

Fastening the brackets

Secure the post bracket with plugs and screws.
Fasten in place with screws or weld the bracket to the gate.

 Only use the brackets supplied with the product.

 The holes on the bracket fixing plate allow you to vary the opening angle of the gate leaf.

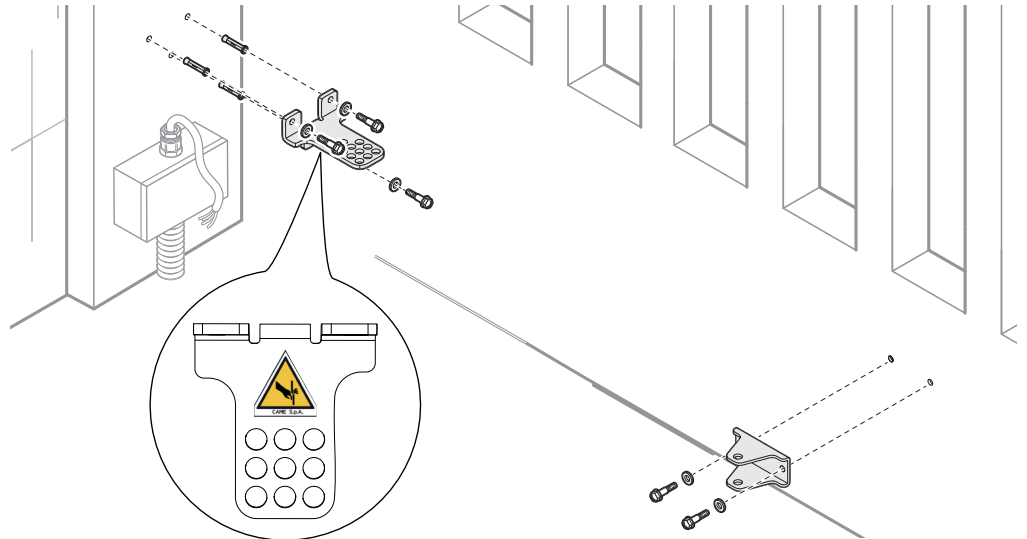
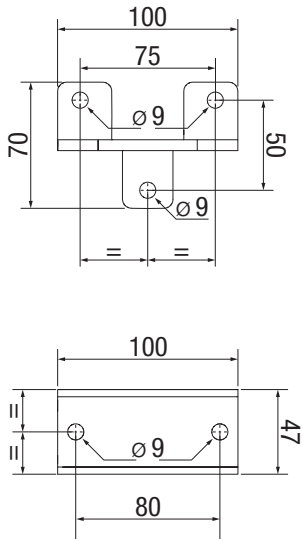

Fastening the gearmotor

 Lubricate all moving parts on the operator.

A The self-locking nut must be loosely tightened so as not to affect the movement of the telescopic arm with the gate bracket.

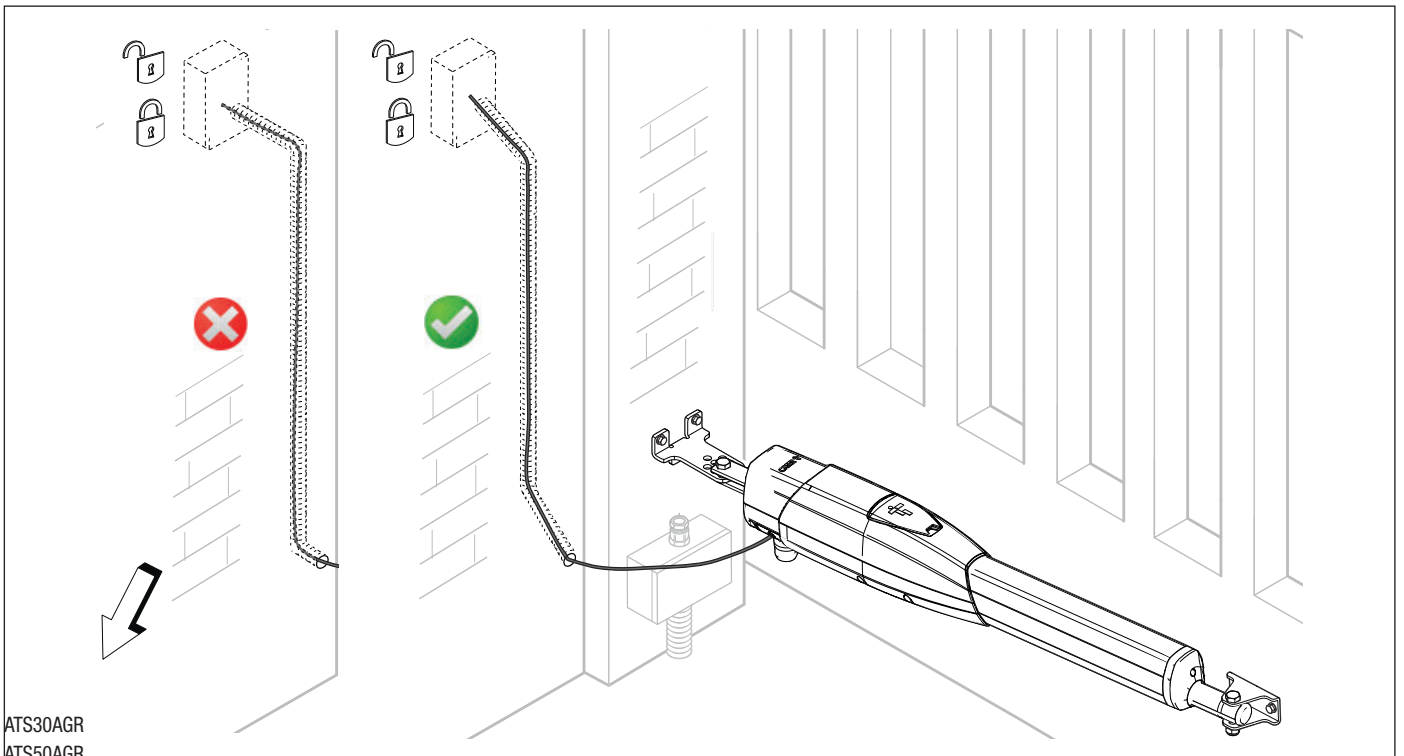
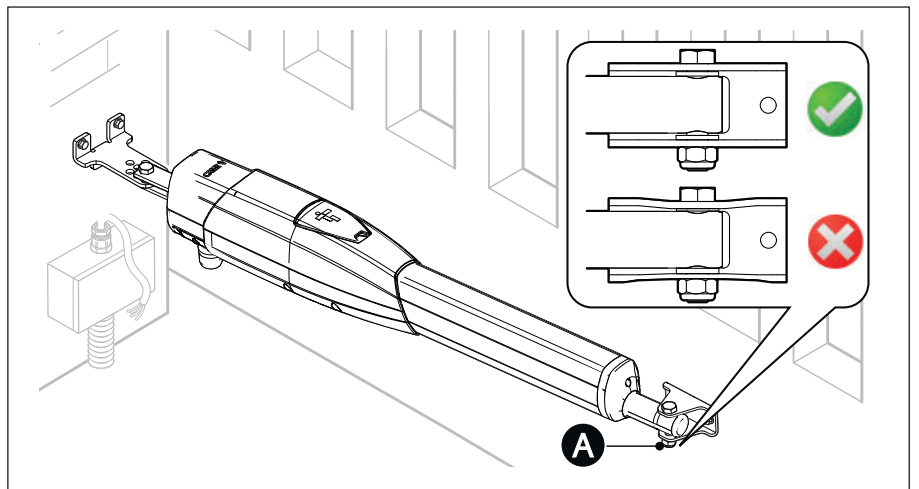
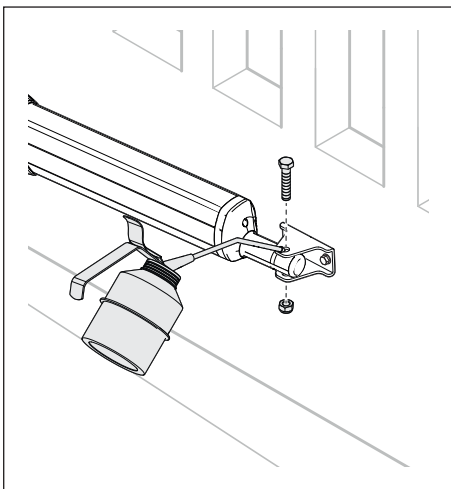
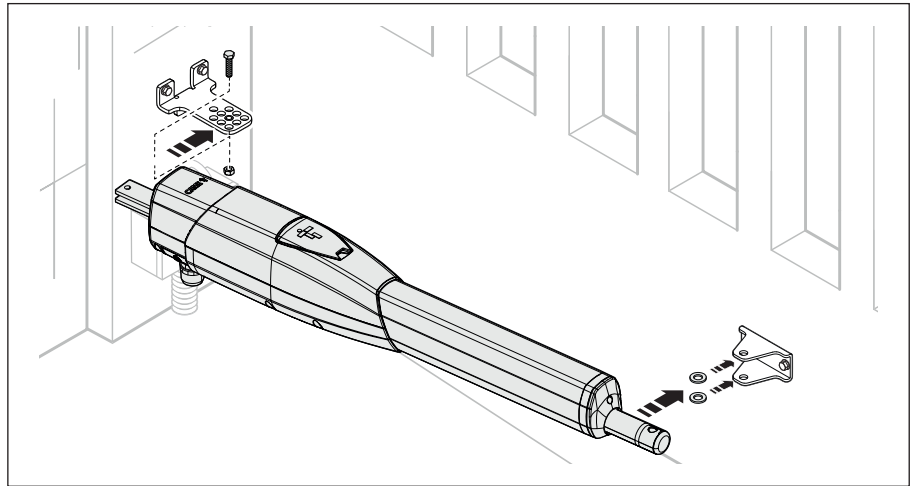
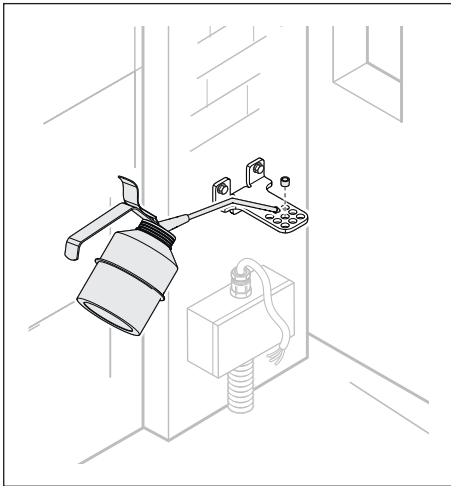

ATS30AGR
ATS50AGR

ELECTRICAL CONNECTIONS

⚠ Before working on the control panel, disconnect the mains power supply and remove the batteries, if any.

📖 Remove the protective cover to access the terminal block.

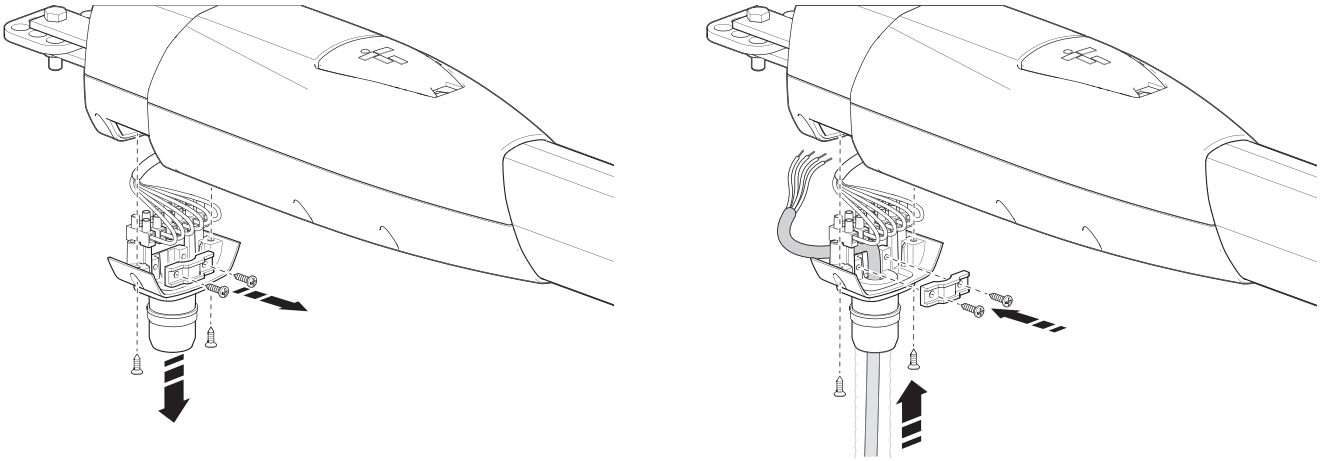

- A** Control panel
- B** Gearmotor delayed while opening
- C** Gearmotor delayed while closing
- D** 230 V AC - 50-60 HZ power supply input
- 1** Yellow/green cable

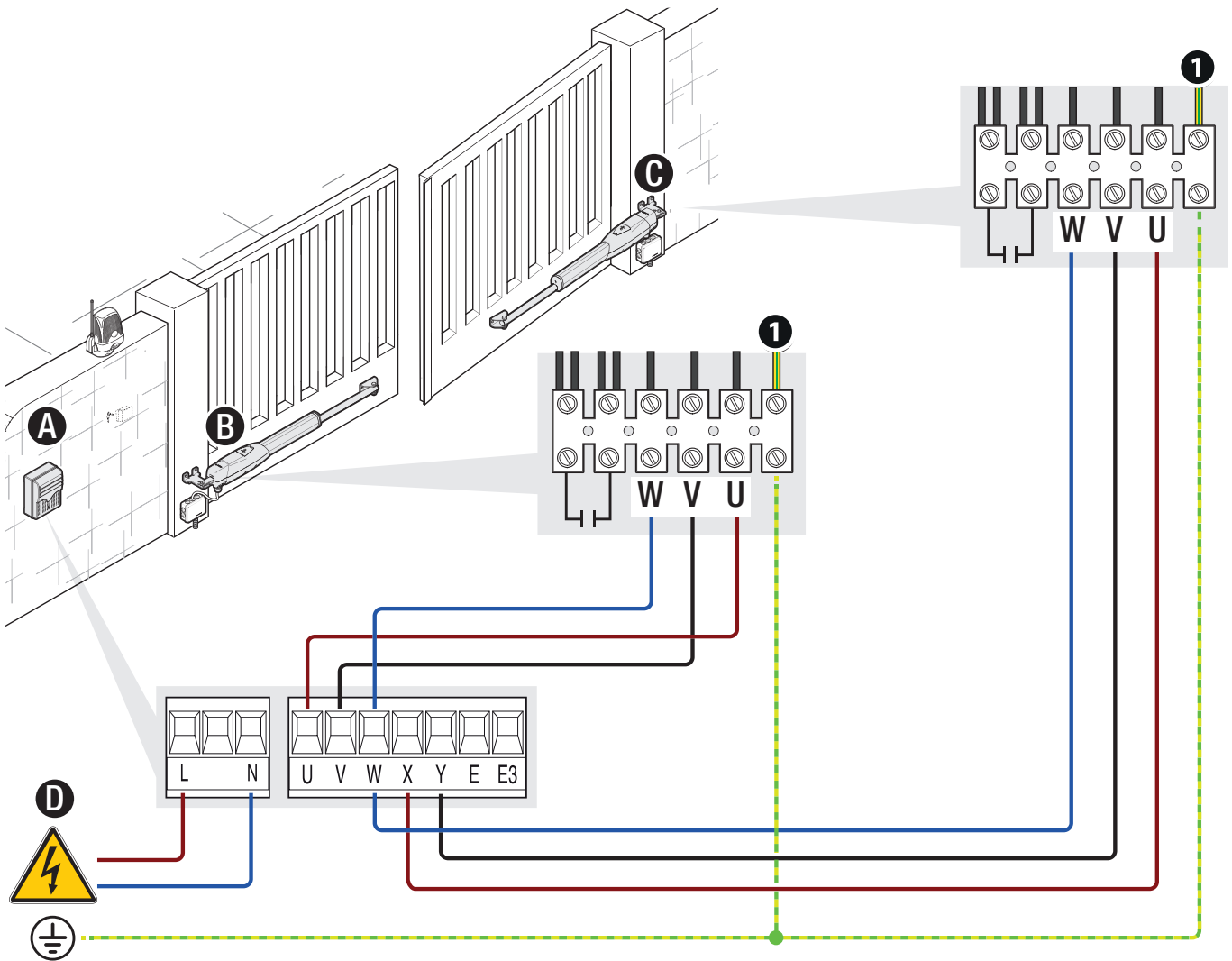

Determining the end-of-travel points with micro limit switches

Where there are no mechanical stops on the ground, the end-of-travel microswitches must be adjusted.

A Rod for determining the opening end-of-travel point

C Rod for determining the closing end-of-travel point

M Micro limit switches

The micro switches are positioned at the far ends of the travel range.

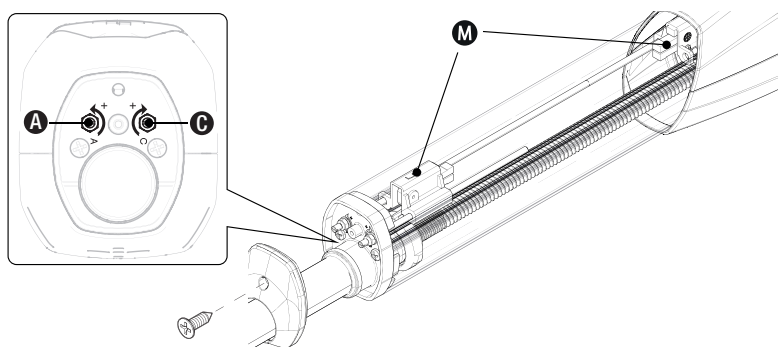

To move the microswitch 10 mm in either direction, turn the rod 12 times.

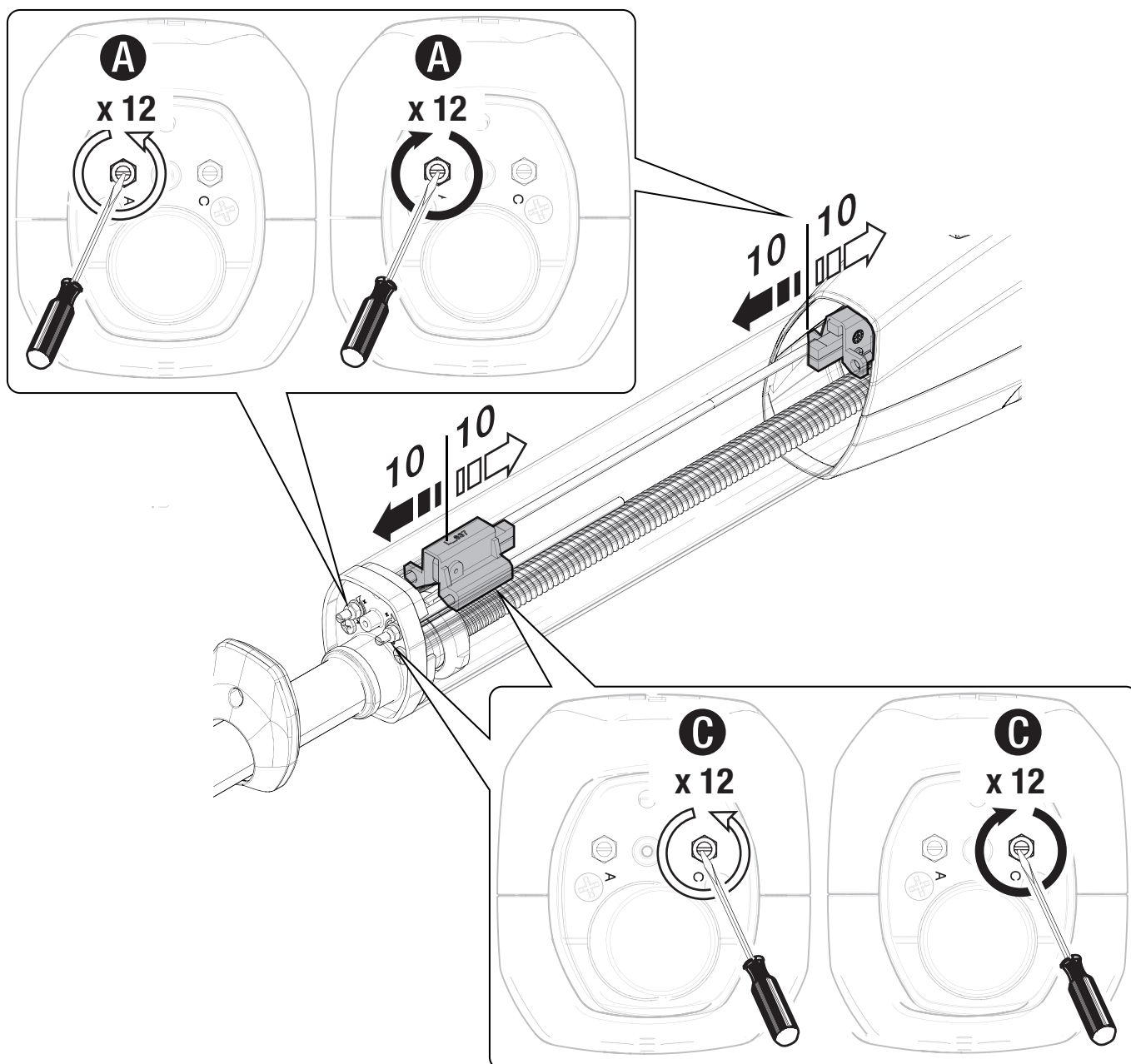

 The travel end point adjustment procedure using a multimeter (tester) is described below. Alternatively, there is a specific tool available for adjusting the end point (code 801XC-0180).

Determining the opening end-of-travel points

 Perform these operations on both gearmotors.

Release the gearmotor.

Manually open the leaf to the desired point.

Remove the terminal board from the motor compartment.

Connect the multimeter, set to check continuity, to the terminals as indicated in the figure below; the multimeter will beep.

Turn the rod  CLOCKWISE to determine the opening travel end point, until the multimeter stops beeping.

 The number of rod turns varies according to how the brackets are fixed. See table overleaf.

 Leave the rod nut loose.

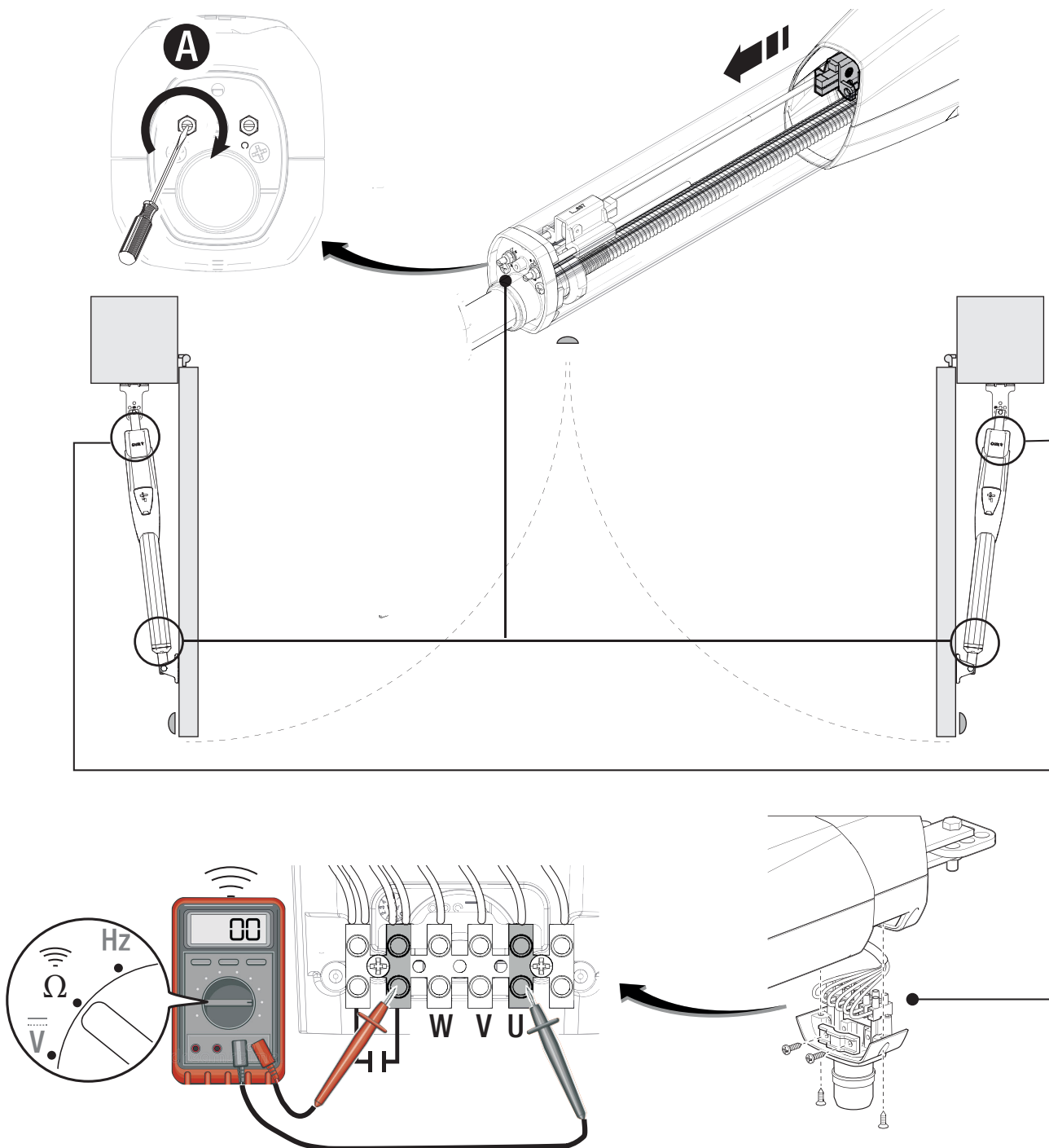

Determining the closing end-of-travel points

 Perform these operations on both gearmotors.

With the gearmotor released, close the gate leaf manually.

Connect the multimeter, set to check continuity, to the terminals as indicated in the figure below; the multimeter will beep.

Turn the rod  ANTICLOCKWISE to determine the closing travel end point, until the multimeter stops beeping.

 The number of rod turns varies according to how the brackets are fixed. See table overleaf.

 Leave the rod nut loose.

Once complete, insert the terminal board in the motor compartment and fix it in place.

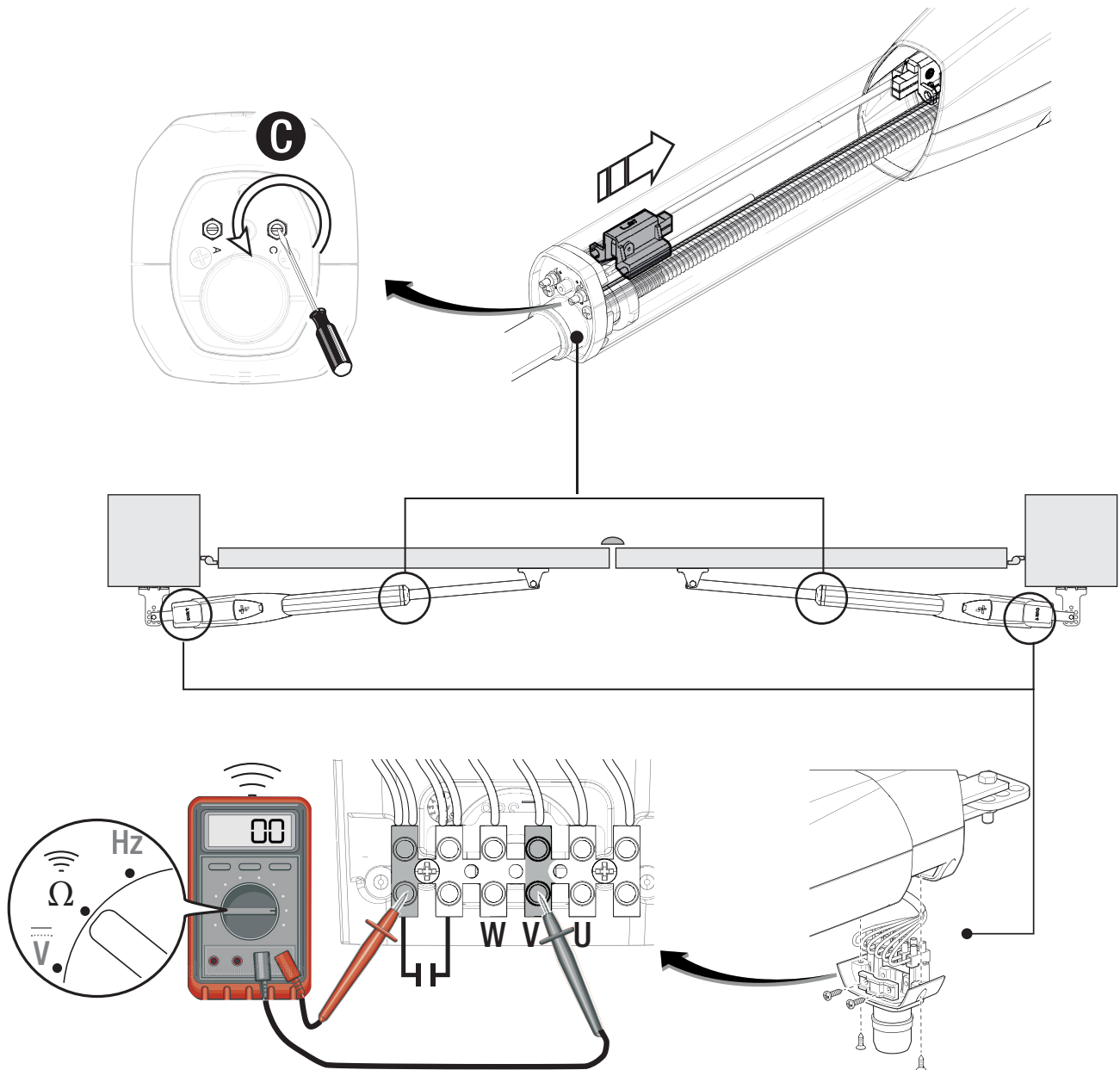

The table below shows the number of rod turns and the direction of rotation for adjusting the limit switch, according to the bracket fixing measurements.

ATS30AGS ATS30AGR ATS30AGM

Gate-leaf opening (°)	A	B	E	F	Max. C	Number of rod turns in a CLOCKWISE direction (adjusting the opening limit switch)	Number of rod turns in an ANTICLOCKWISE direction (adjusting the closing limit switch)
90°	130	115	975	1220	0	~95	~100
90°	130	130	960	1220	50	~75	~100
90°	130	170	945	1250	70	~60	~60
90°	150	200	915	1270	100	~20	~40
90°	150	220	915	1290	150	~20	~10
90°	120	270	900	1300	200	0	0
120°	180	130	915	1300	50	~20	0

ATS50AGS ATS50AGR ATS50AGM

Gate-leaf opening (°)	A	B	E	F	Max. C	Number of rod turns in a CLOCKWISE direction (adjusting the opening limit switch)	Number of rod turns in an ANTICLOCKWISE direction (adjusting the closing limit switch)
90°	200	220	1030	1450	150	~40	~75
90°	200	285	1020	1510	200	~10	0
120°	200	140	1040	1460	70	~40	~60

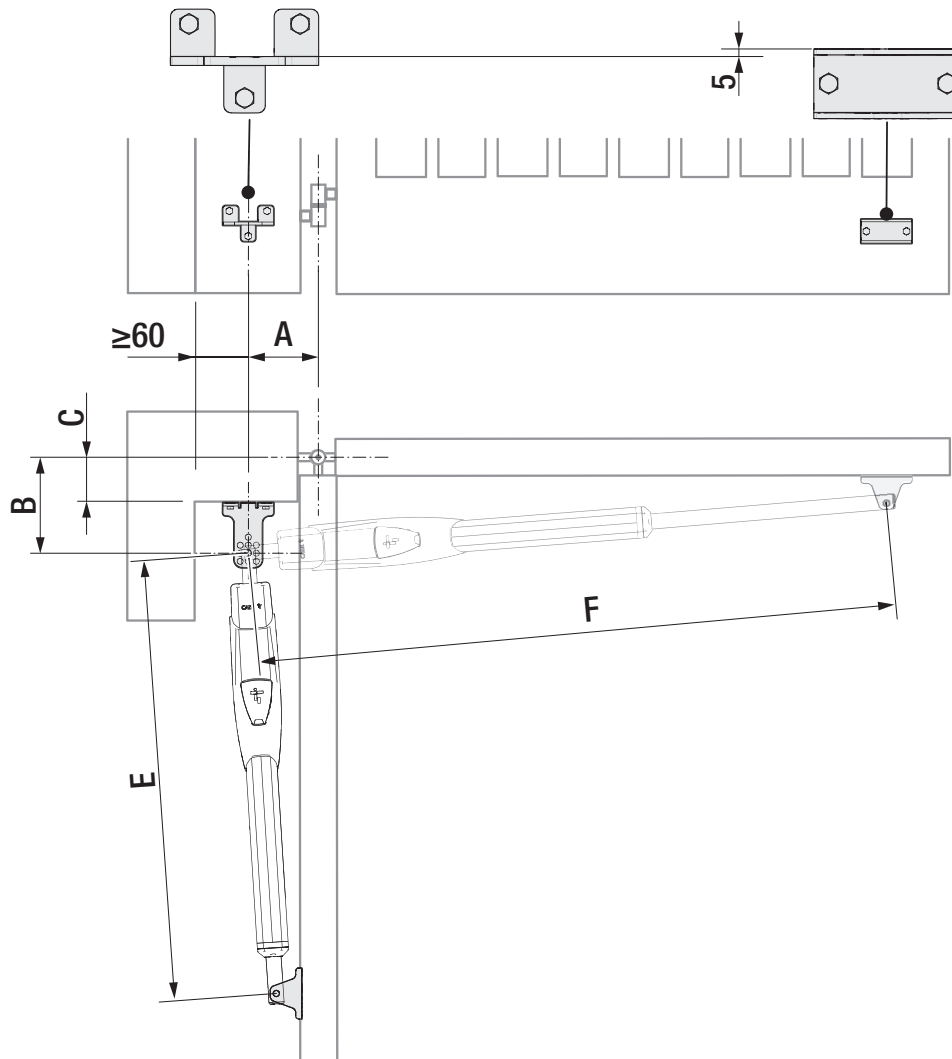

OUTWARDS OPENING

Deciding where to fasten the brackets

⚠ The gate should be closed when taking the measurements for determining where the brackets should be fixed.

Close the gate manually.

Identify the position where the gate bracket will be fixed (at a suitable height from the ground), then the position of the post bracket, respecting the measurements given in the figure below.

A Additional bracket (not included)

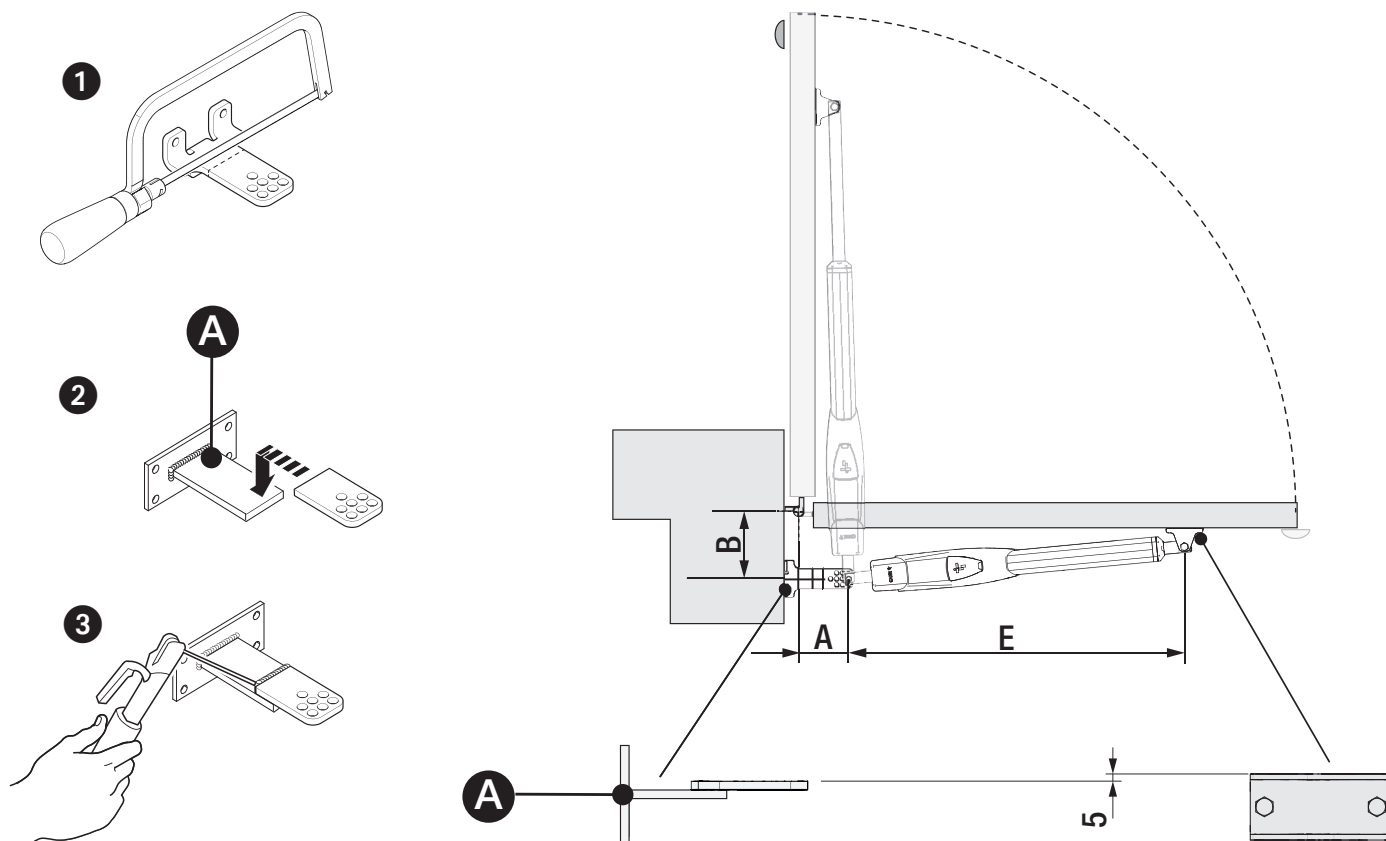

ATS30AGS

ATS30AGR

ATS30AGM

Gate-leaf opening (°)

90°

A

150

B

150

E

960

ATS50AGS

ATS50AGR

ATS50AGM

Gate-leaf opening (°)

90°

A

200

B

200

E

1060

Electrical connections

⚠ Before working on the control panel, disconnect the mains power supply and remove the batteries, if any.

📖 Remove the protective cover to access the terminal block.

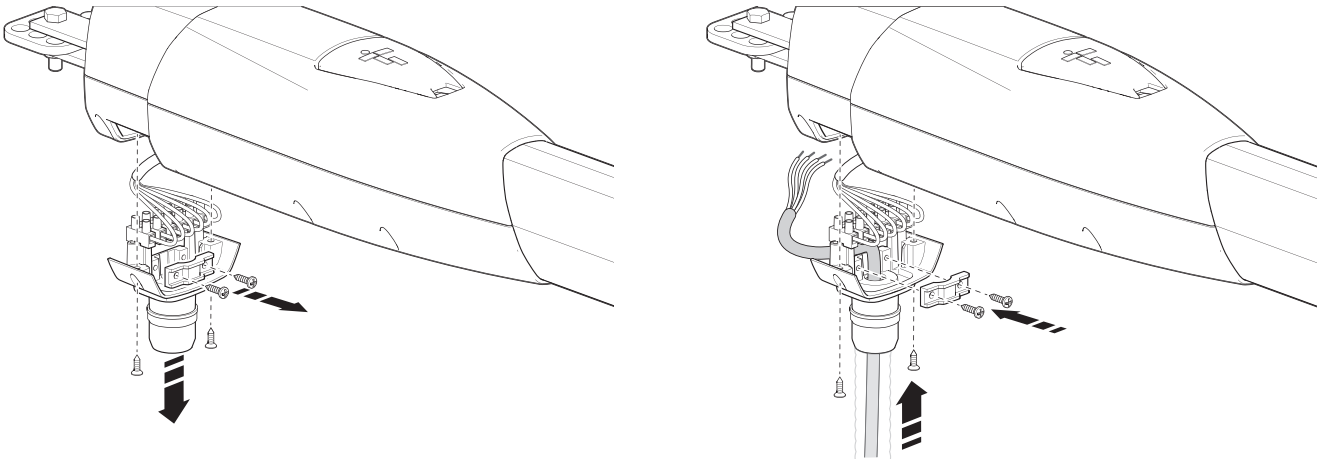

- A** Control panel
- B** Gearmotor delayed while opening
- C** Gearmotor delayed while closing
- D** 230 V AC - 50-60 HZ power supply input
- 1** Yellow/green cable

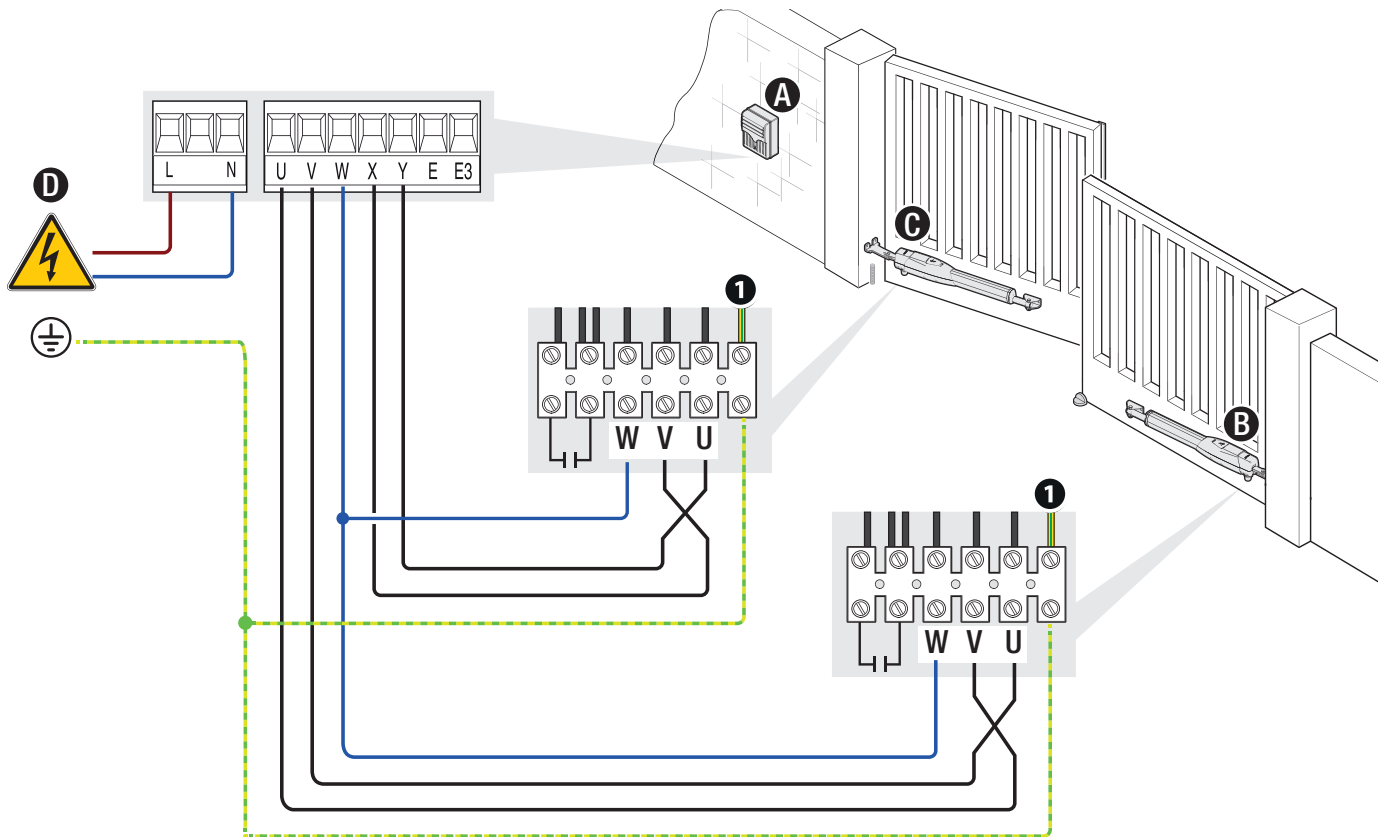

Determining the end-of-travel points with micro limit switches

Where there are no mechanical stops on the ground, the end-of-travel microswitches must be adjusted.

- A** Rod for determining the closing end-of-travel point
- C** Rod for determining the opening end-of-travel point
- M** Micro limit switches

The micro switches are positioned at the far ends of the travel range.

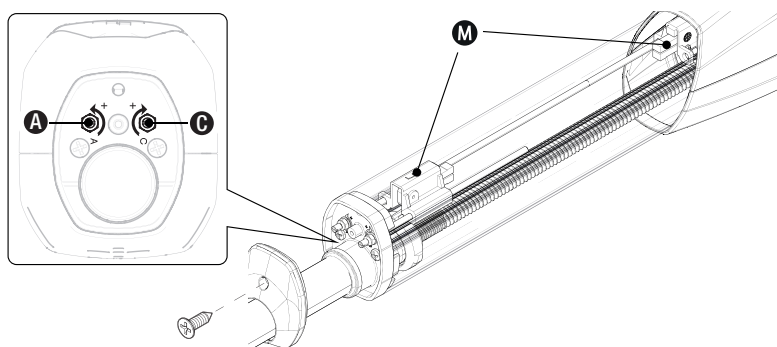

To move the microswitch 10 mm in either direction, turn the rod 12 times.

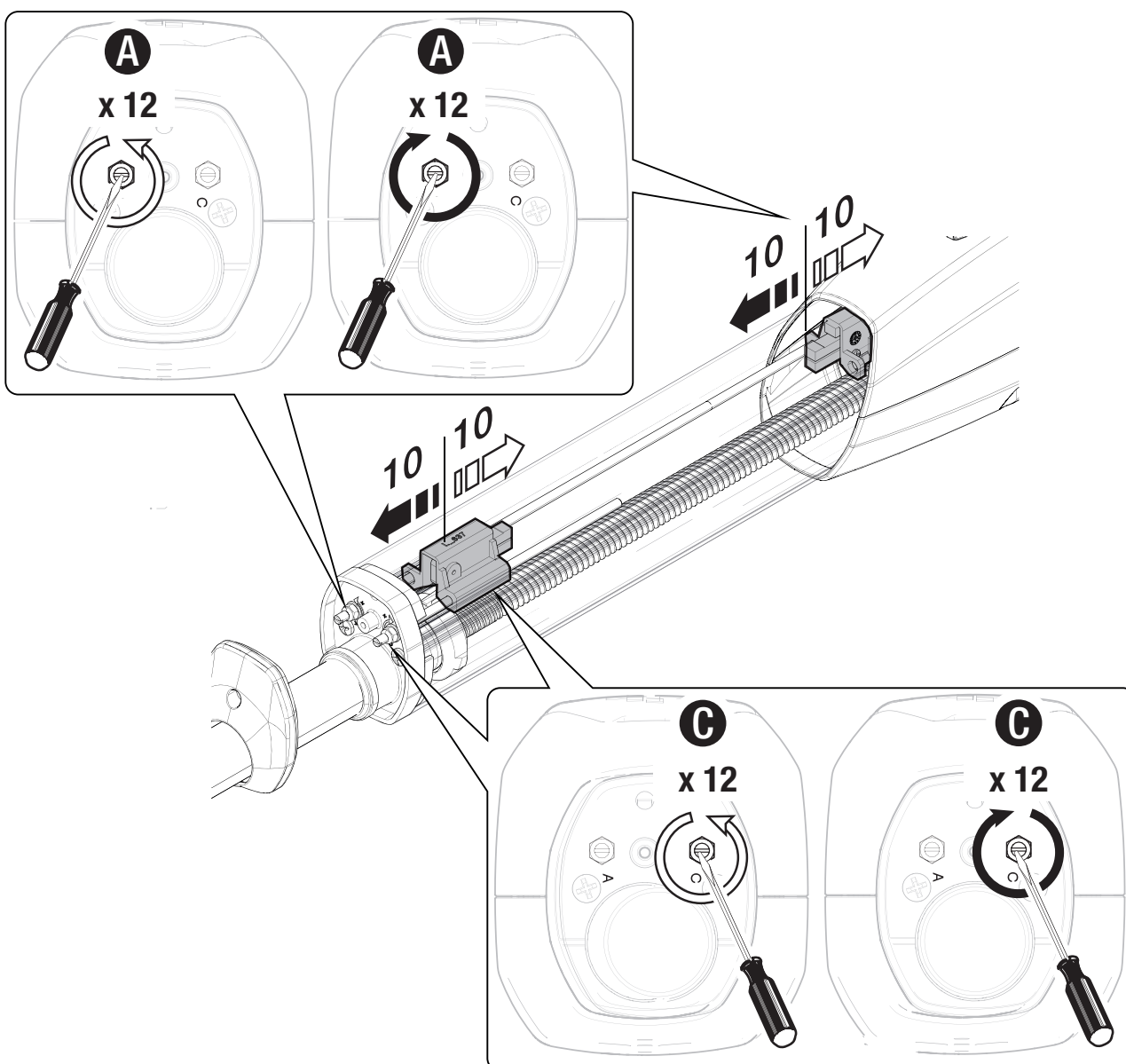

 The travel end point adjustment procedure using a multimeter (tester) is described below. Alternatively, there is a specific tool available for adjusting the end point (code 801XC-0180).

Determining the opening end-of-travel points

 Perform these operations on both gearmotors.

Release the gearmotor.

Manually open the leaf to the desired point.

Remove the terminal board from the motor compartment.

Connect the multimeter, set to check continuity, to the terminals as indicated in the figure below; the multimeter will beep.

Turn the rod  ANTICLOCKWISE to determine the opening travel end point, until the multimeter stops beeping.

 The number of rod turns varies according to how the brackets are fixed. See table overleaf.

 Leave the nut loose on the threaded rod.

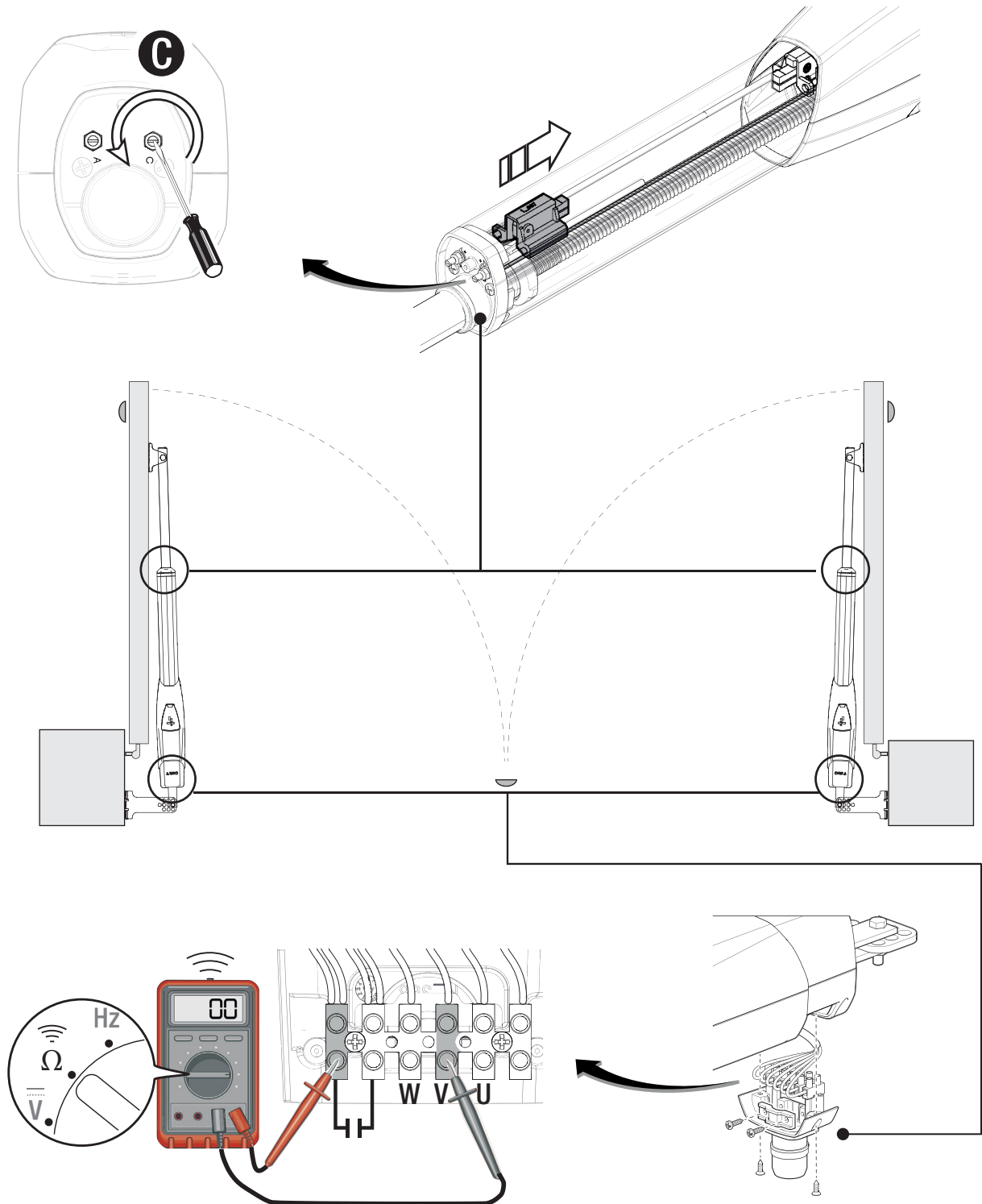

Determining the closing end-of-travel points

📖 Perform these operations on both gearmotors.

With the gearmotor released, close the gate leaf manually.

Connect the multimeter, set to check continuity, to the terminals as indicated in the figure below; the multimeter will beep.

Turn the rod ⚙️ **CLOCKWISE** to determine the closing travel end point, until the multimeter stops beeping.

📖 The number of rod turns varies according to how the brackets are fixed. See table overleaf.

📖 Leave the nut loose on the threaded rod.

Once complete, insert the terminal board in the motor compartment and fix it in place.

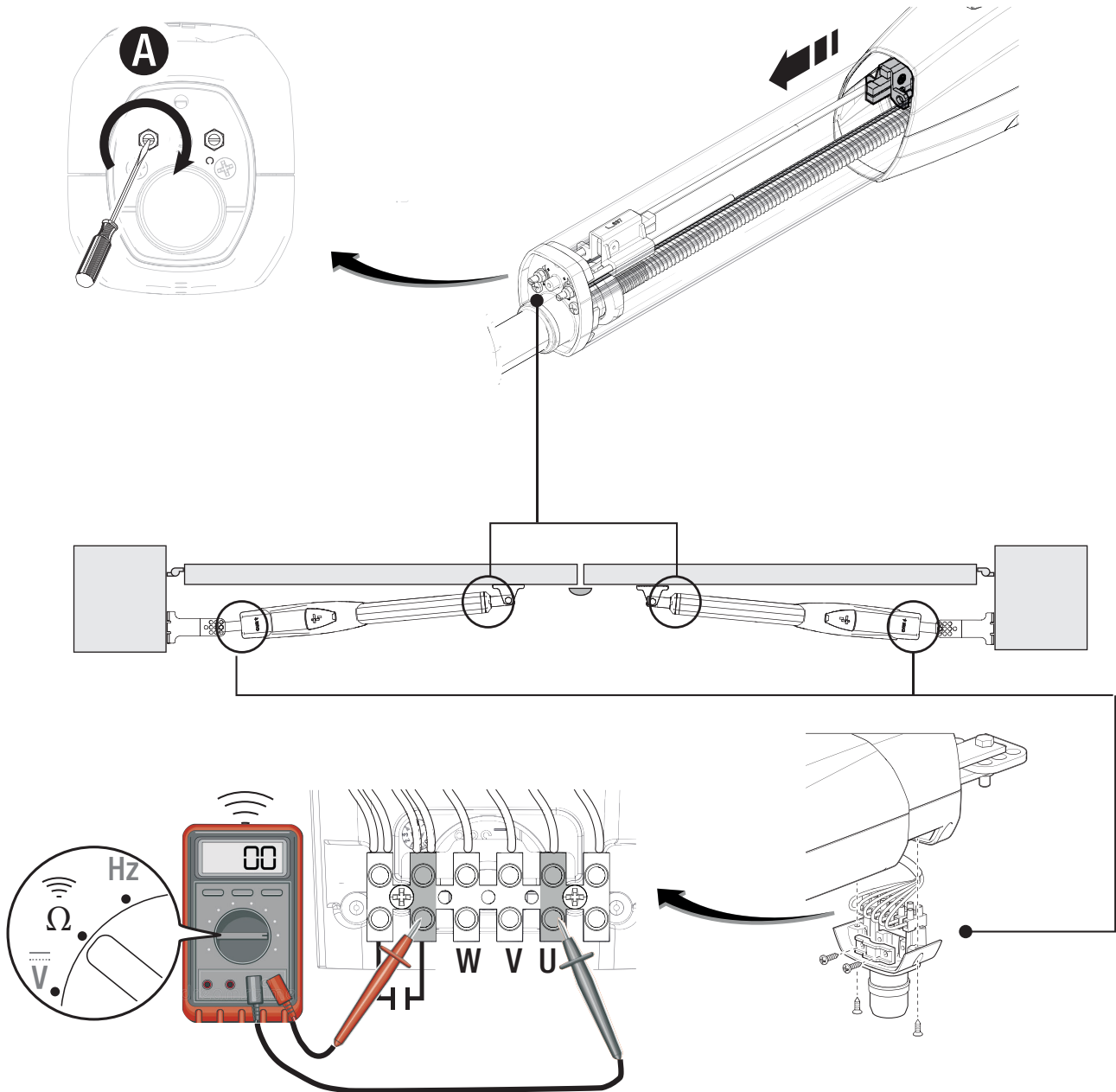

ATS30AGS ATS30AGR ATS30AGM

Gate-leaf opening (°)	A	B	E	Number of rod turns in an ANTICLOCKWISE direction (adjusting the opening limit switch)	Number of rod turns in a CLOCKWISE direction (adjusting the closing limit switch)
90°	150	150	960	~75	~50

ATS50AGS ATS50AGR ATS50AGM

Gate-leaf opening (°)	A	B	E	Number of rod turns in an ANTICLOCKWISE direction (adjusting the opening limit switch)	Number of rod turns in a CLOCKWISE direction (adjusting the closing limit switch)
90°	200	200	1060	~60	~60

FINAL OPERATIONS

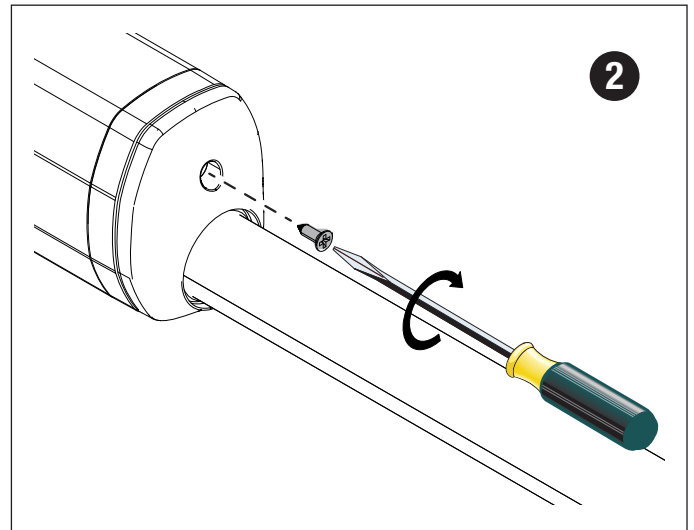
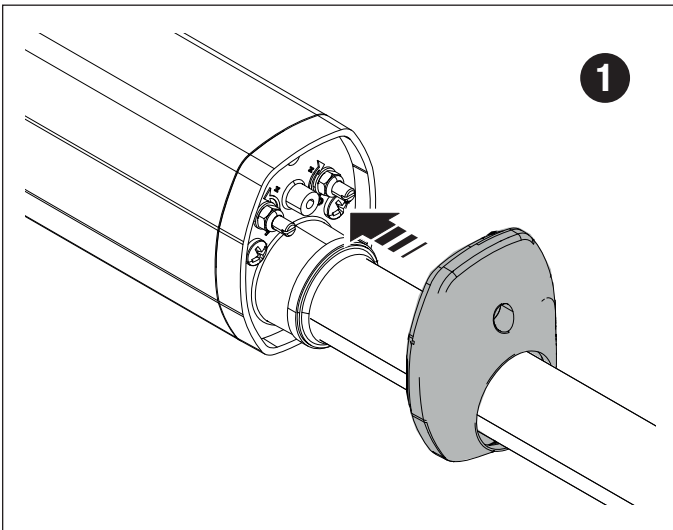

MCBF		
Models	ATS30AGS-ATS30AGR-ATS30AGM	ATS50AGS-ATS50AGR-ATS50AGM
2 m - 800 kg	120000	-
2.5 m - 600 kg	110000	-
3 m - 400 kg	100000	-
2 m - 1000 kg	-	120000
2.5 m - 800 kg	-	110000
3 m - 600 kg	-	100000
4 m - 500 kg	-	85000
5 m - 400 kg	-	70000
Full leaf	-15%	-15%
Installation in windy area	-15%	-15%
Full leaf installed in windy area	-30%	-30%

The percentages indicate how much the number of cycles should be reduced in relation to the type and number of accessories installed.

Before carrying out any cleaning or maintenance, or replacing any parts, disconnect the device from the power supply.

This document informs the installer of the checks that must be carried out during maintenance.

If the system is not used for long periods of time, e.g. for installations at sites with seasonal closures, disconnect the power supply. When the power supply is reconnected, check the system is working correctly.

For information on correct installation and adjustments, please see the product installation manual.

For information on choosing products and accessories, please see our product catalogue.

Every 20,000 cycles – or at least every 6 months of use – the following maintenance must be performed.

Perform a general and complete check of the tightness of the nuts and bolts.

Grease all of the moving mechanical parts.

Check the warning and safety devices are working properly.

Check for any wear on the moving mechanical parts and check that they are working properly.

Check the release mechanism is working efficiently by performing a manoeuvre with the leaf free. The gate leaf must not be obstructed.

Check the cables are intact and connected correctly.

Open the release hatch and clean any dirt.

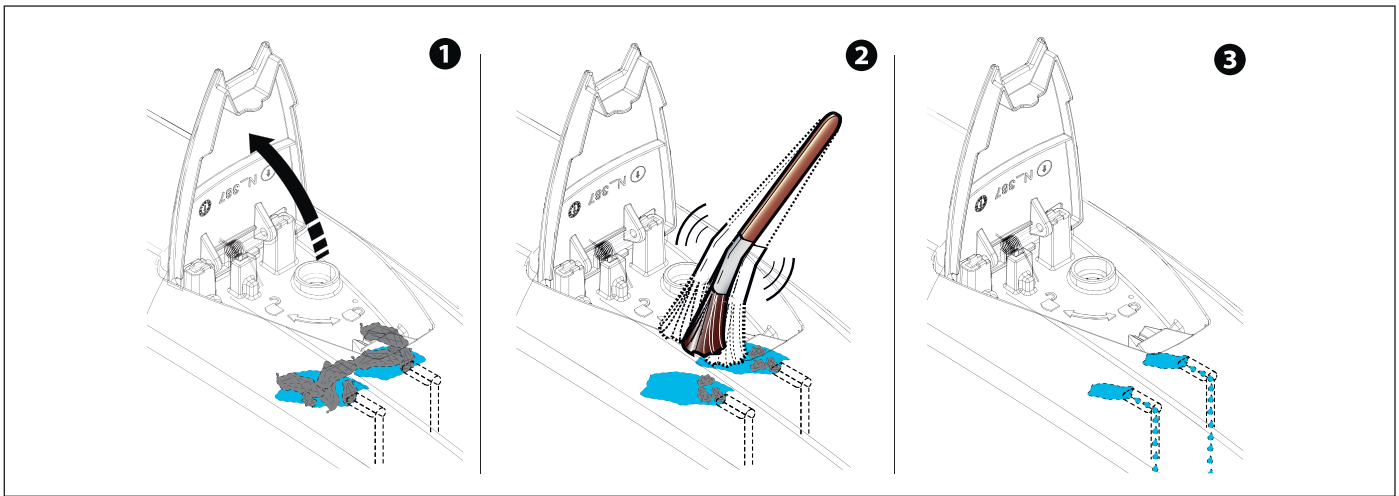

Grease the scraper ring on the end cap using EP2 grease.

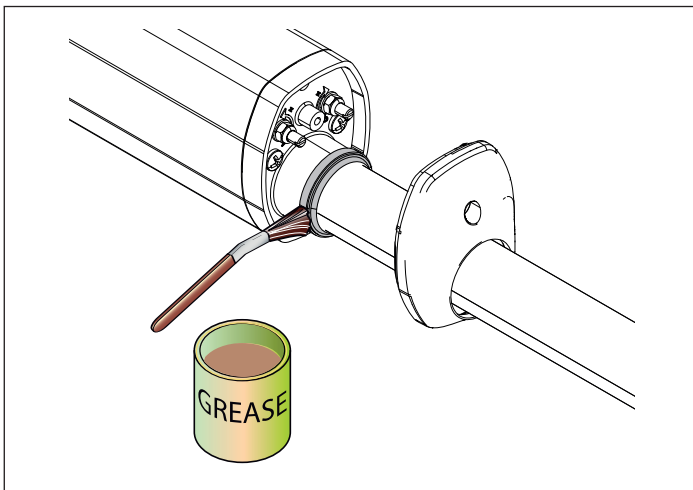



CAME.COM

CAME S.P.A.

Via Martiri della Libertà, 15
31030 Dosson di Casier
Treviso – Italy
Tel. (+39) 0422 4940
Fax (+39) 0422 4941