

CAME

119DU80EN

OPERATOR FOR SWING GATES



Installation manual

A18230



CAUTION!

important personal safety instructions: READ CAREFULLY!



Premise

- Employ this product only for the use for which it was expressly made. Any other use is dangerous. CAME S.p.A. is not liable for any damage caused by improper, wrongful and unreasonable use • Keep these warnings together with the installation and operation manuals that come with the operator.

Before installing

(checking what's there: if your evaluation is negative, do not proceed before having complied with all safety requirements)

- Check that the automated parts are in good mechanical order, that the operator is level and aligned, and that it opens and closes properly. Make sure you have suitable mechanical stops • If the operator is to be installed at a height of over 2.5 m from the ground or other access level, make sure you have any necessary protections and/or warnings in place • If any pedestrian openings are fitted into the operator, there must also be a system to block their opening while they are moving • Make sure that the opening automated door or gate cannot entrap people against the fixed parts of the operator • Do not install the operator upside down or onto elements that could yield and bend. If necessary, add suitable reinforcements to the anchoring points • Do not install door or gate leaves on tilted surfaces • Make sure any sprinkler systems cannot wet the operator from the ground up • Make sure the temperature range shown on the product literature is suitable to the climate where it will be installed • Follow all instructions as improper installation may result in serious bodily injury • It is important to follow these instructions for the safety of people. Keep these instructions.

Installing

- Suitably section off and demarcate the entire installation site to prevent unauthorized persons from entering the area, especially minors and children • Be careful when handling operators that weigh over 20 kg. If need be, use proper safety hoisting equipment • All opening commands (that is, buttons, key switches, magnetic readers, and so on) must be installed at least 1.85 m from the perimeter of the gate's working area, or where they cannot be reached from outside the gate. Also, any direct commands (buttons, touch panels, and so on) must be installed at least 1.5 m from the ground and must not be reachable by unauthorized persons • All maintained action commands, must be fitted in places from which the moving gate leaves and transit and driving areas are visible • Apply, if missing, a permanent sign showing the position of the release device • Before delivering to the users, make sure the system is EN 12453 standard compliant (regarding impact forces), and also make sure the system has been properly adjusted and that any safety, protection and manual release devices are working properly • Apply Warning Signs (such as the gate's plate) where necessary and in a visible place

Special user-instructions and recommendations

- Keep gate operation areas clean and free of any obstructions. Make sure that the photocells are free of any overgrown vegetation and that the operator's area of operation is free of any obstructions • Do not allow children to play with fixed commands, or to loiter in the gate's maneuvering area. Keep any remote control transmitters or any other command device away from children, to prevent the operator from being accidentally activated. • The apparatus may be used by children of eight years and above and by physically, mentally and sensorially challenged people, or even ones without any experience, provided this happens under close supervision or once they have been properly instructed to use the apparatus safely and about the potential hazards involved. Children must not play with the apparatus. Cleaning and maintenance by users must not be done by children, unless properly supervised • Frequently check the system for any malfunctions or signs of wear and tear or damage to the moving structures, to the component parts, all anchoring points, including cables and any accessible connections. Keep any hinges, moving joints and slide rails properly lubricated • Perform functional checks on the photocells and sensitive safety edges, every six months. To check whether the photocells are working, wave an object in front of them while the gate is closing; if the operator inverts its direction of travel or suddenly stops, the photocells are working properly. This is the only maintenance operation to do with the power on. Constantly clean the photocells' glass covers using a slightly water-moistened cloth; do not use any solvents or other chemical products that may ruin

the devices • If repairs or modifications are required to the system, release the operator and do not use it until safety conditions have been restored • Cut off the power supply before releasing the operator for manual openings and before any other operation, to prevent potentially hazardous situations. Read the instructions • If the power supply cable is damaged, it must be replaced by the manufacturer or authorized technical assistance service, or in any case, by similarly qualified persons, to prevent any risk • It is FORBIDDEN for users to perform any OPERATIONS THAT ARE NOT EXPRESSLY REQUIRED OF THEM AND WHICH ARE NOT LISTED in the manuals. For any repairs, modifications and adjustments and for extraordinary maintenance, CALL TECHNICAL ASSISTANCE • Log the job and checks into the periodic maintenance log.

Additional special recommendations for everyone

- Keep away from hinges and mechanical moving parts • Do not enter the operator's area of operation when it is moving • Do not counter the operator's movement as this could result in dangerous situations • Always pay special attention to any dangerous points, which have to be labeled with specific pictograms and/or black and yellow stripes • While using a selector switch or a command in maintained actions, keep checking that there are no persons within the operating range of any moving parts, until the command is released • The gate may move at any time and without warning • Always cut off the power supply before performing any maintenance or cleaning.

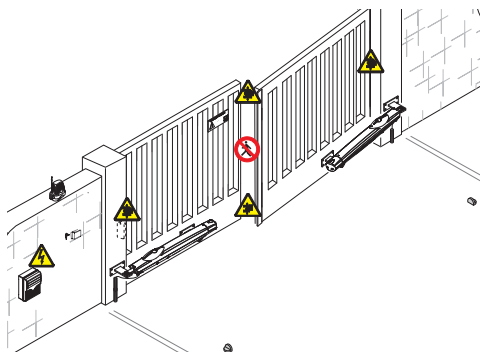

Danger of foot crushing



Danger of hand crushing





Danger - live parts



No transit during the manoeuvre

KEY

-  This symbol indicates parts to read carefully.
-  This symbol indicates parts about safety.
-  This symbol tells you what to say to the end users.

REGULATORY REFERENCES

Came Cancelli Automatici is a company with an ISO 9001-certified company quality management system and an ISO 14001-certified environmental management system.
The product in question complies with the regulations referred to in the declaration of conformity.

DESCRIPTION

The gearmotor consists of two half-shells made of cast aluminium, inside which is located the gearmotor - with electric lock - and a epicyclic reduction gear system with worm screw.

Dimensions (mm)

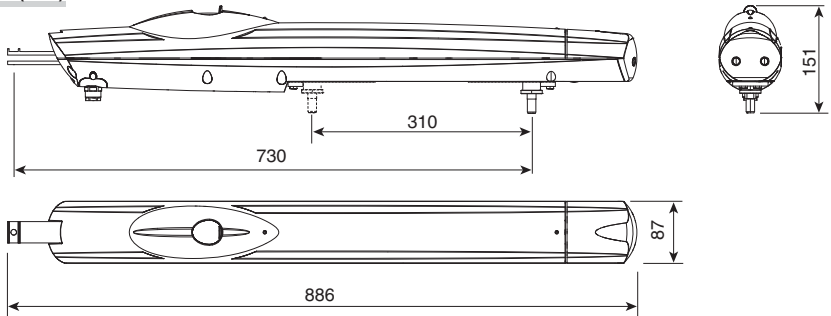

Packing list

1. 1 x gearmotor
2. 1 x additional bracket
3. 1 x pillar bracket
4. 1 x slotted bracket to be welded
5. 1 x gate bracket
6. 1 x installation manual
7. 1 x joint bushing
8. 1 x support washer
9. 1 x medium UNI5588 M8 nut
10. 1 x UNI5737 8X35 hex screw
11. 1 x pin spacer
12. 1 x UNI7474 M12 self-locking nut
13. 2 x release keys

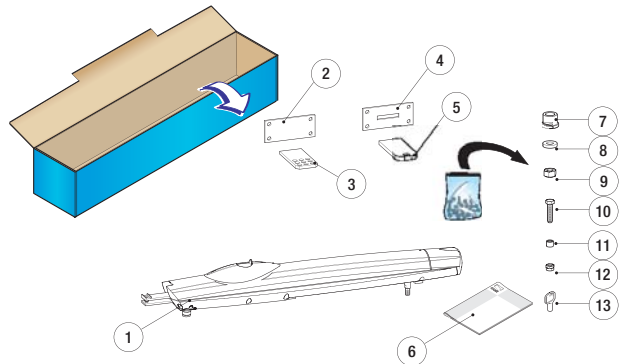

Intended use

The A18230 gearmotor has been designed and built by CAME S.p.A. in compliance with current safety standards to motorise swing gates for residential or condominium use.

 Any installation and operation that differs from what is set out in this manual is prohibited.

Limitations of use

We suggest you always fit an electrolock onto swing gates for a more reliable closure.

Type	A18230		
Max. leaf width (m)	1	1,7	2,2
Max. leaf weight (kg)	250	225	200

Technical data

Type	A18230
IP rating	44
Power supply (V - 50/60 Hz)	230 AC
Motor power supply (V - 50/60 Hz)	230 AC
Power draw (A)	1.2 max.
Power (W)	80
Thrust (N)	400 - 2000
Opening time to 90° (sec)	19
Duty cycle	50
Operating temperature (°C)	-20 - +55
Transmission ratio (i)	1/36
Weight (kg)	7,5

Description of the components

1. Gearmotor
2. Pillar bracket
3. Gate bracket
4. Screw, bushing and nut for joint
5. Nut and washer for gate bracket
6. Pin spacer

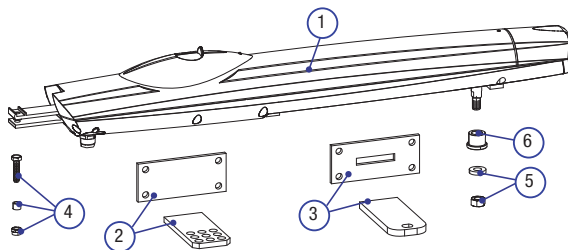

Example of a system

1. Gearmotor
2. Control panel
3. Antenna
4. Flashing light
5. Selector
6. Photocells
7. Inspection chamber
8. Mechanical stops

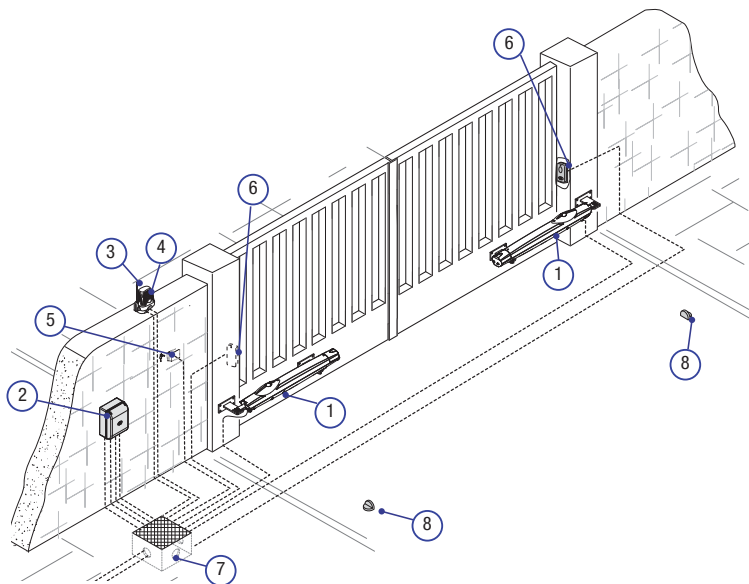

GENERAL INSTALLATION INSTRUCTIONS

△ Installation must be carried out by qualified and experienced personnel in compliance with applicable regulations.

Preliminary checks

△ Before starting installation:

- Provide a suitable single-pole disconnection device, with a maximum of 3 mm between the contacts, to disconnect the power supply;
- Prepare suitable piping and ducts for routing the electrical cables, ensuring protection against mechanical damage;
- ⚠ Make sure that any connections within the container (made to ensure the continuity of the protection circuit) are fitted with additional insulation compared to the other internal conductor parts;
- Make sure the gate structure is sturdy enough, that the hinges are in proper working order and that there is no friction between the moving and fixed parts;
- Make sure there are opening and closing mechanical stops.

Types of cables and minimum thicknesses

Connection	Cable type	Cable length 1 < 10 m	Cable length 10 < 20 m	Cable length 20 < 30 m
Board power supply 230 VAC	FROR CEI 20-22 IEC EN 50267-2-1	3G x 1.5 mm ²	3G x 2.5 mm ²	3G x 2.5 mm ²
230 V AC motor power supply		4G x 1.5 mm ²	4G x 1.5 mm ²	4G x 2.5 mm ²
Flashing light		2 x 0.5 mm ²	2 x 1 mm ²	2 x 1.5 mm ²
Photocell transmitters		2 x 0.5 mm ²	2 x 0.5 mm ²	2 x 0.5 mm ²
Photocell receivers		4 x 0.5 mm ²	4 x 0.5 mm ²	4 x 0.5 mm ²
Control and safety devices		2 x 0.5 mm ²	2 x 0.5 mm ²	2 x 0.5 mm ²
Antenna	RG58	max. 10 m		

N.B.: If the cables differ in length compared to what is shown in the table, the cable cross-section is determined according to the actual current draw of the devices connected and according to the provisions of the IEC EN 60204-1 standard.

For connections that require several, sequential loads, the sizes given on the table must be re-evaluated based on actual power draw and distances. When connecting products that are not specified in this manual, please refer to the documentation provided with said products.

Tools and materials

Make sure you have all the tools and materials you will need for the installation at hand to work in total safety and compliance with current standards and regulations. The figure shows some examples of installer's tools.

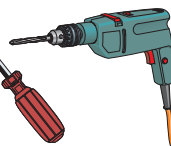
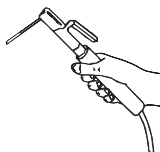

INSTALLATION

△ The following illustrations are only examples, given that the space for securing the operator and accessories varies depending on the overall dimensions. The installation technician is responsible for choosing the most suitable solution.

Installing corrugated tubes

Set up corrugated tubes for the connections coming from the junction box.

N.B. the number of tubes depends on the type of system installed and any accessories.

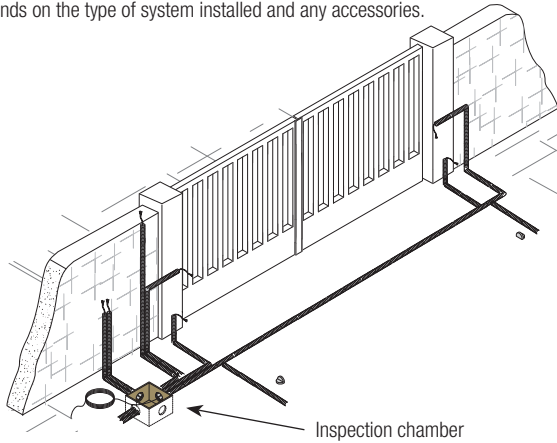

Securing the brackets

△ Caution: determine the fixing point for the gate bracket and calculate the fixing point of the pillar bracket, respecting the values shown in the drawings and table.

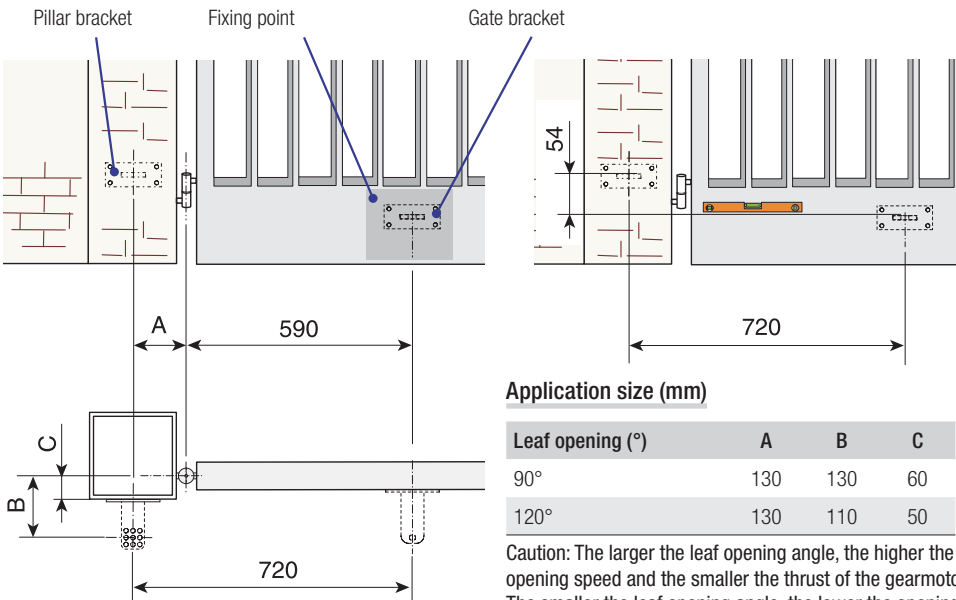

Caution: The larger the leaf opening angle, the higher the opening speed and the smaller the thrust of the gearmotor. The smaller the leaf opening angle, the lower the opening speed and the greater the thrust of the gearmotor.

Weld the two sides of the pillar bracket and secure it with using suitable screws and dowels.

If the pillar is made of metal, weld the bracket to the pillar.

N.B. the holes on the pillar bracket allow further variation of the leaf opening angle.

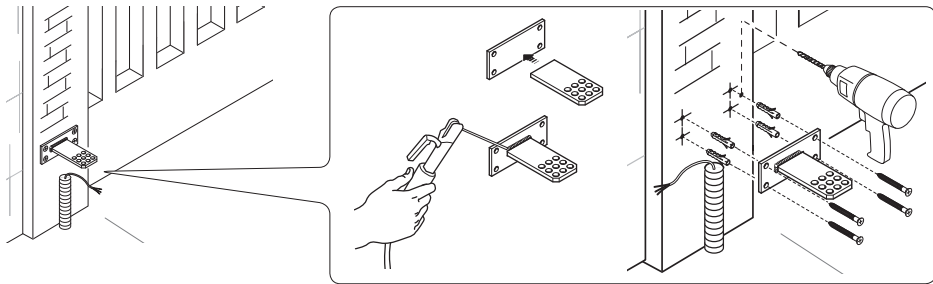

Weld the gate bracket on the leaf.

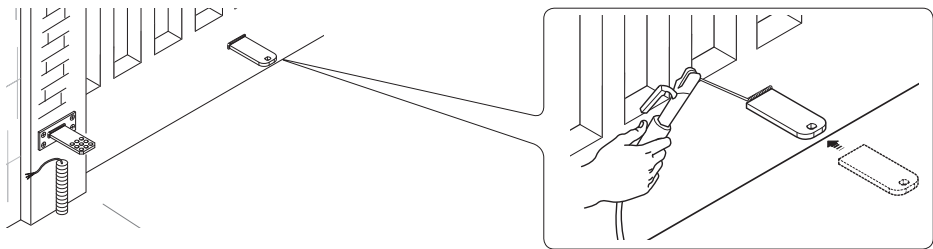

If the gate is not made of metal, weld the gate bracket to the slotted bracket and secure it to the leaf using suitable screws.

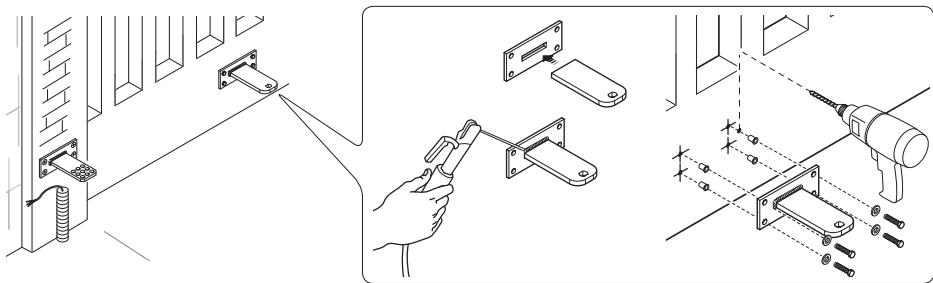

Manual release of the gearmotor

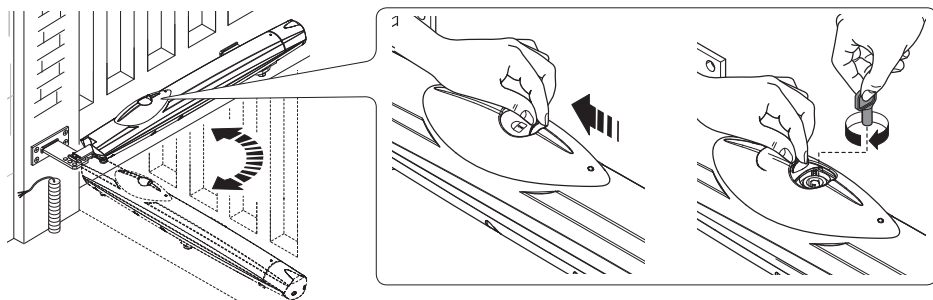

Securing the gearmotor

Lubricate the bushing and insert it into one of the holes on the pillar bracket.

Secure the joint to the pillar bracket with the M8x35 screw and the UNI7474 M8 nut.

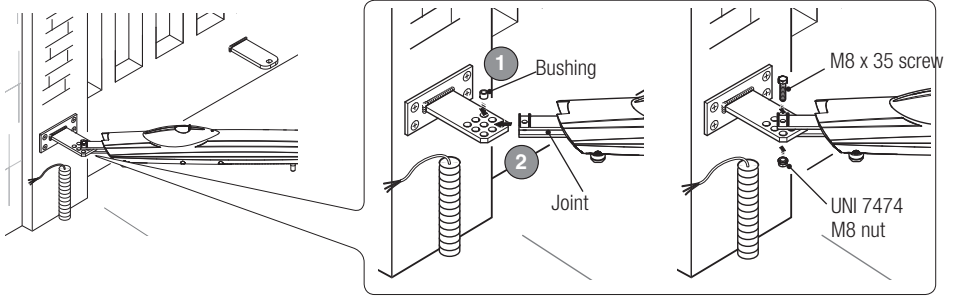

Insert the bushing into the pin.

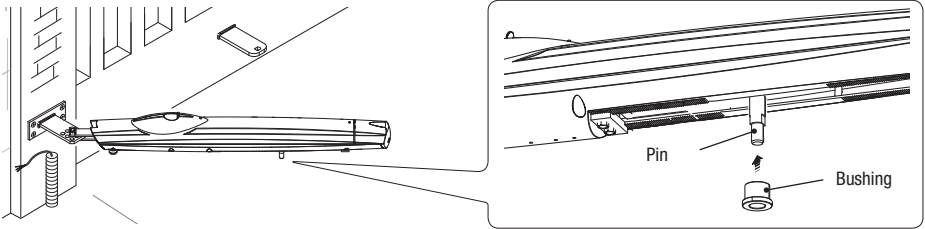

Open the leaf and insert the pin correctly into the slotted hole in the gate bracket **1**.

Or:
Release the gearmotor (see the 'Releasing the gearmotor' paragraph), remove the upper half-shell and move the pin using a screwdriver so it coincides correctly with the slotted hole on the gate bracket **2**.

Secure the pin using the washer and nut provided.

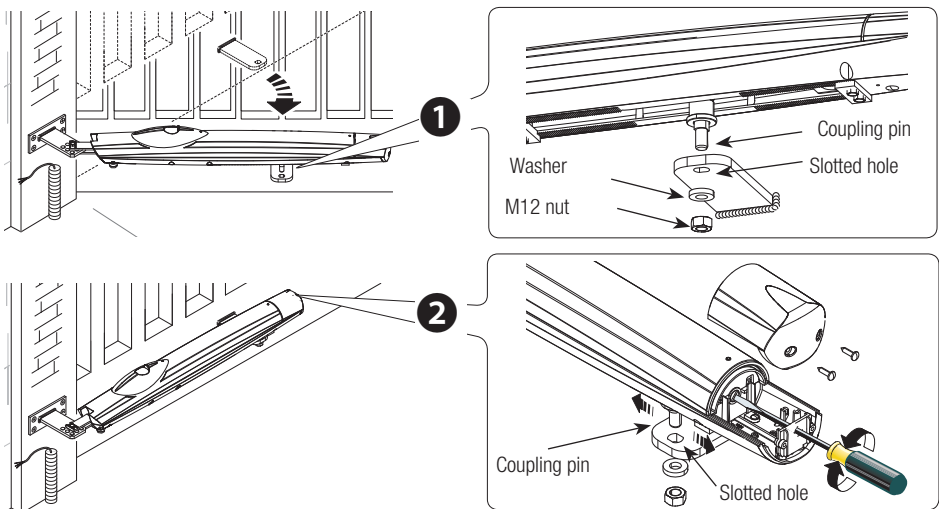

Determining the end run points

During opening.

Open the leaf fully and position the mechanical opening stop at the end of its run with the pin.
Secure the mechanical stop

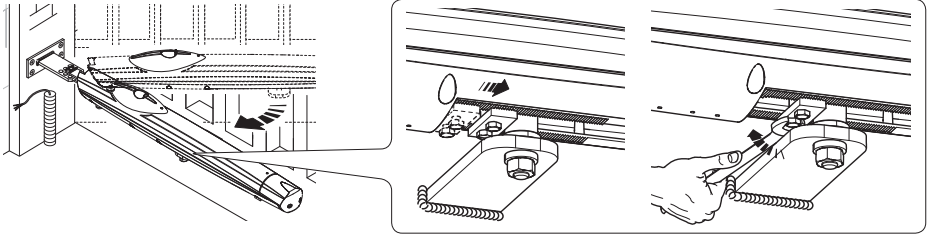

During closing.

Open the leaf fully and position the mechanical closing stop at the end of its run with the pin.
Secure the mechanical stop.

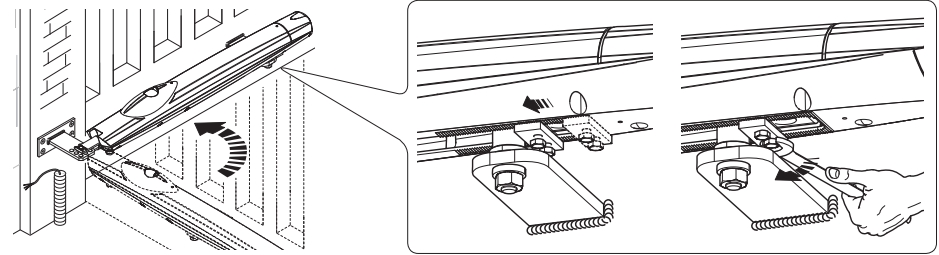

Connecting to the control panel

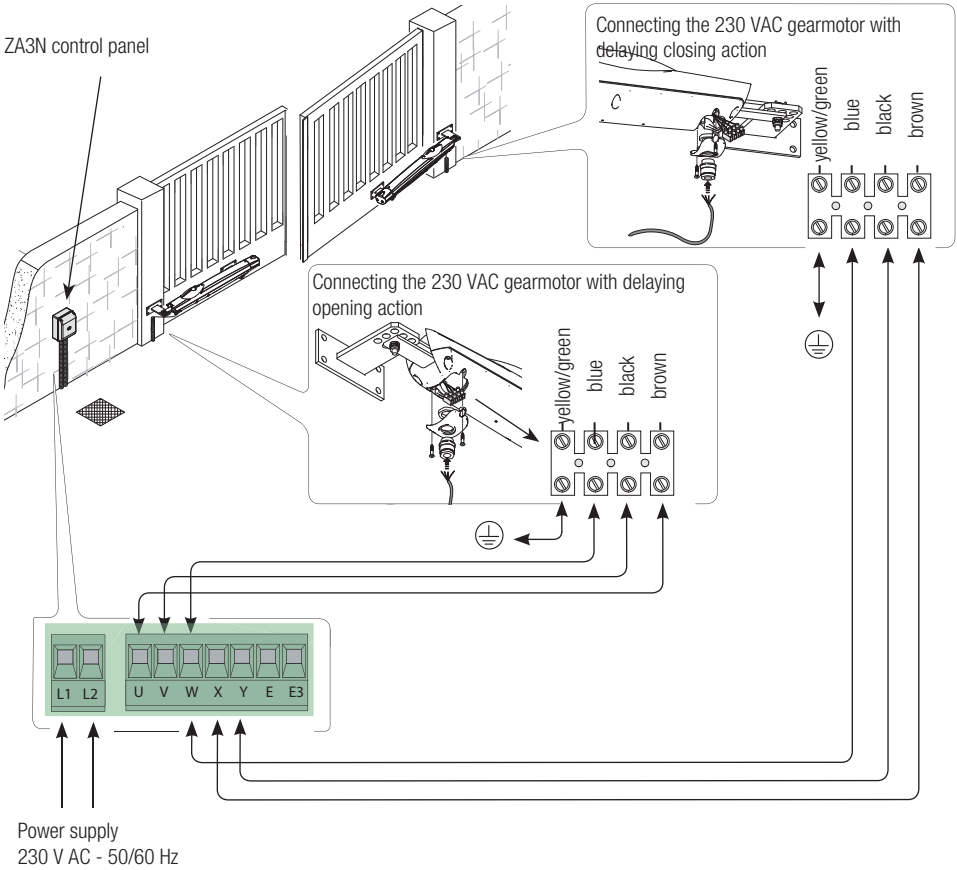

Installing and connection for outward opening

Leaf opening (°)	A (mm)	B (mm)	E (mm)
90°	130	130	720

Weld the additional bracket (not supplied) to the pillar bracket. Secure the additional bracket to the pillar respecting the values A and B shown in the table. Open the gate to 90°. Weld or secure the gate bracket using suitable screws, respecting the value E. Secure the gearmotor to the brackets using the screws and motors supplied.

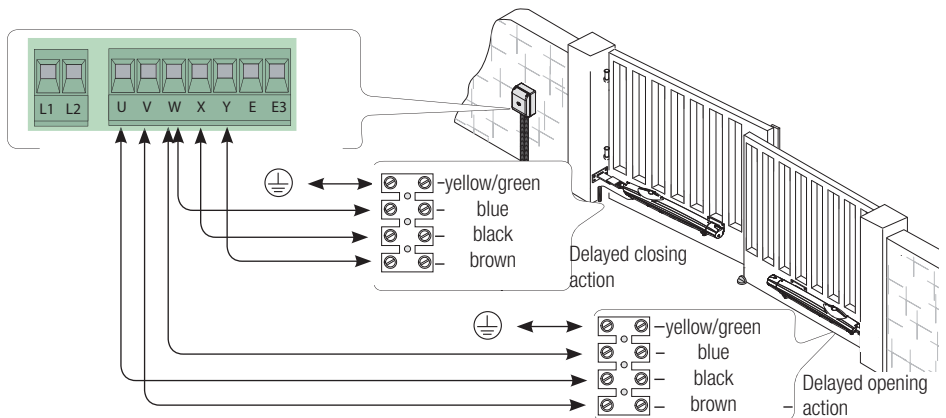
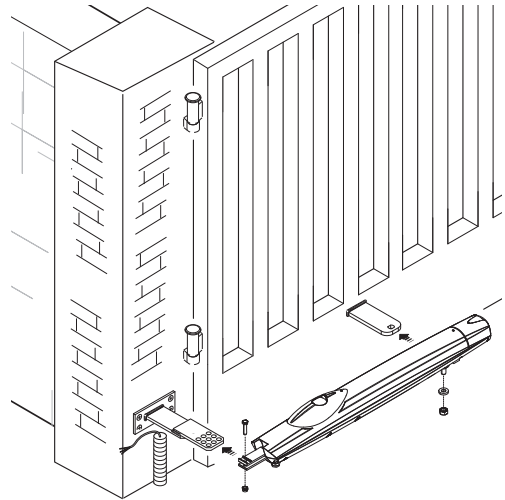
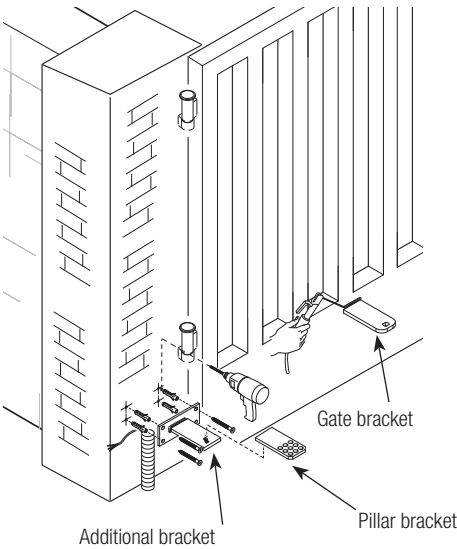
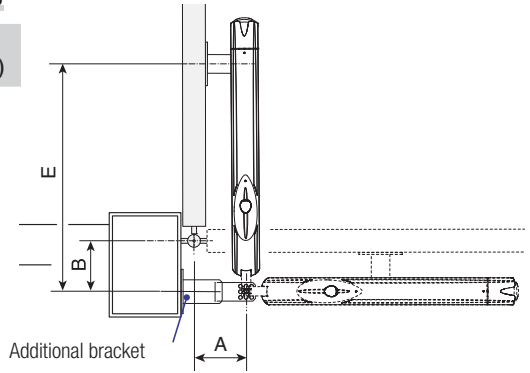

Periodic maintenance

It is advisable to check lubrication periodically and check that the operator fixing screws are tight. In the event of abnormal vibrations or squeaking, lubricate the joints with grease, as shown in the figure. Lubricate the worm screw through the slots on the pressure die-casting. The head cover (figure A) must be removed.

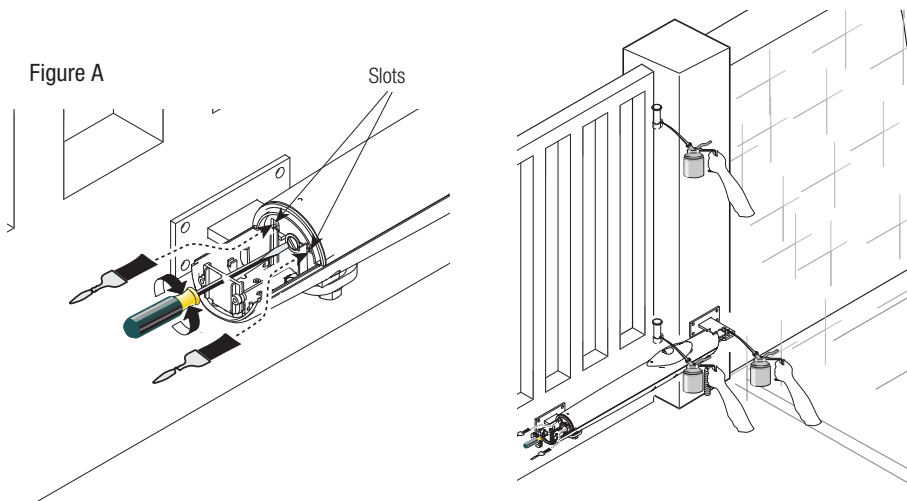

Periodic maintenance log to be completed by the user (every six months)

Date	Notes	Signature

Extraordinary maintenance

⚠ The table below is used to note any extraordinary maintenance, repairs or improvements carried out by specialist companies.

N.B.: Extraordinary maintenance must be carried out by specialist technicians.

Extraordinary maintenance log

Installation technician stamp	Operator name
	Date of intervention
	Technician signature
	Customer signature
Intervention carried out _____ _____ _____	

Installation technician stamp	Operator name
	Date of intervention
	Technician signature
	Customer signature
Intervention carried out _____ _____ _____	

Installation technician stamp	Operator name
	Date of intervention
	Technician signature
	Customer signature
Intervention carried out _____ _____ _____	

Installation technician stamp	Operator name
	Date of intervention
	Technician signature
	Customer signature
Intervention carried out _____ _____ _____	

Installation technician stamp	Operator name
	Date of intervention
	Technician signature
	Customer signature
Intervention carried out _____ _____ _____	

TROUBLESHOOTING

PROBLEM	POSSIBLE CAUSES	CHECKS AND REMEDIES
The gate does not open or close	<ul style="list-style-type: none">• No power• The gearmotor is unlocked• The transmitter battery is flat• The transmitter is broken• The stop button is stuck or broken• The opening/closing button or the key selector switch are stuck	<ul style="list-style-type: none">• Check for mains power• Contact service• Replace the battery• Contact service• Contact service• Contact service
The gate opens but does not close	<ul style="list-style-type: none">• The photocells are engaged	<ul style="list-style-type: none">• Check that the photocells are clean and work correctly• Contact service

DISMANTLING AND DISPOSAL

☞ CAME CANCELLI AUTOMATICI S.p.A. implements an EN ISO 14001-certified and compliant Environmental Management System at its plants, to ensure environmental protection.

Please continue our efforts to protect the environment, something that CAME considers to be one of the foundations in developing its business and market strategies, simply by observing brief recommendations as regards disposal:

♻️ DISPOSAL OF PACKAGING

Packaging components (cardboard, plastic etc.) can be disposed of together with normal household waste without any difficulty, by simply separating the different types of waste and recycling them.

Before proceeding, it is always advisable to check specific regulations in force in the place of installation.

DISPOSE OF PROPERLY!

♻️ DISPOSAL OF THE PRODUCT

Our products are made with different materials. Most of them (aluminium, plastic, iron, electrical cables) can be disposed of together with normal household waste. They can be recycled if collected, sorted and sent to authorised centres.

Other components (circuit boards, transmitter batteries etc.), on the other hand, may contain pollutants.

They should therefore be removed and handed over to companies authorised to recover and recycle them.

Before proceeding, it is always advisable to check specific regulations in force in the place of disposal.

DISPOSE OF PROPERLY!

DECLARATION OF CONFORMITY

Declaration CE - CAME S.p.A. declares that this device complies with the essential requirements and other relevant provisions established in Directives 2006/42/EC and 2014/30/UE.

An original copy of the declaration of conformity is available on request.

PAGE INTENTIONALLY LEFT BLANK



English - Manual code: **119DU80EN** vers. **2** 01/2015 © CAME S.p.A.
The data and information provided in this manual are subject to change at any time without prior notice by CAME S.p.A.

- IT** • Per ogni ulteriore informazione su azienda, prodotti e assistenza nella vostra lingua:
- EN** • For any further information on company, products and assistance in your language:
- FR** • Pour toute autre information sur la société, les produits et l'assistance dans votre langue :
- DE** • Weitere Infos über Unternehmen, Produkte und Kundendienst bei:
- ES** • Para cualquier información sobre la empresa, los productos y asistencia en su idioma:
- NL** • Voor meer informatie over het bedrijf, de producten en hulp in uw eigen taal:
- PT** • Para toda e qualquer informação acerca da empresa, de produtos e assistência técnica, em sua língua:
- PL** • Wszystkie inne informacje dotyczące firmy, produktów oraz usług i pomocy technicznej w Waszym języku znajdują się na stronie:
- RU** • Для получения дополнительной информации о компании, продукции и сервисной поддержке на вашем языке:
- HU** • A vállalatra, termékeire és a műszaki szervizre vonatkozó minden további információért az Ön nyelvén:
- HR** • Za sve dodatne informacije o poduzeću, proizvodima i tehničkoj podršci:
- UK** • Для отримання будь-якої іншої інформації про компанію, продукцію та технічну підтримку:



CAME
s a f e t y & c o m f o r t

CAME S.p.A.
Via Martiri Della Libertà, 15
31030 **Dossone Di Casier** (Tv)
☎ (+39) 0422 4940
📠 (+39) 0422 4941

Assistenza Tecnica/Numero Verde 800 295830