

## Control panel for 24 V gearmotors

FA01961-EN



**ZLX24SA**

**ZLX24SR**

**⚠ Important safety instructions.**

**⚠ Please follow all of these instructions. Improper installation may cause serious bodily harm.**

**⚠ Before continuing, please also read the general precautions for users.**

Only use this product for its intended purpose. Any other use is hazardous. • The manufacturer cannot be held liable for any damage caused by improper, unreasonable or erroneous use. • This product has been designed to be assembled to partly completed machinery and/or equipment so as to build machinery as regulated by the Machinery Directive 2006/42/EC. • The final installation must comply with the Machinery Directive (2006/42/EC) and the European reference standards in force. • The manufacturer declines any liability for using non-original products, which would also void the warranty. • All operations indicated in this manual must be carried out exclusively by skilled and qualified personnel and in full compliance with the regulations in force. • The device must be installed, wired, connected and tested according to good professional practice, in compliance with the standards and laws in force. • Make sure the mains power supply is disconnected during all installation procedures. • All the components (e.g. actuators, photocells and sensitive edges) needed for the final installation to comply with the Machinery Directive (2006/42/EC) and with the reference harmonised technical standards are specified in the general CAME product catalogue or on the website [www.came.com](http://www.came.com). • Check that the temperature ranges given are suitable for the installation site. • Make sure that no direct jets of water can wet the product at the installation site (sprinklers, water cleaners, etc.). • Make sure you have set up a suitable dual-pole cut-off device along the power supply that is compliant with the installation rules. It should completely cut off the power supply according to category III surcharge conditions. • Demarcate the entire site properly to prevent unauthorised personnel from entering, especially minors. • Use suitable protection to prevent any mechanical hazards due to persons loitering within the operating range of the operator. • The electrical cables must not touch any parts that may overheat during use (such as the motor and transformer).

- Before installation, check that the guided part is in good mechanical condition, and that it opens and closes correctly.
- The product cannot be used to automate any guided part that includes a pedestrian gate, unless it can only be enabled when the pedestrian gate is secured.
- Make sure that nobody can become trapped between the guided and fixed parts, when the guided part is set in motion. If you are automating a pedestrian gate that moves horizontally, this can be achieved if the corresponding distance is less than 8 mm. However, the distances indicated below are sufficient to avoid trapping the corresponding body parts:

- fingers, more than 25 mm;
- feet, more than 50 mm;
- head, more than 300 mm;
- for the entire body, more than 500 mm.

If you cannot achieve these distances, you will need to take suitable safety precautions.

- All fixed controls must be clearly visible after installation, in a position that allows the guided part to be directly visible, but far away from moving parts. In the case of a hold-to-run control, this must be installed at a minimum height of 1.5 m from the ground and must not be accessible to the public.
- Where operated with a hold-to-run control, install a STOP button to disconnect the main power supply to the operator, to block movement of the guided part.
- If not already present, apply a permanent tag that describes how to use the manual release mechanism close to it.
- Make sure that the operator has been properly adjusted and that the safety and protection devices and the manual release are working properly.
- Before handing over to the final user, check that the system complies with the harmonised standards and the essential requirements of the Machinery Directive (2006/42/EC).
- Any residual risks must be indicated clearly with proper signage affixed in visible areas, and explained to end users.
- Put the machine's ID plate in a visible place when the installation is complete.
- If the power supply cable is damaged, it must be immediately replaced by the manufacturer or by an authorised technical support service, or in any case, by qualified staff, to prevent any risk.
- Keep this manual inside the technical folder along with the manuals of all the other devices used for your automation system.
- Make sure to hand over to the end user all the operating manuals of the products that make up the final machinery.

- The product, in its original packaging supplied by the manufacturer, must only be transported in a closed environment (railway carriage, containers, closed vehicles).
- If the product malfunctions, stop using it and contact customer services at <https://www.came.com/global/en/contact-us> or via the telephone number on the website.

 The manufacture date is provided in the production batch printed on the product label. If necessary, contact us at <https://www.came.com/global/en/contact-us>.

 The general conditions of sale are given in the official CAME price lists.

## DISMANTLING AND DISPOSAL

 CAME S.p.A. employs an Environmental Management System at its premises. This system is certified and compliant with the UNI EN ISO 14001 standard to ensure that the environment is respected and safeguarded. Please continue safeguarding the environment. At CAME we consider it one of the fundamentals of our operating and market strategies. Please follow these brief disposal guidelines:

### DISPOSING OF THE PACKAGING

The packaging materials (cardboard, plastic, etc.) can be disposed of easily as solid urban waste, separated for recycling. Before dismantling and disposing of the product, please always check the local laws in force.

### DISPOSE OF THE PRODUCT RESPONSIBLY.

### DISPOSING OF THE PRODUCT

Our products are made of various materials. Most of these materials (aluminium, plastic, iron and electrical cables) are classified as solid urban waste. They can be separated for recycling and disposed of at authorised waste treatment plants. Other components (electronic boards, transmitter batteries, etc.) may contain pollutants.

These must be removed and disposed of by an authorised waste disposal and recycling firm.

It is always advisable to check the specific laws that apply in your area.

### DISPOSE OF THE PRODUCT RESPONSIBLY.

## PRODUCT DATA AND INFORMATION

### Key

 This symbol shows which parts to read carefully.

 This symbol shows which parts describe safety issues.

 This symbol shows what to tell users.

The measurements, unless otherwise stated, are in millimetres.

### Description

#### 801QA-0060

ZLX24SA - Multifunction control panel, with 230 VAC power supply, for 24 V swing gates with two leaves, with graphic programming display and signalling, safety device self-diagnostics, adaptive speed and torque technology, BUS CXN, 4 safety inputs and memory space for up to 1000 users.

#### 801QA-0080

ZLX24SR - Multifunction control panel, with 120 VAC power supply, for 24 V swing gates with two leaves, with graphic programming display and signalling, safety device self-diagnostics, adaptive speed and torque technology, BUS CXN, 4 safety inputs and memory space for up to 1000 users.

## Technical data

MODELS	ZLX24SA	ZLX24SR
Power supply (V - 50/60 Hz)	230 AC	120 AC
Motor power supply (V)	36 DC	36 DC
Board power supply (V)	26 AC	26 AC
Standby consumption (W)	3	3
Power (W)	360	360
Transformer thermal protection (°C)	120	120
Colour	RAL 7040	RAL 7040
Operating temperature (°C)	-20 ÷ +55	-20 ÷ +55
Storage temperature (°C)*	-25 ÷ +70	-25 ÷ +70
Cycles/hour	20	20
Consecutive cycles	20	20
Protection rating (IP)	54	54
Insulation class	I	I
Average life (cycles)**	100.000	100.000

(\*) Before installing the product, keep it at room temperature where it has previously been stored or transported at a very high or very low temperature.

(\*\*) The average product life is a purely indicative estimate. It applies to compliant usage, installation and maintenance conditions. It is also influenced by other factors, such as climatic and environmental conditions.

## Fuse table

MODELS	ZLX24SA	ZLX24SR
Line fuse	3.15 A F	4 A F
Control-board fuse	1.6 A T	1.6 A T
Accessory fuse	1.6 A F	1.6 A F



## Optional accessories

**24** RGS001 module (806SA-0010)

**25** SMA module (009SMA)

**26** RLB battery charger board (002RLB)

 To control all required motors from the control panel, use two 7Ah batteries (846XG-0030) installed on an external panel.

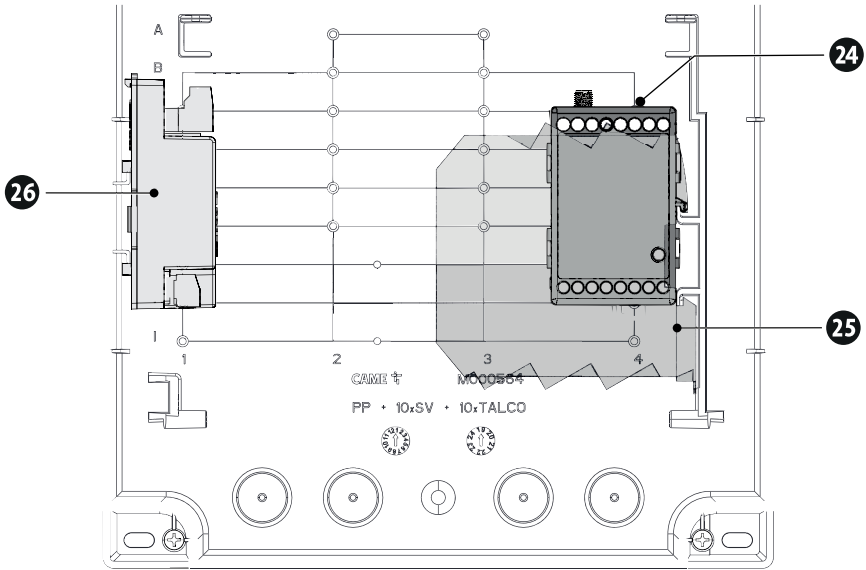

## Size

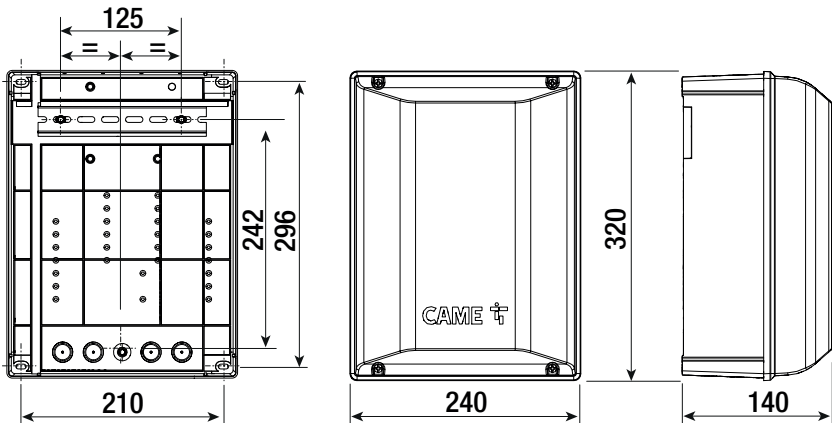



## Cable types and minimum thicknesses

Cable length (m)	up to 20	from 20 to 30
Power supply 230 V AC	3G x 1.5 mm <sup>2</sup>	3G x 2.5 mm <sup>2</sup>
24 V AC/DC flashing beacon	2 x 0.5 mm <sup>2</sup>	2 x 0.5 mm <sup>2</sup>
TX Photocells	2 x 0.5 mm <sup>2</sup>	2 x 0.5 mm <sup>2</sup>
RX photocells	4 x 0.5 mm <sup>2</sup>	4 x 0.5 mm <sup>2</sup>
12 V DC electric lock	2 x 1 mm <sup>2</sup>	2 x 1.5 mm <sup>2</sup>
Command and control devices	*no. x 0.5 mm <sup>2</sup>	*no. x 0.5 mm <sup>2</sup>

\* no. = see product assembly instructions

**Warning:** the cable cross-section is indicative and varies according to the motor power and cable length.

 When operating at 230 V and outdoors, use H05RN-F cables that are IEC 60245 (IEC 57) compliant; when indoors, use H05VV-F cables that are IEC 60227 (IEC 53) compliant; For power supplies up to 48 V, use FROR 20-22 II cables compliant with standard EN 50267-2-1 (CEI).

 To connect the antenna, use RG58 cable (up to 5 m).

 To connect to the CRP, use a UTP CAT5 cable (up to 1,000 m long).

 If the cable lengths differ from those specified in the table, define the cable cross-sections according to the actual power draw of the connected devices and in line with regulation CEI EN 60204-1.

 For multiple, sequential loads along the same line, recalculate the values in the table according to the actual power draw and distances. For information on connecting products not covered in this manual, please see the documentation accompanying the products themselves.

 To connect the encoder, use a FRORPU 3 x 0.5 mm<sup>2</sup> cable or a cable supplied by CAME on request (item code 801XA-0020).

### BUS cable table

 We recommend using a FROR 2x1mm<sup>2</sup> cable, maximum length from the control board: 50 m.

Single branch length (m)	max. 50 m
BUS cable	2 x 1 mm <sup>2</sup>

 The total length of all branches can be a maximum of 150 m.

 The cable cannot be shielded.



Preparing the control panel

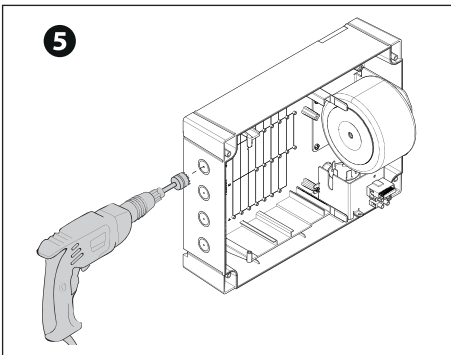
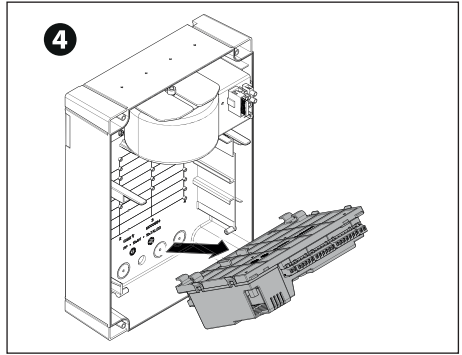
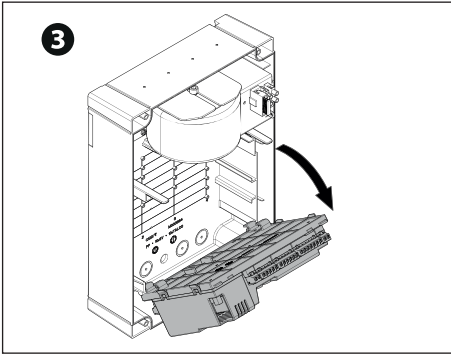
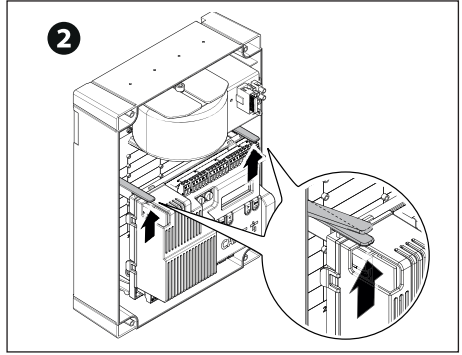
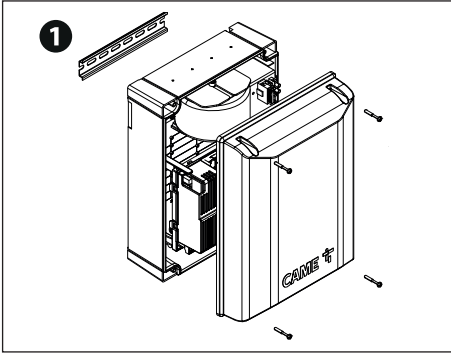

## Fastening the control panel

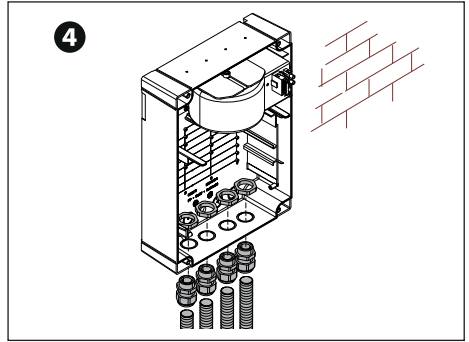
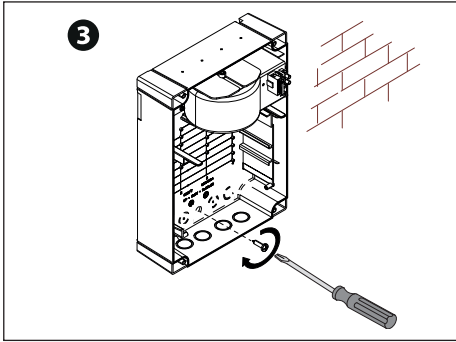
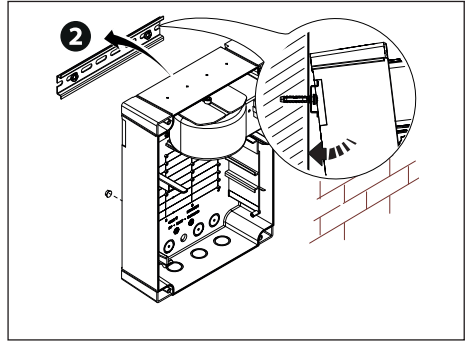
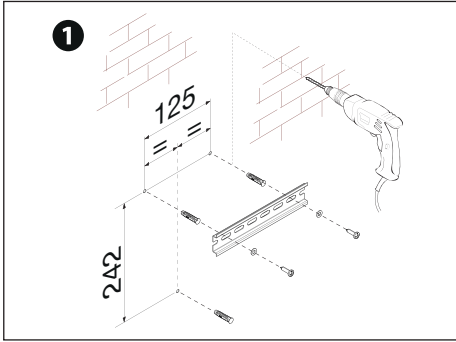

### DIN rail

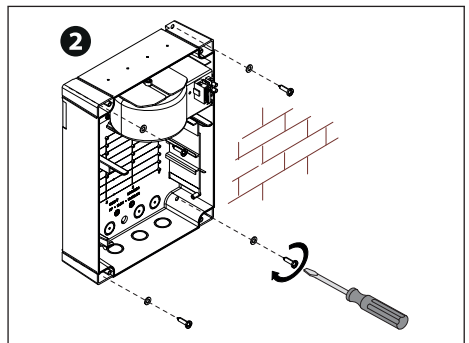
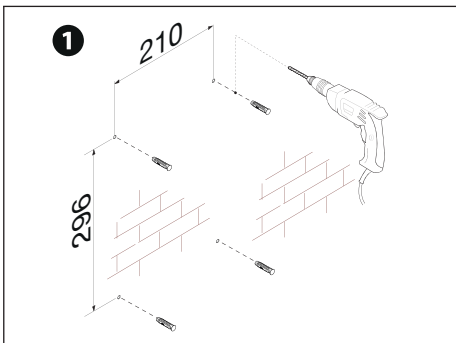

### Standard



## Preparing the electrical cables

-  Connect all wires and cables in compliance with the law.
-  Use cable glands to connect the devices to the control panel. One of these must be used exclusively for the power supply cable.

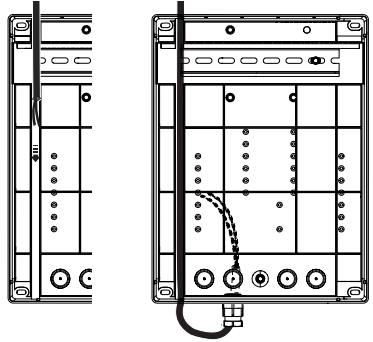
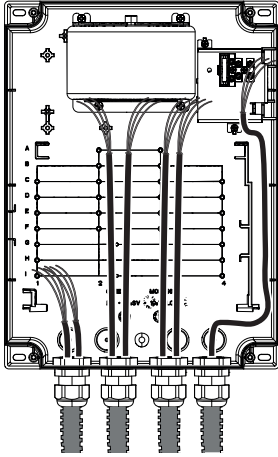

## Power supply

### 1 Connecting to the mains (230/120 V AC - 50/60 Hz)

F - Line fuse

L - Phase

N - Neutral

⊕ Earth

 The strap used to fix the cables is not supplied.

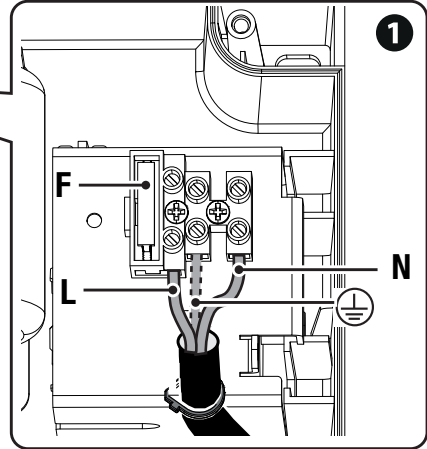
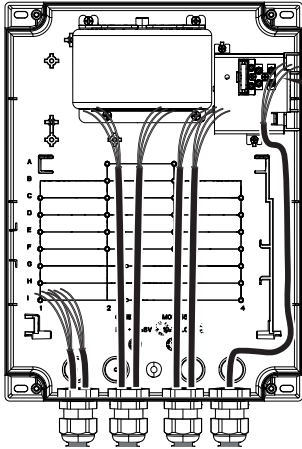

 For subsequent connections, reposition the control board and remove the board protection.

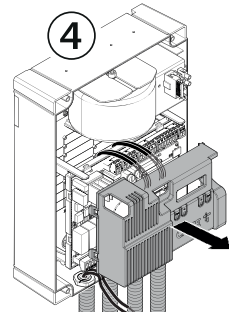
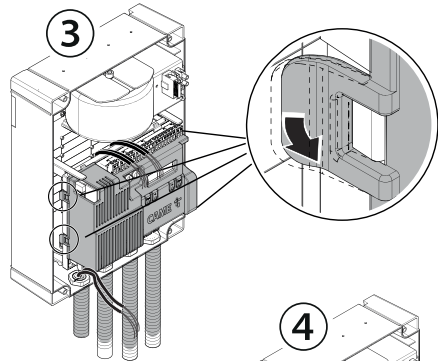
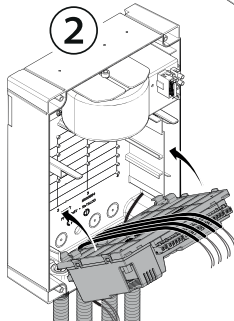
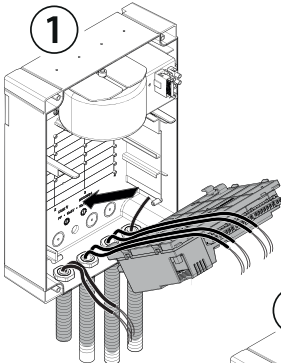

## 2 Power supply output for accessories

The output normally delivers 24 V AC.

The output delivers 24 V DC (10+, 11-) when the batteries start operating, if they are installed.

## 3 Electric lock or electromagnets 12 V AC/DC - max 15 W.

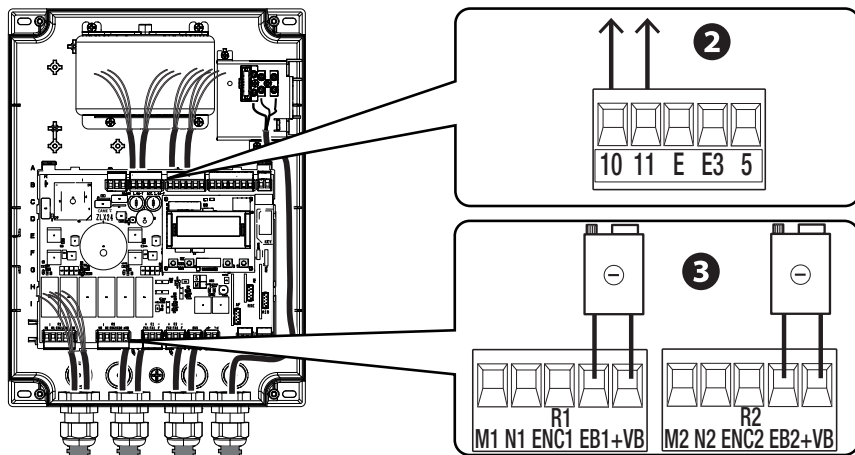

### Maximum capacity of contacts

The total power of the outputs listed below must not exceed the maximum output power [Accessories]

Device	Output	Power supply (V)	Maximum power (W)
Accessories	10 - 11	26 AC	20
Additional light	10 - E3	26 AC	10
Flashing beacon	10 - E	26 AC	10
Operator status warning light	10 - 5	26 AC	3

The outputs deliver 24 V DC when the batteries start operating, if they are installed.

Device	Output	Power supply (V)	Power (W)
Auxiliary contact	B1 - B2	- -	-
BUS CXN	BUS	15 DC -	-

Do not connect anything other than CAME BUS accessories.

## Gearmotors for swing operators

M1 = Gearmotor delayed while opening  
 M2 = Gearmotor delayed while closing

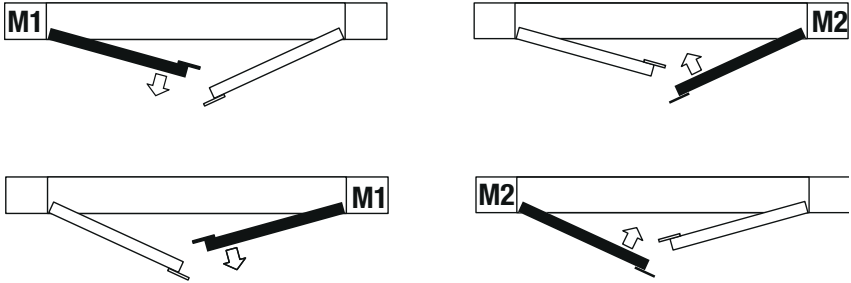

Where there is only one gearmotor in the system, make the electrical connections on the gearmotor (M2).

### Gearmotor with encoder

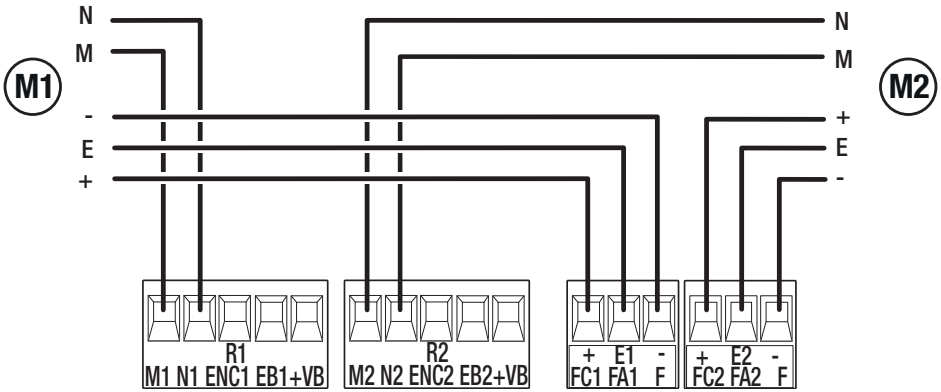

FROG-A24E / FERNI / FERNI-V / F4024E / F4024EP

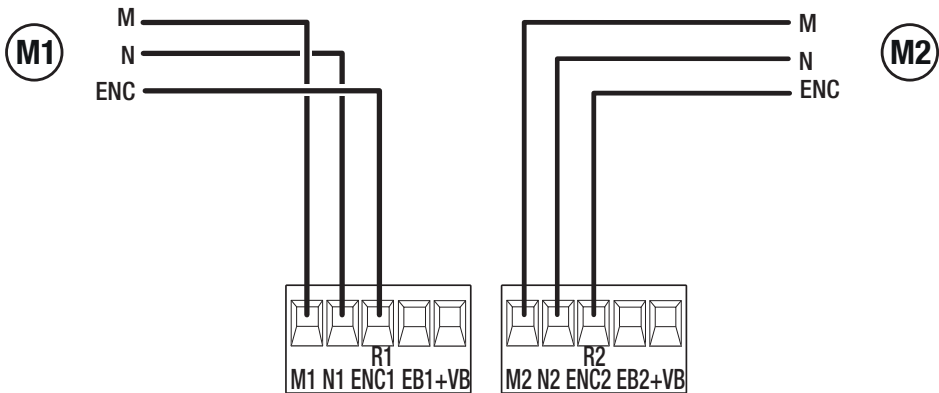

ATS / AXO / FTX / FAST-70 / AMICO / AXI

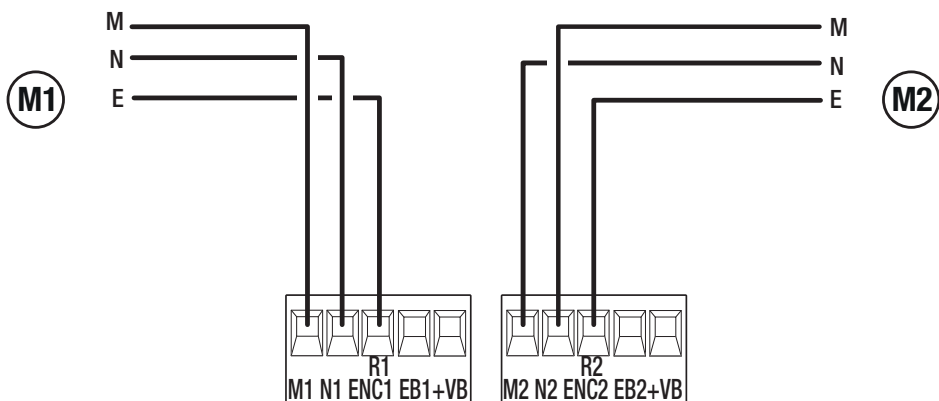

STYLO-RME

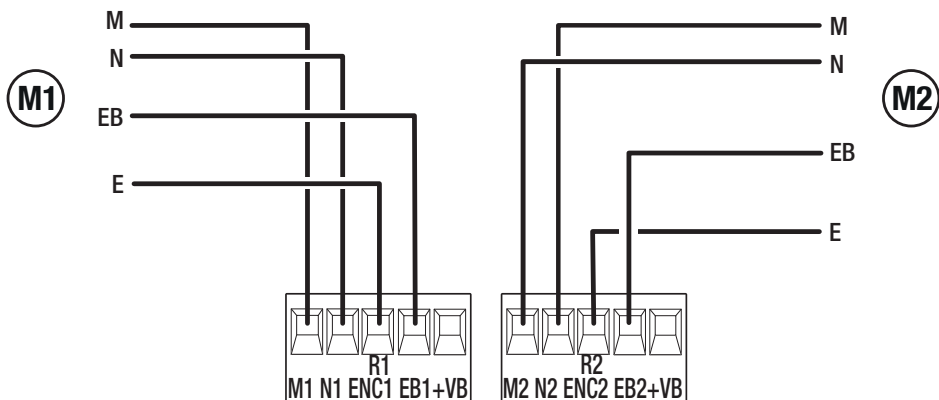

STYLO-ME

**Gearmotors with slowdown switches**

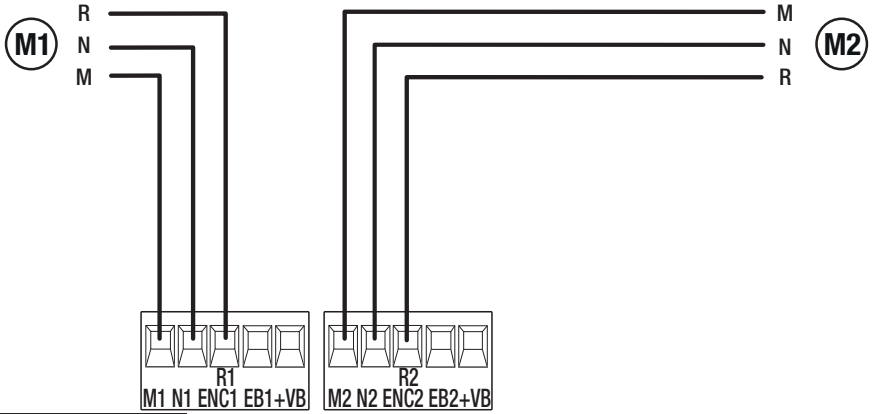

A3024N / A5024N

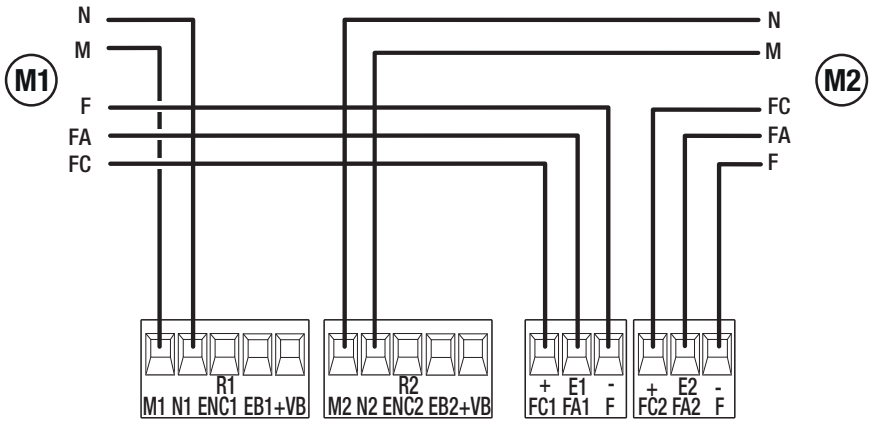

FROG-A24



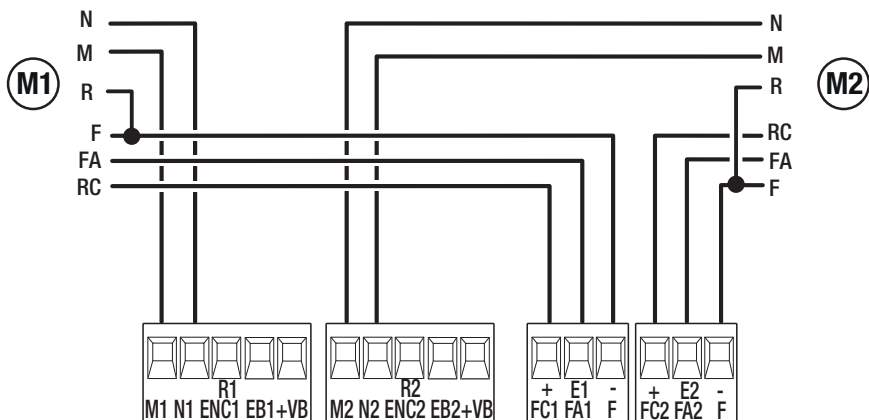

F1024

### Gearmotors without encoder

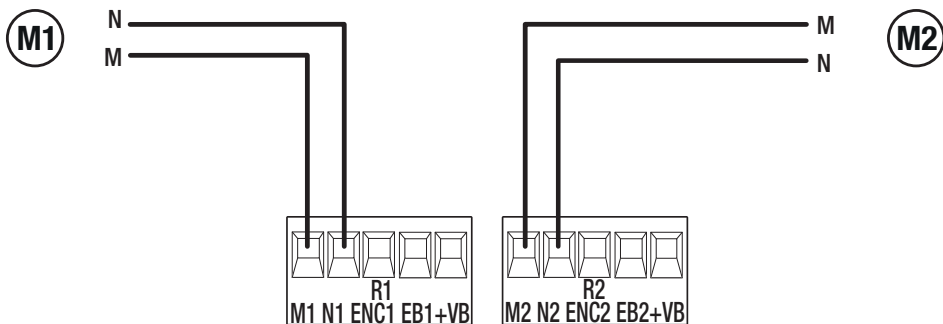

## Gearmotors for overhead operators

M1 and M2 are controlled as a pair and perform the same movements.

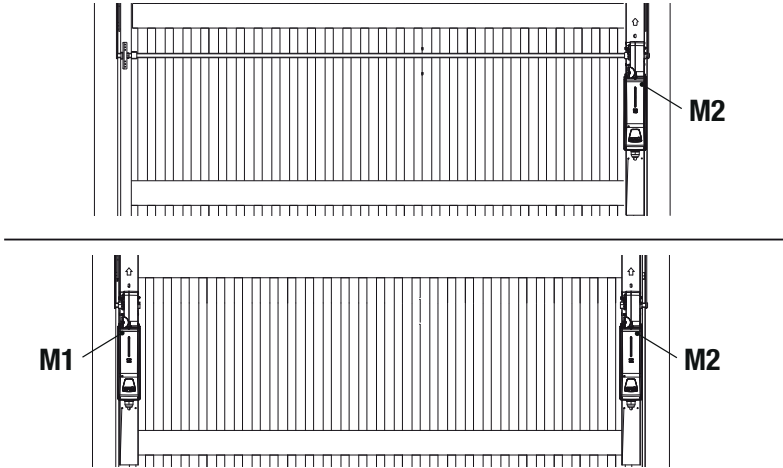

Where there is only one gearmotor in the system, make the electrical connections on the gearmotor (M2).

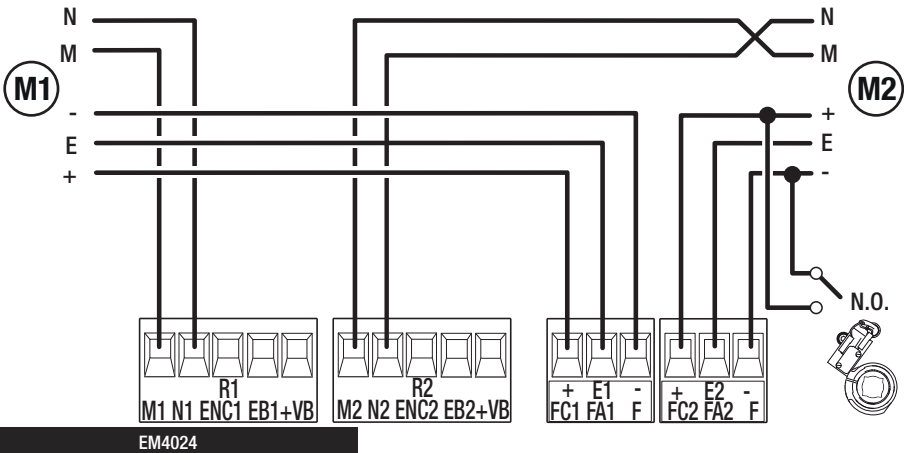

Ensure the [Motor type] function is set to EM4024.

## Devices with BUS CXN system

The CXN CAME system is a two-wire non-polarised communication BUS which allows you to connect up all compatible CAME devices.

Connection to the BUS can be in a chain, star or mixed formation.

Once the system has been wired, and after having set the address on each device, the function of each accessory can be configured on the control panel. This method allows you to configure the set-up immediately without having to do so later and intervene directly on the accessories and system wiring.

The CXN BUS can support control devices, interfaces, photocells, safety devices, beacons and gateways at the same time.

### Cabling

- 1 Chain connection
- 2 Star connection
- 3 Mixed connection

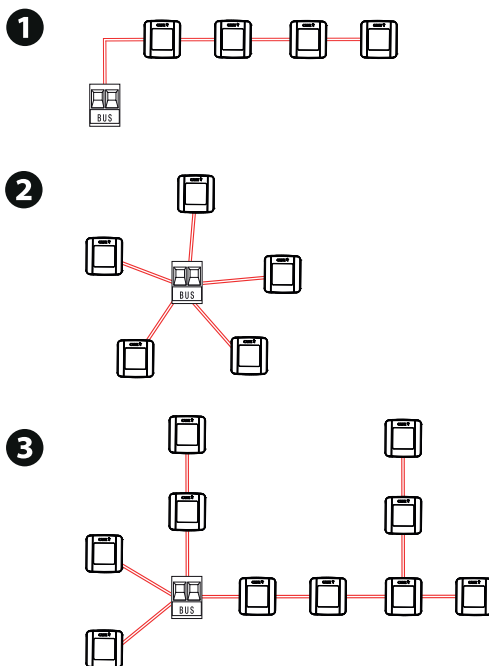

### Cable type

⚠ We recommend using a FROR 2x1mm<sup>2</sup> cable, maximum length from the control board: 50 m.

Single branch length (m)	max. 50 m
BUS cable	2 x 1 mm <sup>2</sup>

📖 The total length of all branches can be a maximum of 150 m.

📖 The cable cannot be shielded.

## Maximum number of devices that can be connected, by type

Type of device	Maximum number of devices per type
Selectors	7
Photocell pairs	8
Interfaces	2
Flashing beacons	2

## BUS CXN device consumption



Scan the QR code to access an interactive table showing consumption data, and calculate the maximum number of BUS devices you can connect to the control panel.

 BUS CXN device consumption is calculated in CXN units.

## Command and control devices

### 1 STOP button (NC contact)

This stops the operator and excludes automatic closing. Use a control device to resume movement.

 When the contact is being used, it must be activated during programming.

 See function [Total stop].

### 2 Control device (NO contact)

Open command

 When the [Hold-to-run] function is active, a control device must be set to OPEN.

### 3 Control device (NO contact)

Partial Opening or Pedestrian command

 See [Adjusting partial opening] function.

### 4 Control device (NO contact)

Close command

 When the [Hold-to-run] function is active, a control device must be set to CLOSE.

### 5 Control device (NO contact)

Step-by-step command

Sequential command

 See control [Function 2-7].

### 6 Antenna with RG58 cable

 If the chosen signalling device can be fitted with an antenna, use the terminal shown to connect it.

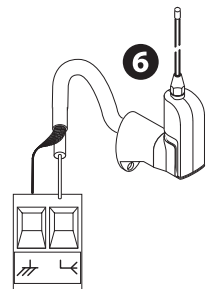
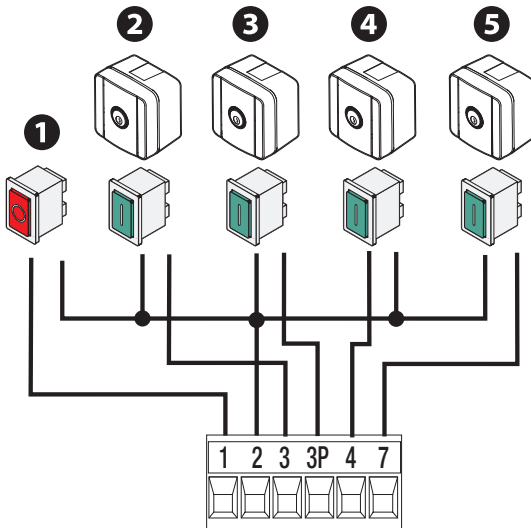

## Signalling devices

### ❶ Flashing beacon

It flashes when the operator opens and closes.

### ❷ Additional light

It increases the light in the manoeuvring area.

📖 See [Additional light] function.

### ❸ Operator status warning light

It notifies the user of the operator status.

📖 See function [Passage-open warning light].

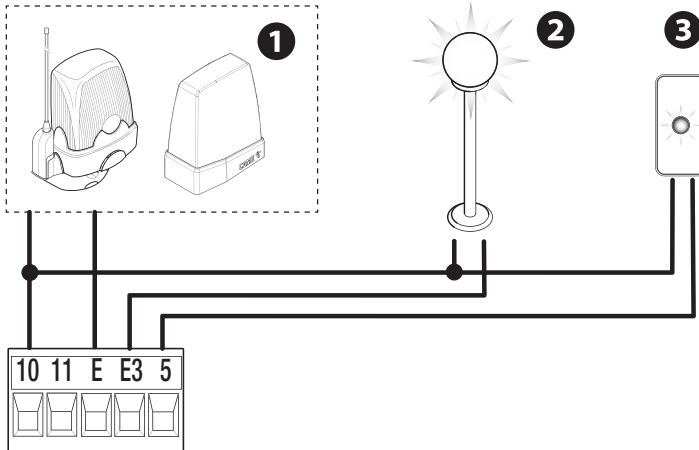

## Safety devices

During programming, configure the type of action that must be performed by the device connected to the input. Connect the safety devices to the CX and/or CY and/or CZ and/or CK inputs.

 If used, the contacts CX CY CZ CK must be configured during programming.

 For systems with multiple pairs of photocells, please see the manual for the relevant accessory.

### DELTA photocells

Standard connection

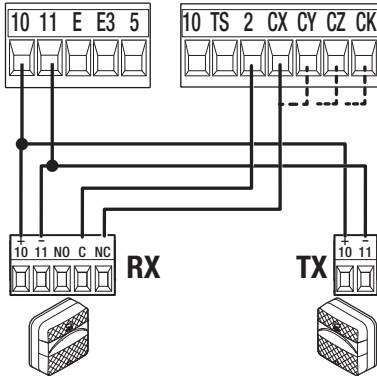

### DELTA photocells

Connection with safety test

 See [Safety devices test] function.

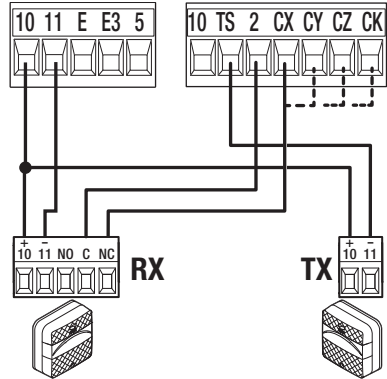

### DIR / DELTA-S photocells

Standard connection

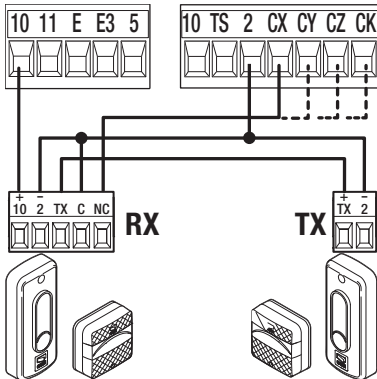

### DIR / DELTA-S photocells

Connection with safety test

 See [Safety devices test] function.

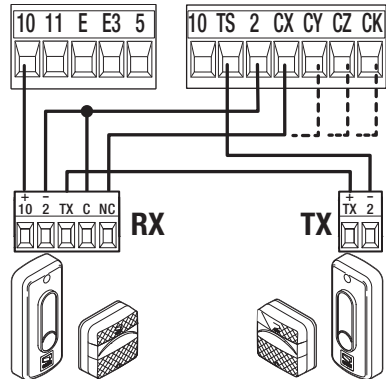

## DXR - DLX photocells

Standard connection

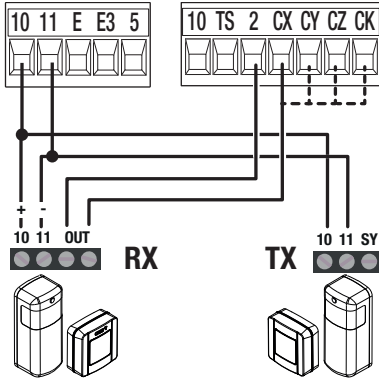

## DXR - DLX photocells

Connection with safety test

See [Safety devices test] function.

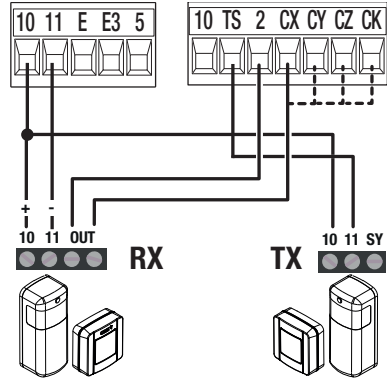

## DFWN sensitive edge

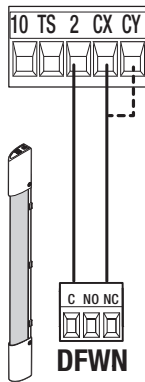



## Programming button functions

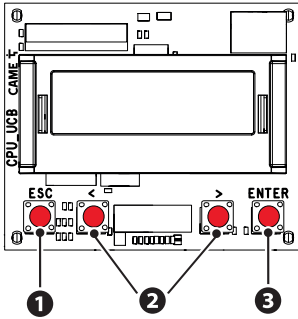

### 1 ESC button

The ESC button is used to perform the operations described below.

- Exit the menu
- Delete the changes
- Go back to the previous screen
- Stop the operator

### 2 < > buttons

The < > buttons are used to perform the operations described below.

- Navigate the menu
- Increase or decrease values

### 3 ENTER button

The ENTER button is used to perform the operations described below.

- Access menus
- Confirm choice

Outside the menu, the ESC key stops the gate and the < > keys open and close the gate.

When executing a manoeuvre, press and hold the ENTER key to display the Opening, Partial Opening, Closing and Stop commands. You can select the desired command using the < > keys.

## Getting started

Once the electrical connections have been made, proceed with commissioning. Only skilled and qualified staff may perform this operation.

Make sure that there are no obstacles in the way.

Power up the device and follow the instructions on the display.

Start programming following the wizard.

If this is not the first time the board is being switched on, go to the menu Configuration > Wizard. Follow the indications shown on the display.

Complete programming and check the warning, safety and protection devices, and the manual release, are working properly.

After powering up the system, the first manoeuvre is always to open the gate. Wait for the manoeuvre to be completed.

Perform the first manoeuvre where you can see the gate in motion and with the photocells active, including where remotely controlled.

Press the ESC button or STOP button immediately in the event of any faults, malfunctions, strange noises or vibrations, or unexpected behaviour in the system.

If CALIBRATION REQUIRED appears on the display, you must calibrate the travel. The panel will not accept motion commands, except for the motor test.

## Diagrams showing leaf speed, slowdown and approach points

- 1 Closing limit-switch
- 2 Opening limit-switch
- 3 Opening slowdown point
- 4 Closing slowdown point
- 5 Opening approach point
- 6 Closing approach point

- A Opening speed
- B Closing speed
- C Opening slowdown speed
- D Closing slowdown speed
- E Approach speed (fixed)
- F Invert-motion zone in case of obstructions
- G Stop-motion zone in case of obstructions

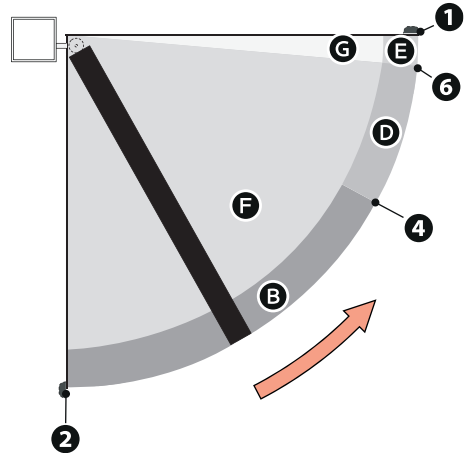
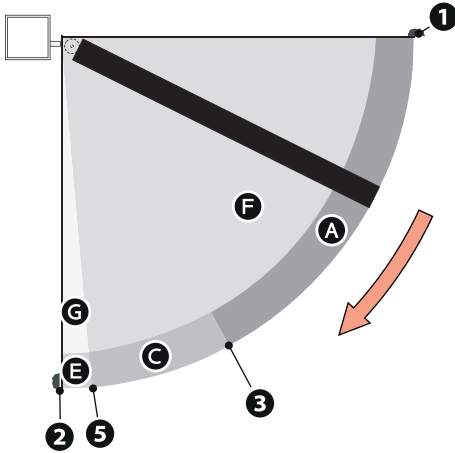

## Graph showing speed curves during movement, slowdown and approach.

📖 Moving between the various speeds always involves a gentle acceleration/slowdown slope.

## Using slowdown space (slowdown space > 0)

📖 With a slowdown space greater than 0, the obstruction detector, when near the approach points, is more sensitive, as per the impact testing.

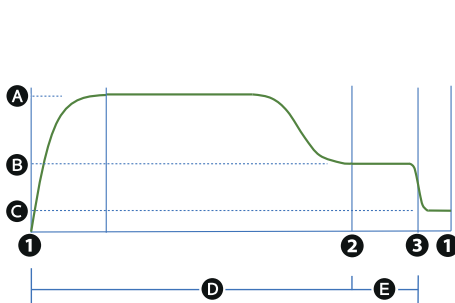

- A Opening or closing speed
- B Opening or closing slowdown speed
- C Approach speed (fixed)
- D Obstruction travel sensitivity
- E Slowdown obstruction sensitivity
- 1 Opening or closing limit-switch
- 2 Opening or closing slowdown point
- 3 Opening or closing approach point

## Without using slowdown space (slowdown space = 0)

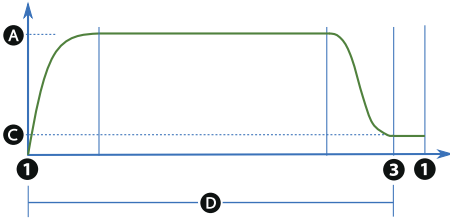

- A** Opening or closing speed
- C** Approach speed (fixed)
- D** Obstruction travel sensitivity
- 1** Opening or closing limit-switch
- 3** Opening or closing approach point

### Virtual encoder

For gearmotors without an encoder or with the encoder deactivated, travel is managed using a VIRTUAL ENCODER.

**ALWAYS** calibrate the travel, as with motors with an encoder.

**If, during calibration (no encoder), the panel does not automatically detect the strike plate signalling a change of status on the display (in the order CL1, CL2, OP2, OP1), repeat the operation as follows:**

- Close M1 and "CL1" appears on the display. When it hits the strike plate, press the ENTER button.
  - Close M2 and "CL2" appears on the display. When it hits the strike plate, press the ENTER button.
  - Open M2 and "OP2" appears on the display. When it hits the strike plate, press the ENTER button.
  - Open M1 and "OP1" appears on the display. When it hits the strike plate, press the ENTER button.
  - The message Calibration Complete shows on the display, followed by the symbol, to signal that the encoder is deactivated.
- Deactivating the encoder results in lower accuracy on slowdown points, approach points and obstacle detection. With AST control on slowdown deactivated, the gate will behave in the same way on both approach and slowdown and the detection of an obstacle will be interpreted as a travel end point.

Managing the travel and related parameters is done in the same way as described for motors with an encoder.

## Functions menu

---

### Menu layout

Some options only show on the display if certain conditions are met. For more information, please see the information for the individual functions.

Level 1	Level 2	Level 3	Level 4
Configuration	Motor settings	Number of motors	
		Motor type	
		Encoder	
		Reduce speed	
		Limit-switch function	
		Input type FC/FA	
		Motor test	
		Travel calibration	
		Motor power	
		Configure M1	
Configure M2	Motor type Encoder Limit-switch function Input type FC/FA Reduce speed Motor power		

Gate travel settings	Opening speed	
	Closing speed	
	Travel AST control	
	Soft start	
	Part. open point	
	Op. approach point	
	Cl. approach point	
	Opening slowdown point	
	Closing slowdown point	
	Opening slowdown speed	
	Closing slowdown speed	
	Slowdown AST control	
	Impact test	
Configure M1	Opening speed	
	Closing speed	
	Op. approach point	
	Cl. approach point	
	Opening slowdown point	
	Closing slowdown point	
	Opening slowdown speed	
	Closing slowdown speed	
Configure M2	Opening speed	
	Closing speed	
	Op. approach point	
	Cl. approach point	
	Opening slowdown point	
	Closing slowdown point	
	Opening slowdown speed	
	Closing slowdown speed	

Wired safety devices	Total stop	
	CX input	
	CY input	
	CZ input	
	CK input	
	Safety devices test	
RIO safety devices	RIO ED T1	
	RIO ED T2	
	RIO PH T1	
	RIO PH T2	
BUS Devices	BUS Photocell 1	
	Photocell BUS 2	
	Photocell BUS 3	
	Photocell BUS 4	
	Photocell BUS 5	
	Photocell BUS 6	
	Photocell BUS 7	
	Photocell BUS 8	
	BUS 1 key selector	Key to the right Key to the left
	BUS 2 key selector	Key to the right Key to the left
	BUS 3 key selector	Key to the right Key to the left
	BUS 4 key selector	Key to the right Key to the left
	BUS 5 key selector	Key to the right Key to the left

	BUS 6 key selector	Key to the right Key to the left
	BUS 7 key selector	Key to the right Key to the left
	I/O module BUS 1	input I1 input I2 Light output Relay output
	I/O module BUS 2	input I1 input I2 Light output Relay output
	BUS flashing beacon	Opening colour Closing colour Auto. cl. colour Pre-flashing colour Signal error
	BUS device lights	Signal maintenance
Command inputs	Command 2-7	
Functions	Lock Closing thrust Thrust Removing obstacles B1-B2 output Hold-to-run Obst. with motor stopped	

	Times	Automatic close	
		Automatic partial close	
		M1 open delay	
		M2 close delay	
	Manage lights	Passage-open warning light	
		Additional light	
		Courtesy time	
		Pre-flashing time	
	RSE communication	CRP address	
		RSE speed	
	External memory	Save data	
		Read data	
	Parameter reset		
	Guided procedure (Wizard)		
Manage users	New user		
	Remove user		
	Remove all		
	Radio decoding		
	Self-Learning Rolling		
	Change mode		
Information	FW version		
	BUS device status		
	Manoeuvre counter		
	Configure maintenance		
	Maintenance reset		
	Errors list		



Timer management	Show clock			
	Set the clock			
	Automatic DST			
	Time format			
	Create new timer	Open	Start time _____	End time _____
			Days of the week	
		Partial opening	Start time _____	End time _____
			Days of the week	
	B1-B2 output	Start time _____	End time _____	
		Days of the week		
	BUS 1 module relay	Start time _____	End time _____	
		Days of the week		
	BUS 2 module relay	Start time _____	End time _____	
		Days of the week		
	Remove timer			
Language				
Password	Enable password			
	Remove password			
	Change password			

## Functions menu

---

## Number of motors

Set the number of motors that control the gate.

Configuration> Motor settings	Number of motors	M1+M2 (Default) M2
----------------------------------	------------------	-----------------------

## Motor type

Set the type of gearmotor installed on M1 and M2.

 If the value set for M1 is different to the value set for M2, only the value for M2 is shown here.

Configuration> Motor settings	Motor type	Generic STYLO-ME STYLO-RME FTX FAST-70 AXI A1824 FERNI FERNI-V AXO A3024N/A5024N FROG-A24 FROG-A24E (Default) ATS F1024 F4024E F4024EP EM4024  Selecting EM4024, M1 and M2 are controlled as a pair and perform the same movements. Check that the same opening and closing direction is set on both motors.
----------------------------------	------------	---

## Encoder

Use the encoder input from the motor.

 The parameter is only available for motors that have an encoder.

 If the value set for M1 is different to the value set for M2, only the value for M2 is shown here.

Configuration> Motor settings	Encoder	Activated (Default) Off
----------------------------------	---------	----------------------------

## Reduce speed





Reduce the minimum voltage applicable to the motor.

 The parameter is only available for the Stylo ME and Stylo RME motors.

Configuration> Motor settings	Reduce speed	0% to 50% (Default 0%)
----------------------------------	--------------	------------------------

### Limit-switch function



Set the operation of the inputs for slowdown/end-of-travel switches.

-  **The function only appears for motors configured for this purpose.**
-  **If the value set for M1 is different to the value set for M2, only the value for M2 is shown here.**
-  **After modifying the function of the slowdown/end-of-travel inputs, recalibrate [Function Travel calibration].**
-  **If the inputs are used for slowdown, once calibration is complete, the board automatically sets the slowdown points. These parameters can, however, be modified. They allow for slowdown even if the slowdown switch is not seen.**
-  **The type of input (N.O. or N.C.) can be modified only with the generic motor [Function Type of limit switch]. In all other cases, use the type envisaged by the specific motor.**

Configuration> Motor settings	Limit-switch function	Off Stop in FA, stop in FC Slowdown in FA/FC Stop in FA, slowdown in FC
----------------------------------	-----------------------	--

### Input type FC/FA

Set the inputs type FC/FA.



-  **The function appears only with generic motors [Function Motor Type set to Generic].**
-  **The function only appears if the [Limit-switch function] is active.**

Configuration> Motor settings	Input type FC/FA	N.O. (Default) N.C. N.C. for FA input, N.O. for FC input
----------------------------------	------------------	--

### Motor test

Check the gate leaves open in the right direction.

With the function active, the > key opens/closes the gate leaf connected to M2, and the < key opens/closes the gate leaf connected to M1. The movement continues while the key is pressed or until the end-of-travel limit switch is reached. When the key is released, the movement stops.

-  **If the leaf does not move in the correct direction, invert the motor phases.**
-  **The leaves will move at reduced speed.**

Configuration> Motor settings	Motor test	The > key opens and closes gate leaf M2 The < key opens and closes gate leaf M1  <b>Every time the key is pressed (&gt; for M2 and &lt; for M1), the leaf direction changes from open to closed and vice versa. The change of direction is notified on the display.</b>
----------------------------------	------------	--

### Travel calibration

Start the travel self-learning.

Configuration> Motor settings	Travel calibration	
----------------------------------	--------------------	--

## Motor power

Increase or decrease the maximum thrust of motors connected on M1 and M2 during a manoeuvre.

 **Decreasing the thrust increases the obstacle-detection sensitivity.**

Configuration> Motor settings	Motor power	30% to 130% (Default 100%)  <b>At 100%, the maximum thrust is the one pre-defined for the type of motor set. Increasing or decreasing the percentage increases or decreases the maximum thrust.</b>
----------------------------------	-------------	---

## Configure motor M1

Modify certain parameters previously described for motor M1 only (where different from M2).

 **The function only appears with M1+M2 selected under [Number of motors].**

Configuration> Motor settings Configure motor M1	Motor type Encoder Limit-switch function Input type FC/FA Reduce speed Motor power	 <b>See the specific parameters for each function.</b>
--	---	---

## Configure motor M2

Modify certain parameters previously described for motor M2 only (where different from M1).

 **The function only appears with M1+M2 selected under [Number of motors].**

Configuration> Motor settings Configure motor M2	Motor type Encoder Limit-switch function Input type FC/FA Reduce speed Motor power	 <b>See the specific parameters for each function.</b>
--	---	---

## Opening speed

Set the opening speed for both motors (percentage of maximum speed).

 **If the value set for M1 is different to the value set for M2, only the value for M2 is shown here.**

Configuration> Gate travel settings	Opening speed	40% to 100% (Default 70%)
--	---------------	---------------------------

## Closing speed

Set the closing speed for both motors (percentage of maximum speed).

 **If the value set for M1 is different to the value set for M2, only the value for M2 is shown here.**

Configuration> Gate travel settings	Closing speed	40% to 100% (Default 70%)
--	---------------	---------------------------

## Travel AST control

Adjust the obstruction detection sensitivity during the gate travel in percentage terms.

Configuration>  
Gate travel settings

### Travel AST control

Deactivated (Default)

Minimum

Average

Maximum

 **Deactivated = Maximum thrust and low obstruction sensitivity.**

 **Maximum = Minimum thrust and high obstruction sensitivity.**

Customised

Customised closing

Customised opening

The personalised values to be used are expressed as a percentage:

- from 10% (minimum thrust and high obstruction sensitivity)

- to 100% (maximum thrust and low obstruction sensitivity)

## Slowed start when closing

Set the percentage of the total travel to be used for the slow start after each closing command.

 **The function appears only with [Motor type] set to EM4024.**

Configuration>  
Gate travel settings

### Soft start

Deactivated (Default)

1% to 30%

## Adjusting the partial opening

For single-leaf gates, it determines the partial opening percentage of the leaf with respect to the total travel.

For two-leaf gates, it determines the partial opening percentage of the M2 leaf with respect to the total travel.

Configuration>  
Gate travel settings

### Part. open point

10% to 100% (Default 100%)

 **100% = Pedestrian opening**

## Opening approach space

Set the percentage of the total travel to be used for the M1 and M2 opening approach.

 **If the value set for M1 is different to the value set for M2, only the value for M2 is shown here.**

Gate travel settings  
Configuration>

### Op. approach point

0.5% to 25.0% (Default 8.0%)

## Closing approach space

Set the percentage of the total travel to be used for the M1 and M2 closing approach.

 **If the value set for M1 is different to the value set for M2, only the value for M2 is shown here.**

Configuration>  
Gate travel settings

### Cl. approach point

0.5% to 25.0% (Default 8.0%)

### Opening slowdown space

Set the percentage of the total travel in which M1 and M2, after the slowdown point during opening, proceed at a slowed constant speed.

 If the value set for M1 is different to the value set for M2, only the value for M2 is shown here.

 To configure M1 or M2 separately, use the “Configure M1” or “Configure M2” menu.

 With the function deactivated, the gate still slows down near the approach space.

Configuration> Gate travel settings	Opening slowdown point	Deactivated (Default) 1% to 50%
--	------------------------	------------------------------------

### Closing slowdown space

Set the percentage of the total travel in which M1 and M2, after the slowdown point during closing, proceed at a slowed constant speed.

 If the value set for M1 is different to the value set for M2, only the value for M2 is shown here.

 To configure M1 or M2 separately, use the “Configure M1” or “Configure M2” menu.

 With the function deactivated, the gate still slows down near the approach space.

Configuration> Gate travel settings	Closing slowdown point	Deactivated (Default) 1% to 50%
--	------------------------	------------------------------------

### Opening slowdown speed

Set the M1 and M2 slowdown speed during opening (as a percentage of the maximum speed).

 If the value set for M1 is different to the value set for M2, only the value for M2 is shown here.

 The parameter is only used with the [Opening slowdown point] function active.

 For Stylo ME and Stylo RME motors it might be necessary to reduce the minimum voltage applicable to the motor to achieve the desired slowdown percentage. See function [Reduction of speed].

Configuration> Gate travel settings	Opening slowdown speed	10% to 50% (Default 40%)
--	------------------------	--------------------------

### Closing slowdown speed

Set the M1 and M2 slowdown speed during closing (as a percentage of the maximum speed).

 If the value set for M1 is different to the value set for M2, only the value for M2 is shown here.

 The parameter is only used with the [Closing slowdown point] function active.



 For Stylo ME and Stylo RME motors it might be necessary to reduce the minimum voltage applicable to the motor to achieve the desired slowdown percentage. See function [Reduction of speed].

Configuration> Gate travel settings	Closing slowdown speed	10% to 50% (Default 40%)
--	------------------------	--------------------------

### Slowdown AST control

Adjust the obstruction detection sensitivity during slowdown in percentage terms.



 **The parameter is only used if the opening or closing slowdown point is active.**

<p>Configuration&gt; Gate travel settings</p>	<p><b>Slowdown AST control</b></p>	<p>Deactivated (Default) Minimum Average Maximum  <b>Deactivated = Maximum thrust and low obstruction sensitivity.</b>  <b>Maximum = Minimum thrust and high obstruction sensitivity.</b></p> <p>Customised Customised closing Customised opening</p> <p>The personalised values to be used are expressed as a percentage: - from 10% (minimum thrust and high obstruction sensitivity) - to 100% (maximum thrust and low obstruction sensitivity)</p>
---	------------------------------------	--

### Impact test

Activate/deactivate test mode for impact tests. With the function on, the operator does not signal errors connected to obstacle detection after more than one consecutive impact.

 **Test mode is deactivated automatically after 1 hour.**

 **With the function on, the display shows the  icon.**

<p>Configuration&gt; Gate travel settings</p>	<p><b>Impact test</b></p>	<p>Activate test mode Deactivate test mode</p>
---	---------------------------	--

### Configure travel M1

Modify certain parameters previously described for motor M1 only (where different from M2).

 **The function only appears with M1+M2 selected under [Number of motors].**

 **The function does not appear with EM4024 motors [Motor type function set to EM4024].**

<p>Configuration&gt; Gate travel settings&gt; Configure M1</p>	<p>Opening speed Closing speed Opening approach space Closing approach space Opening slowdown space Closing slowdown space Opening slowdown speed Closing slowdown speed</p>	<p> <b>See the specific parameters for each function.</b></p>
--	--	--

## Configure travel M2

Modify certain parameters previously described for motor M2 only (where different from M1).

 **The function only appears with M1+M2 selected under [Number of motors].**

 **The function does not appear with EM4024 motors [Motor type function set to EM4024].**

Configuration> Gate travel settings> Configure M2	Opening speed Closing speed Opening approach space Closing approach space Opening slowdown space Closing slowdown space Opening slowdown speed Closing slowdown speed	 See the specific parameters for each function.
---	--	--

## Total stop

Activate or deactivate input 2-1. If it is activated, the input is used as a normally closed contact.

 **With the input open, this function excludes all commands, including any automatic closing.**

Configuration> Wired safety devices	Total stop	Deactivated (Default) On
--	------------	-----------------------------

## CX input , CY input , CZ input , CK input

Associate a function with the input CX or CY or CZ or CK

Configuration> Wired safety devices	CX input CY input CZ input CK input	Deactivated (Default) C1 = Reopen while closing (photocells) C2 = Reclose while opening (photocells) C3 = Partial stop Only with [Automatic close] activated. C4 = Obstacle standby (photocells) C7 = Reopen while closing (sensitive edges) C8 = Reclose while opening (sensitive edges) C13 = Reopen while closing, with immediate closure once the obstruction has been removed, even if the gate is not in motion r7 = Reopen while closing (sensitive edge with 8K2 resistor) r8 = Reopen while opening (sensitive edge with 8K2 resistor) r7 (two sensitive edges) = Reopen while closing (pair of sensitive edges with 8K2 resistor) r8 (two sensitive edges) = Reopen while closing (pair of sensitive edges with 8K2 resistor)
--	--	--



## Safety devices test

Check that the photocells connected to the selected inputs are operating correctly, after each opening and closing command.

 **Run the test by connecting the photocells to the TS terminal [see paragraph on Safety devices].**

Configuration>  
Wired safety devices

**Safety devices test**

Deactivated (Default)

CX \_\_\_  
 \_ CY \_\_\_  
 CX CY \_\_\_  
 \_\_ CZ \_\_\_  
 CX \_ CZ \_\_\_  
 \_ CY CZ \_\_\_  
 CX CY CZ \_\_\_  
 \_\_\_ CK  
 CX \_\_\_ CK  
 \_ CY \_ CK  
 CX CY \_ CK  
 \_\_ CZ CK  
 CX \_ CZ CK  
 \_ CY CZ CK  
 CX CY CZ CK

## RIO ED T1 and RIO ED T2

Associate one of the available functions with a wireless safety device.

 **The function only appears if the RIO CONN interface board is present.**

Configuration>  
RIO safety devices

**RIO ED T1  
RIO ED T2**

Deactivated (Default)

P0 = It stops the gate and excludes automatic closing. Use a control device to resume movement.  
 P7 = Reopen while closing.  
 P8 = Reclose while opening.

## RIO PH T1 and RIO PH T2

Associate one of the available functions with a wireless safety device.

 **The function only appears if the RIO CONN interface board is present.**

Configuration>  
RIO safety devices

**RIO PH T1  
RIO PH T2**

Deactivated (Default)

P1 = Reopen while closing.  
 P2 = Reclose while opening.  
 P3 = Partial stop. Only with [Automatic close] activated.  
 P4 = Obstacle standby.  
 P13 = Reopening during closure with immediate stop once the obstacle has been removed, even with the gate not in motion.

## Photocell BUS <n>

Associate a function with the photocell BUS <n> input.

 <n> is between 1 and 8 and corresponds to the address set on the photocell dip-switch

 The function only appears if there is a BUS photocell connected.

Configuration> BUS Devices	<b>BUS Photocell 1</b> <b>Photocell BUS 2</b> <b>Photocell BUS 3</b> <b>Photocell BUS 4</b> <b>Photocell BUS 5</b> <b>Photocell BUS 6</b> <b>Photocell BUS 7</b> <b>Photocell BUS 8</b>	Deactivated (Default) C1 = Reopen while closing (photocells) C2 = Reclose while opening (photocells) C3 = Partial stop Only with [Automatic close] activated. C4 = Obstacle standby (photocells) C13 = Reopen while closing, with immediate closure once the obstruction has been removed, even if the gate is not in motion Open Close
-------------------------------	--	--

## BUS <n> key selector

Associate a function with the input BUS <n> key selector. Different functions can be set according to the key turning direction.

 <n> is between 1 and 7 and corresponds to the address set on the key selector dip switch

 The function only appears if there is a BUS key selector connected.

Configuration> BUS Devices	<b>BUS 1 key selector</b> <b>BUS 2 key selector</b> <b>BUS 3 key selector</b> <b>BUS 4 key selector</b> <b>BUS 5 key selector</b> <b>BUS 6 key selector</b> <b>BUS 7 key selector</b>	Key to the right Key to the left  Choose the command to associate with the key movement.  Step-by-step - The first command is to open and the second to close. Sequential - The first command is to open, the second to STOP, the third to close and the fourth to STOP. Open Close Partial opening Stop B1-B2 output BUS 1 module relay - Activate output 2 (relay output) on BUS 1 I/O module BUS 2 module relay - Activate output 2 (relay output) on BUS 2 I/O module
-------------------------------	---	--

### I/O module - Inputs

Associate a function to the I/O module <n> inputs.

 <n> is between 1 and 2 and corresponds to the address set on the module dip switch.

 The function only appears if there is a BUS I/O module connected.

<p>Configuration&gt;          BUS Devices&gt;          I/O module BUS 1          I/O module BUS 2</p>	<p>input I1          input I2</p>	<p>Deactivated (Default)          Stop = Stop the gate and exclude automatic closing. Use a control device to resume movement.   If it is activated, the input is used as a normally closed contact.          r7 = Reopen while closing (sensitive edge with 8K2 resistor)          r8 = Reclose while opening (sensitive edge with 8K2 resistor)          Partial opening          Open          Close          Step-by-step - The first command is to open and the second to close.          Sequential - The first command is to open, the second to STOP, the third to close and the fourth to STOP.</p>
---	---------------------------------------	---

### I/O module <n> - Light output

Associate a function to the I/O module <n> input 1.

 <n> is between 1 and 2 and corresponds to the address set on the module dip switch.

 The function only appears if there is a BUS I/O module connected.

<p>Configuration&gt;          BUS Devices&gt;          I/O module BUS 1          I/O module BUS 2</p>	<p>Light output</p>	<p>Passage-open warning light - It notifies the user of the operator status.          Cycle lamp - The lamp stays on during the manoeuvre.          Courtesy light - The light switches on when a manoeuvre starts and remains on once the manoeuvre has finished, for the time set under the [Courtesy time] function.</p>
---	---------------------	---

### I/O module <n> - Relay output

Associate a function to the I/O module <n> input 2.

 <n> is between 1 and 2 and corresponds to the address set on the module dip switch.

 The function only appears if there is a BUS I/O module connected.

<p>Configuration&gt;          BUS Devices&gt;          I/O module BUS 1          I/O module BUS 2</p>	<p>Relay output</p>	<p>Bistable          Monostable - on from 1 to 180 seconds (Default 1)</p>
---	---------------------	--

### <Opening colour> BUS flashing beacon

Set the BUS flashing beacon colour during operator opening.

 **The function only appears if there is a BUS flashing beacon connected.**

Configuration> BUS Devices> BUS flashing beacon	<b>Opening colour</b>	White Yellow Orange Red (Default) Purple Blue Light blue Green
---	-----------------------	---

### <Closing colour> BUS flashing beacon

Set the BUS flashing beacon colour during operator closing.

 **The function only appears if there is a BUS flashing beacon connected.**

Configuration> BUS Devices> BUS flashing beacon	<b>Closing colour</b>	White Yellow Orange Red (Default) Purple Blue Light blue Green
---	-----------------------	---

### BUS flashing beacon <Automatic closing time colour>

Set the BUS flashing beacon colour during the automatic closing time.

 **The function only appears if there is a BUS flashing beacon connected.**

Configuration> BUS Devices> BUS flashing beacon	<b>Auto. cl. colour</b>	Off White Yellow Orange Red Purple Blue Light blue Green (Default)
---	-------------------------	--

### <Pre-flashing colour> BUS flashing beacon

On the BUS flashing beacon, set the flash colour for before opening and closing manoeuvres (pre-flash).

 **The function only appears if there is a BUS flashing beacon connected.**

Configuration> BUS Devices> BUS flashing beacon	<b>Pre-flashing colour</b>	White (Default) Yellow Orange Red Purple Blue Light blue Green
---	----------------------------	---

### <Signal error> BUS flashing beacon

Set the colour of the BUS flashing beacon in the event of an error signal.

 **The warning light is activated after sending a command for movement.**

 **The function only appears if there is a BUS flashing beacon connected.**

Configuration> BUS Devices> BUS flashing beacon	<b>Signal error</b>	Deactivated (Default) White Yellow Orange Red Purple Blue Light blue Green
---	---------------------	--

### Signal maintenance

Set the colour of the flash on enabled BUS devices (flashing beacons and selectors) when maintenance is necessary. With the function activated, these devices will signal that maintenance needs to be carried out at the start of each manoeuvre.

 **Configure maintenance and set the number of manoeuvres. See function [Configure maintenance].**

 **The function only appears if there is a BUS flashing beacon or a BUS selector connected.**

Configuration> BUS Devices> BUS device lights	<b>Signal maintenance</b>	Deactivation (Default) White Yellow Orange Red Purple Blue Light blue Green
---	---------------------------	---

## Command 2-7

Associate a command to the connected device on 2-7.

Configuration> Command inputs	<b>Command 2-7</b>	Step-by-step (Default) - The first command is to open and the second to close.  Sequential - The first command is to open, the second to STOP, the third to close and the fourth to STOP.
----------------------------------	--------------------	---

## Lock

Associate the electric lock/electromagnet release with a command.

Configuration> Functions	<b>Lock</b>	Deactivated (Default) From closed From open From open and closed Continue Electromagnet 24 V  <b>The electromagnet activates when the motor is stationary and deactivates during a manoeuvre.</b>
-----------------------------	-------------	--

## Closing thrust

When the leaves reach the closing limit-switch, the operator thrusts them towards the strike plate for a second.

Configuration> Functions	<b>Closing thrust</b>	Deactivated (Default) Minimum Medium Maximum
-----------------------------	-----------------------	---

## Thrust

Before every opening or closing manoeuvre, the leaves thrust inwards to release the electric lock.

 **The thrust motion is performed during opening or closing, depending on where the electric lock is active. See Function [Lock].**

Configuration> Functions	<b>Thrust</b>	Deactivated (Default) On
-----------------------------	---------------	-----------------------------

## Removing obstacles

If the function is active, when the operator detects an obstacle via the AST control on the control board or via the sensitive edge, the leaf movement inverts to create the space required to free the obstacle and then stops.

Configuration> Functions	<b>Removing obstacles</b>	Deactivated (Default) On
-----------------------------	---------------------------	-----------------------------

## B1-B2 output

Configure the contact.

Configuration> Functions	<b>B1-B2 output</b>	Bistable Monostable: on from 1 to 180 seconds (Default 1)
-----------------------------	---------------------	--

### Hold-to-run

With the function active, the operator stops moving (opening or closing) when the control device is released.

 **When the function is active, it excludes all other control devices.**

Configuration> Functions	<b>Hold-to-run</b>	Deactivated (Default) On
-----------------------------	--------------------	-----------------------------

### Obstacle with motor stopped

With the function active, the operator remains stopped if the safety devices detect an obstacle. The function is active when the gate is closed, open or after a complete stop.

Configuration> Functions	<b>Obst. with motor stopped</b>	Deactivated (Default) On
-----------------------------	---------------------------------	-----------------------------

### Automatic closure

Set the time before automatic closure, once the opening travel end point has been reached or once the photocells have caused a partial stop [C3].

 **The function does not work if any of the safety devices are triggered when an obstacle is detected, after a complete stop, during a power outage or if there is an error.**

Configuration> Times	<b>Automatic close</b>	Deactivated (Default) From 1 to 180 seconds
-------------------------	------------------------	--

### Automatic closing after either partial or pedestrian opening

Set the time before automatic closure after a partial opening command.

 **The function does not work if any of the safety devices are triggered when an obstacle is detected, after a complete stop, during a power outage or if there is an error.**

Configuration> Times	<b>Automatic partial close</b>	Off 1 to 180 seconds (Default 10)
-------------------------	--------------------------------	--------------------------------------

### Apartment building mode

With the Partial Opening command (2-3P), the leaf M2 opens.

If an Open command (2-3) is then sent, both leaves open.

With the [Automatic closing] function set, leaf M1 closes after the selected automatic closing time, while leaf M2 moves to the partial opening point set under [Partial opening adjustment].

 **If the partial opening command is given from input (2-3P), the [Automatic closing after either partial or pedestrian opening] function must be deactivated.**

 **To return to normal gate operation, send a closing command.**

 **If the partial opening command is sent via a timer, after the set time the operator returns to normal operation and the leaves close. See function [Create timer].**

### M1 opening delay time

Adjust the delayed opening of the first leaf compared to the second.

 **For motors with encoders only: if the distance between the two leaves is already sufficient to guarantee the delay time set, the delay will not be performed.**

 **The function does not appear with EM4024 motors [Motor type function set to EM4024].**

Configuration> Times	<b>M1 open delay</b>	Off 1 to 10 seconds (Default 2)
-------------------------	----------------------	------------------------------------

## M2 closing delay time

Adjust the delayed opening of the second leaf compared to the first.

 For motors with encoders only: if the distance between the two leaves is already sufficient to guarantee the delay time set, the delay will not be performed.

 The function does not appear with EM4024 motors [Motor type function set to EM4024].

Configuration> Times	M2 close delay	Off 1 to 25 seconds (Default 2)
-------------------------	----------------	------------------------------------

## Passage-open warning light

It notifies the user of the operator status.

Configuration> Manage lights	Passage-open warning light	Warning light on (Default) - The warning light stays on when the gate is moving or open.  Warning light flashing - The warning light flashes every half second when the gate is opening and stays on when the gate is open. The light flashes every second when the gate is closing, and remains off when the gate is closed.
---------------------------------	----------------------------	---

## Additional light

Choose the operating mode for the lighting device connected to output E3.

Configuration> Manage lights	Light E3	Disabled (Default) Cycle lamp - The lamp stays on during the manoeuvre.  The light remains off if an automatic closing time is not set.  Courtesy light - The light switches on when a manoeuvre starts and remains on once the manoeuvre has finished, for the time set under the function [Courtesy time].
---------------------------------	----------	---

## Courtesy time

Define how many seconds the additional light (set up as courtesy light) stays on after an opening or closing manoeuvre.

Configuration> Manage lights	Courtesy time	60 to 180 seconds (Default 60)
---------------------------------	---------------	--------------------------------

## Pre-flashing time

Adjust the time for which the beacon is activated before each manoeuvre.

Configuration> Manage lights	Pre-flashing time	Deactivated (Default) 1 to 10 seconds
---------------------------------	-------------------	--



### CRP address

Assign a unique identification code (CRP address) to the control board.

 **The function is used where there are multiple operators connected to the same communication BUS using the CRP protocol.**

Configuration> RSE communication	CRP address	1 to 254 (Default 1)
-------------------------------------	-------------	----------------------

### RSE speed

Set the communication speed of the remote connection system.

Configuration> RSE communication	RSE speed	4800 bps 9600 bps 14400 bps 19200 bps 38400 bps (Default) 57600 bps 115200 bps
-------------------------------------	-----------	--

### Save data

Save user data, timings and configurations to the memory device (memory roll).

 **The function is displayed only when a memory roll card is inserted into the control board.**

Configuration> External memory	Save data	
-----------------------------------	-----------	--

### Read data

Upload user data, timings and configurations to the memory device (memory roll).

 **The function is displayed only when a memory roll card is inserted into the control board.**

Configuration> External memory	Read data	
-----------------------------------	-----------	--

### Parameter reset

Restore the factory configurations except for: [users], [timers], [no. motors], [motor type], [CRP address], [limit-switch inputs function], [RSE speed], [password], [language], [time format] and the settings related to the travel calibration.

Configuration	Parameter reset	Confirm? NO Confirm? YES
---------------	-----------------	-----------------------------

### Guided procedure (Wizard)

You can use the system configuration wizard.

Configuration	Guided procedure (Wizard)	
---------------	---------------------------	--

## New user

Register up to a maximum of 1000 users and assign a function to each one.

 **The operation can be carried out by using a transmitter or a BUS selector device (e.g. a keypad or transponder reader). The board that manages the transmitters (AF) must be inserted into the connector.**

<b>Manage users</b>	<b>New user</b>	Choose the function to be assigned to the user.  Step-by-step - The first command is to open and the second to close. Sequential The first command is to open, the second to STOP, the third to close and the fourth to STOP. Open Partial opening B1-B2 output BUS 1 module relay - Activate output 2 (relay output) on BUS 1 I/O module BUS 2 module relay - Activate output 2 (relay output) on BUS 2 I/O module  Press ENTER to confirm. You will be asked to enter your user code. Send the code from the control device. Repeat the procedure to add other users.
---------------------	-----------------	--

## Remove user

Remove one of the registered users.

<b>Manage users</b>	<b>Remove user</b>	Use the arrows to choose the number associated with the user you want to remove.  <b>Alternatively, you can select a user by sending a command from the associated device.</b>  Press ENTER to confirm Confirm? NO Confirm? YES
---------------------	--------------------	---

## Remove all

Remove all registered users.

<b>Manage users</b>	<b>Remove all</b>	Confirm? NO Confirm? YES
---------------------	-------------------	-----------------------------

## Radio decoding

Choose the type of radio coding for the transmitters enabled to control the operator.

 **If you choose the type of radio coding for the transmitters [Rolling code] or [TW key block], any transmitters saved previously will be deleted.**

Manage users	Radio decoding	All decoding (Default) Rolling code TW Key block  Confirm? NO Confirm? YES
--------------	----------------	---

## Self-Learning Rolling

Save a new rolling code transmitter by activating acquisition from a rolling code transmitter that has already been saved. The saving and acquisition procedures are explained in the transmitter manual.

Manage users	Self-Learning Rolling	Deactivated (Default) On
--------------	-----------------------	-----------------------------

## Change mode

Change the function assigned to a specific user.

Manage users	Change mode	Use the arrows to choose the number associated with the user to be changed.  <b>Alternatively, you can select a user by sending a command from the associated device.</b> Press ENTER to confirm.  Choose the command to associate with the user.  Step-by-step - The first command is to open and the second to close. Sequential - The first command is to open, the second to STOP, the third to close and the fourth to STOP. Open Partial opening B1-B2 output BUS 1 module relay - Activate output 2 (relay output) on BUS 1 I/O module BUS 2 module relay - Activate output 2 (relay output) on BUS 2 I/O module  Press ENTER to confirm.  Confirm? NO Confirm? YES
--------------	-------------	--

## FW version

Display the firmware version and the GUI installed.

Information	<b>FW version</b>	Use the < > arrows to show: FW MC.x.x.xx (motor board firmware version) FW UI.x.x.xx (display board firmware version) GUI x.x (graphics)
-------------	-------------------	---

## BUS device status

Show the status of all devices that can be connected to the BUS and managed by the firmware in use.

### Key

<n> is the device number.

Information	<b>BUS device status</b>	<p>BUS photocells &lt;n&gt;  &lt;n&gt; from 1 to 8</p> <p><b>The status shown may be:</b></p> <p><b>OK</b></p> <p><b>Not communicating</b></p> <p><b>Safety device active</b></p> <p><b>BUS address conflict</b></p> <p>BUS selector &lt;n&gt;  &lt;n&gt; from 1 to 7</p> <p><b>The status shown may be:</b></p> <p><b>OK</b></p> <p><b>Not communicating</b></p> <p><b>BUS address conflict</b></p> <p>BUS flashing beacon &lt;n&gt;  &lt;n&gt; from 1 to 2</p> <p><b>The status shown may be:</b></p> <p><b>OK</b></p> <p><b>Not communicating</b></p> <p><b>BUS address conflict</b></p> <p>I/O module BUS &lt;n&gt;  &lt;n&gt; from 1 to 2</p> <p> <b>The status shown may be:</b></p> <p><b>OK</b></p> <p><b>Not communicating</b></p> <p><b>BUS address conflict</b></p>
-------------	--------------------------	---

### Manoeuvre counter

View the number of total or partial operator manoeuvres (after maintenance).

 **The number of manoeuvres is the number shown multiplied by 100.**

Information	Manoeuvre counter	Total manoeuvres - Manoeuvres performed since the operator was installed.  Partial manoeuvres - Manoeuvres carried out after the last maintenance.
-------------	-------------------	--

### Configure maintenance

Set the number of manoeuvres the operator can perform before a maintenance warning signal is generated.

 **The warning is displayed as an [Maintenance required] message and signalled by 3 + 3 flashes every hour on the device connected to the 10-5 output.**

Information	Maintenance conf.	Deactivated (Default) from 1 x100 to 500 x100
-------------	-------------------	--

### Maintenance reset

Reset the number of partial manoeuvres.

Information	Maintenance reset	Confirm? NO Confirm? YES
-------------	-------------------	-----------------------------

### Errors list

View the last 8 errors detected. The error list can be deleted.

Information	Errors list	 Use the arrows to scroll through the list. To cancel the error list, select [Delete errors] Press ENTER to confirm.  Confirm? NO Confirm? YES
-------------	-------------	--

### Show clock

Enable the clock on the display.

Timer management	Show clock	
------------------	------------	--

### Set the clock

Set the date and time.

Timer management	Set the clock	Use the arrows and the Enter button to enter the desired values.
------------------	---------------	--

## Automatic DST

Enable automatic daylight saving time setting.

 **Valid in Central Europe only UTC+1.**

Timer management	<b>Automatic DST</b>	Deactivated (Default) On  Summer changeover: +1 hour on the last Sunday in March (change to daylight saving time). Winter changeover: -1 hour on the last Sunday in October (change to standard time).
------------------	----------------------	--

## Time format

Choose the clock display format.

Timer management	<b>Time format</b>	24-hour 12-hour
------------------	--------------------	--------------------

## Create new timer

Time one or more types of activation chosen from those available.

Timer management	<b>Create new timer</b>	Use the arrows to choose the desired command. Open Partial opening B1-B2 output Press ENTER to confirm.  Start time Use the arrows to set the function activation start time. Press ENTER to confirm.  End time Use the arrows to set the function activation end time. Press ENTER to confirm.  Days of the week Use the arrows to set the function activation days. Select days All week Press ENTER to confirm.
------------------	-------------------------	--

## Remove timer

Removes one of the saved timings.

Timer management	<b>Remove timer</b>	Use the arrows to choose the timing to be removed. 0 = [Opening] P = [Partial opening] B = [Output B1-B2] Press ENTER to confirm.
------------------	---------------------	---

## Language

Set the display language.

<b>Language</b>	Italiano (IT) English (EN) (Default) Français (FR) Deutsch (DE) Español (ES) Português (PT) Русский (RU) Polski (PL) Românesc (RO) Magyar (HU) Hrvatski (HR) Український (UA) Nederlands (NL)
-----------------	---

## Enable password

Set a 4-digit password. The password will be requested to anyone who wants to access the main menu.

 **This option only shows if a password has NOT been enabled.**

<b>Password</b>	<b>Enable password</b>	Use the arrows and the Enter button to dial the desired code. Enter the password again using the arrows and the Enter button to confirm.
-----------------	------------------------	---

## Remove password

Remove the password that protects access to the main menu.

 **This option only shows if a password has been enabled.**

<b>Password</b>	<b>Remove password</b>	Confirm? NO Confirm? YES
-----------------	------------------------	-----------------------------

## Change password

Change the password protecting access to the main menu.

 **This option only shows if a password has been enabled.**

<b>Password</b>	<b>Change password</b>	Use the arrows and the Enter button to dial the desired code. Enter the password again using the arrows and the Enter button to confirm.
-----------------	------------------------	---

## Forgotten password

If you lose the password, you will need to reset the board to its factory settings. See [Factory reset].

## Factory reset

To restore the electronic board data to factory settings:

Disconnect the control board from the power supply.

Press and hold the < and > buttons, then reconnect the control board to the power supply.

Continue to press and hold the < > buttons until [Factory reset] is displayed.

Select [Confirm YES].

Press ENTER to confirm.

**⚠ When you reset the control board, all saved users, set times, manoeuvre configurations and calibration operations are deleted.**

**⚠ When using a CAME KEY device, always update the board firmware to the latest version.**



## Import/export data

Save user data and system configuration data on a MEMORY ROLL card.

The stored data can be reused for another control board of the same type to carry across the same configuration.

**⚠ Before inserting and removing the MEMORY ROLL card, DISCONNECT THE MAINS POWER SUPPLY TO THE LINE.**

- 1 Insert the MEMORY ROLL card into the corresponding connector on the control board.
- 2 Press the "Enter" button to access programming.
- 3 Use the arrows to choose the desired function.

Configuration > External memory > **Save data**

Save user data, timings and configurations to the memory device (memory roll).







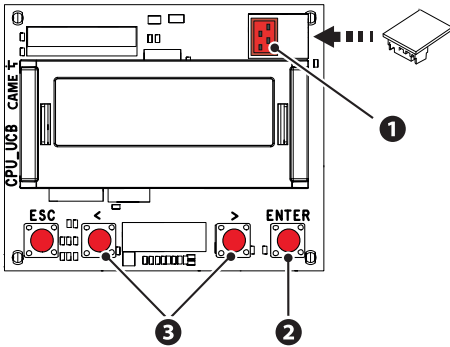







Configuration > External memory > **Read data**

Upload user data, timings and configurations to the memory device (memory roll).

 **Once the data have been saved and loaded, the MEMORY ROLL can be removed.**



## DISPLAY WARNINGS KEY

	The encoder is deactivated.
	The [Impact test] function is on.
	The operator detected an obstacle during closing.
	The operator detected an obstacle during opening.
	The operator detected two obstacles during closing.  <b>The number on the display varies according to the number of obstructions detected.</b>  <b>When the maximum number of detected obstructions has been reached, the operator stops and an error message shows on the display.</b>
	The operator detected two obstacles during opening.  <b>The number on the display varies according to the number of obstructions detected.</b>  <b>When the maximum number of detected obstructions has been reached, the operator stops and an error message shows on the display.</b>
	There is at least one programmed timer.
	A programmed timer is running.  <b>With the timer programmed for opening or partial opening, any given radio command will always allow opening. The wired commands continue to operate normally.</b>
<b>C&lt;n&gt;</b>	Wired safety device active  <b>The &lt;n&gt; value is associated with the selected parameter for the functions [CX input] [CY input] [CK input] [CZ input].</b>
<b>r7</b>	R7 safety device (sensitive edge) active
<b>r8</b>	R8 safety device (sensitive edge) active
<b>2r7</b>	R7 safety device (pair of sensitive edges) active
<b>2r8</b>	R8 safety device (pair of sensitive edges) active
<b>c&lt;n&gt;</b>	BUS photocell safety device active  <b>The &lt;n&gt; value is associated with the selected parameter for the [BUS photocell] functions.</b>

<b>c23</b>	Open command active for BUS photocells
<b>c24</b>	Close command active for BUS photocells
<b>C0</b>	Total stop active
<b>P&lt;n&gt;</b>	RIO safety device active  <b>The &lt;n&gt; value is associated with the selected parameter for the functions [RIO ED T1 - RIO ED T2] and [RIO PH T1 - RIO PH T2]</b>
<b>BUS address conflict</b>	ID conflict detected on BUS devices.
<b>Check BUS device</b>	No BUS device with a safety function configured.
<b>RIO not configured</b>	The RIO Conn board is not configured or has no safety configuration.
<b>Calibration needed</b>	Travel calibration required.
<b>wizard</b>	Select a motor type.
<b>Maintenance required</b>	Maintenance required (excl. encoder and manoeuvres exceeded for maintenance).
<b>OP</b>	Passage fully open
<b>CL</b>	Passage fully closed

## Error messages

<b>E1</b>	Motor M1 calibration error
<b>E2</b>	Motor M2 calibration error  With an EM4024 motor, E2 indicates a calibration error on M1 or M2.
<b>E3</b>	Encoder signal not detected error
<b>E4</b>	Service test failure error
<b>E7</b>	Operating time error
<b>E9</b>	Consecutive obstacles detected during closing
<b>E10</b>	Consecutive obstacles detected during opening
<b>E11</b>	Maximum number of obstacles
<b>E12</b>	Motor supply voltage missing or insufficient
<b>E13</b>	Limit switch input error or both limit switches open
<b>E15</b>	Incompatible transmitter error
<b>E17</b>	Wireless system communication error
<b>E18</b>	Wireless system not configured error
<b>E24</b>	Communication error or malfunction of a BUS safety device
<b>E25</b>	Address settings error on BUS devices

## FINAL OPERATIONS

 Before closing up the casing, check that the cable inlets are sealed to stop insects getting in and to prevent damp.

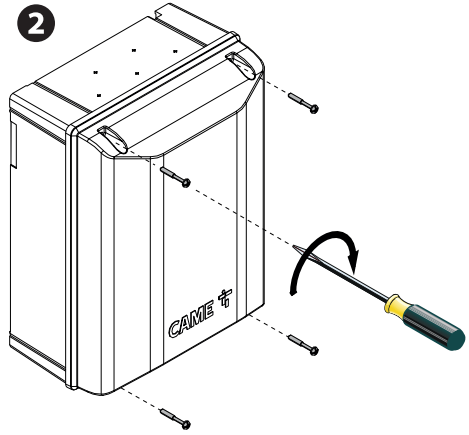
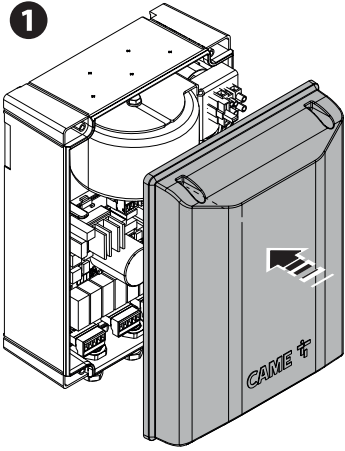







**CAME** 

**CAME.COM**

**CAME S.P.A.**

Via Martiri della Libertà, 15

31030 Dosson di Casier

Treviso – Italy

Tel. (+39) 0422 4940

Fax (+39) 0422 4941

info@came.com - www.came.com