



**GARD LS4**

**PERFORMANCE  
MEETS DESIGN**

**FOR PASSAGES UP TO 3,8 M**

**CAME** 

[CAME.COM](https://www.came.com)



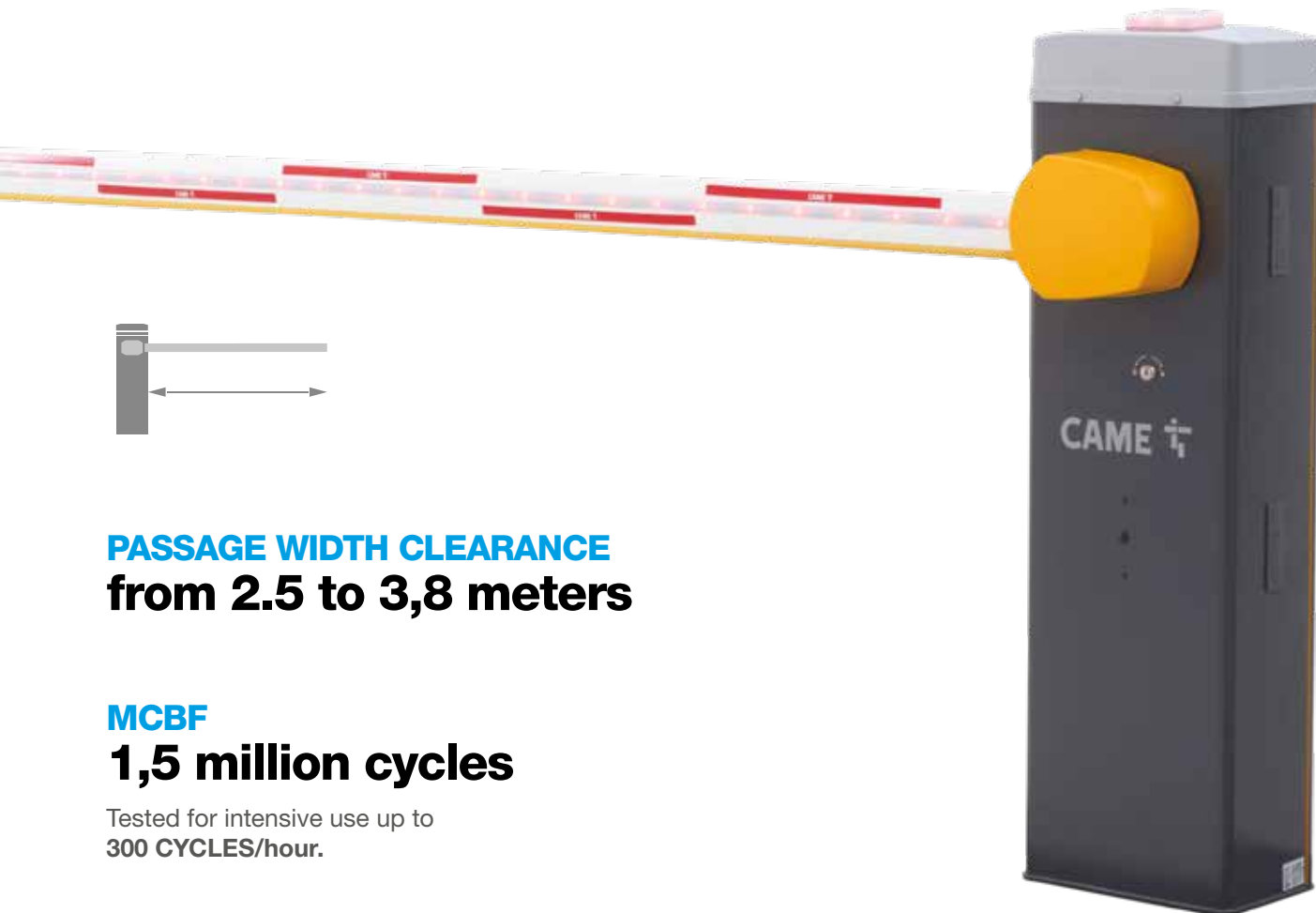

**PASSAGE WIDTH CLEARANCE**  
**from 2.5 to 3,8 meters**

**MCBF**  
**1,5 million cycles**

Tested for intensive use up to  
**300 CYCLES/hour.**

## **GARD LS4** **FEATURES**

### **RELIABLE**

thanks to the 24 V DC motor with ENCODER and ADVANCED SPEED CONTROL for monitoring the forces applied to the boom.

### **FAST AND EFFICIENT**

with maximum speed from 2 to 4 seconds depending on the length of the boom

### **ADVANCED ELECTRONIC**

developed with CONNECT technology and MODBUS protocol.

### **REFINED BOOM**

with integrable RG LED strip and shockproof rubber profile.

### **SAFE**

Compliant with EN 12453, it can easily pass the impact tests.

### **CUSTOMIZABLE FINISH**

Galvanized and painted steel Cabinet (RAL 7024) as standard, also available in AISI 304 stainless steel or any other RAL colour on request.



## ZL392-C CONTROL BOARD

The control board is placed directly under the upper cabinet cover. All the configuration and maintenance phases can therefore be carried out comfortably standing upright, with the cabinet closed, in total safety.

The advanced control board of Gard LS4, protected by an ABS cover, allows the installer to manage all setting through the graphic display as well as using the CONNECT SetUp App for smartphone or tablet.

Simply plugging the wireless interface CAME KEY in the dedicated slot, it is possible to carry configurations and calibrations easily and quickly.



## BATTERY-POWERED EMERGENCY SYSTEM

In the occurrence of a blackout or in any emergency situation where an electrical problem occurs, Gard LS4 is able to operate in complete safety thanks to an auxiliary battery power supply system (optional).

During normal operation with mains power supply, the system keeps the batteries fully charged in order to guarantee maximum reliability as soon as an emergency occurs.



## ADVANCED SPEED CONTROL

The modern 24V DC gearmotor equipped with Encoder implements an advanced speed management. Thanks to this innovative feature the movement is smooth and constant both when opening and when closing, without compromising the integrity of the mechanical system and the boom itself.

The control board continuously analyses the forces acting on the boom, adjusting the speed according to the parameters measured, guaranteeing durability and reliability in all climatic conditions.

## SAFETY BOOM RELEASE SYSTEM

CAME has developed a special system that minimizes damage in case of impact with the boom.

A high performance steel hinge allows the boom to disengage from the cabinet opening like a gate leaf, eliminating repair costs and recovery time.



## DOWNSIDE SKIRT

The folding aluminium skirt is available as 1721 mm modules, with rubber stopper and two connection brackets.

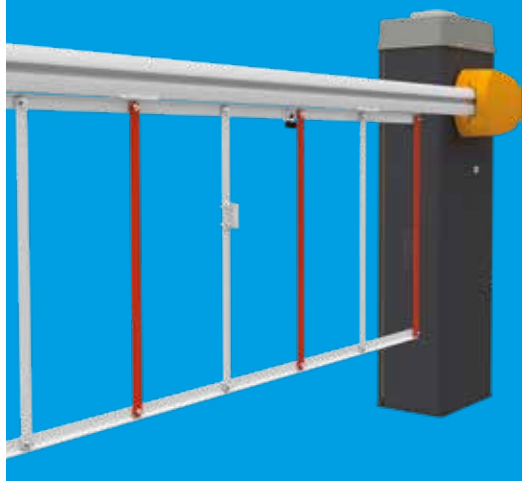



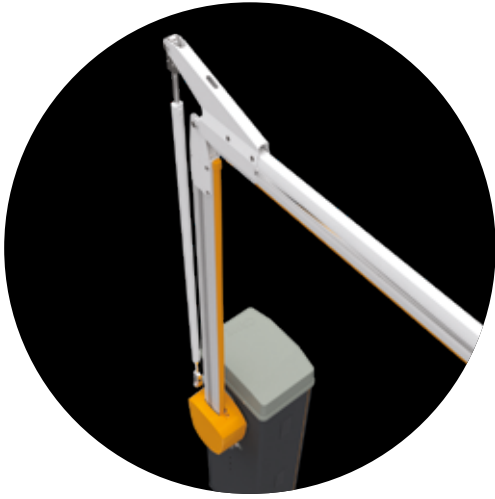

## ARTICULATED ARM

The articulated joint 803XA-0310 is the ideal solution for installations where there are height restrictions when the boom is fully open, such as in the presence of canopies or underground car parks.



## INTEGRABLE PHOTOCELLS

Photocells and control accessories, can be installed directly on the barrier cabinet, thanks to the prearranged housing.



## SINGLE BALANCING SPRING

CAME's R&D department has developed a practical variable balancing system, which allows using one single spring to be connected to the balancing lever at different predefined points.

It is therefore no longer necessary to have specific springs for the different boom lengths, but it is sufficient to operate on the hooking system.

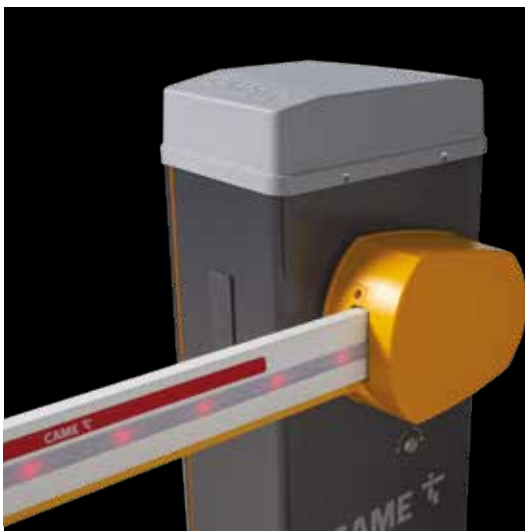

## RG LEDS

The LED strip system can be installed on both sides of the boom, and it regulates access acting as traffic light.

# KLT FLASHING LIGHT

The new KLT flashing light has been developed for adding safety signaling to GARD LS4. Its slim shape perfectly matches the cabinet upper cover lines. Together with the RG LED strip system on the boom, KLT is the perfect solution for any context where it is necessary to regulate the access acting as traffic light. However it is possible to use it as a standard single colour flashing light.

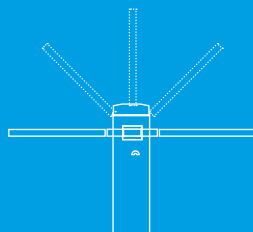
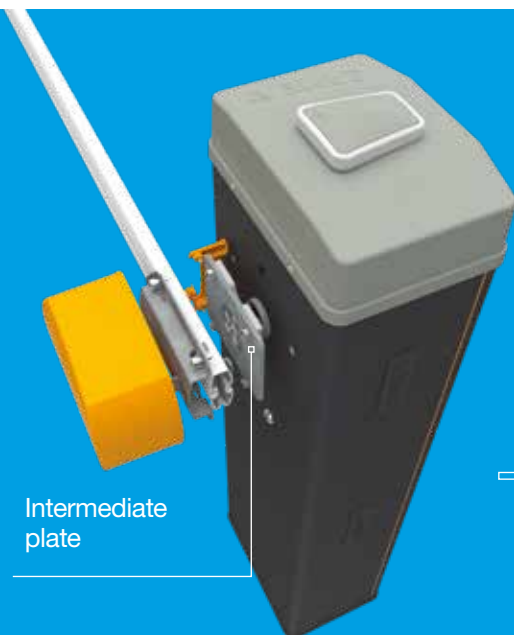
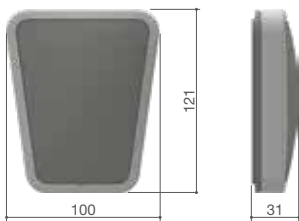
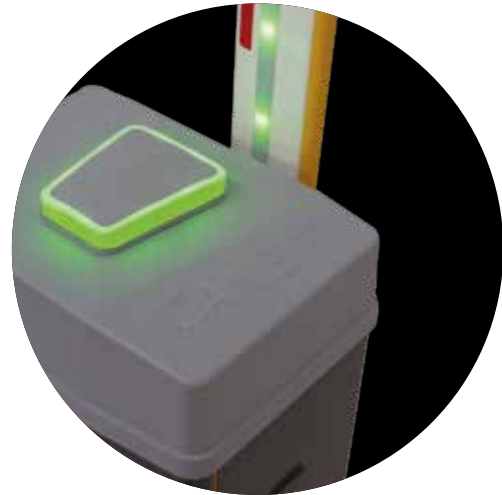

## EASY START-UP

Boom can be installed right or lefthand. Thanks to a dedicated intermediate plate, GARD LS4 allows installer to easily change the opening direction even after having installed the barrier, with no need for disassembling any component.

### Start it up in only three steps!

- 1 - Choose the opening direction
- 2 - Choose the boom length
- 3 - Run the first calibration

# BARRIER ACCESSORIES

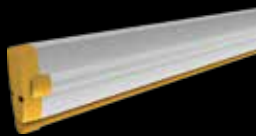

**803XA-0050**  
White painted aluminum boom, 90 x 35 mm, with groove cover-strip and shock-proof rubber profile. Length: 4050 mm.

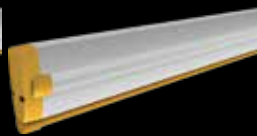

**803XA-0050**  
White painted aluminum boom, 90 x 35 mm, with groove cover strip and shock-proof rubber profile. Length: 3050 mm.



**001G0402**  
Tube section barrier made of white, painted aluminum. Ø 60 mm, boom length: 4.2 m.



**803XA-0570**  
Detachable boom attachment. After impact, the end of the detached boom rests onto the ground.



**803XA-0560**  
HD (Heavy Duty) joint for 90 x 35 mm boom.



**806LA-0060**  
Flashing lights.

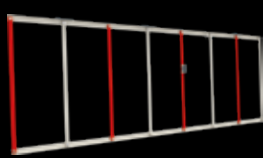

**803XA-0340**  
Painted aluminum skirt. 1720 mm module complete with junction brackets.



**803XA-0440**  
Swing rest - skirt support bracket.



**803XA-0330**  
Swing rest.



**001G02807**  
Fixed rest.



**803XA-0630**  
Heating system for operators installed in cold areas.



**803XA-0190**  
LED strips connection kit for HD jointed booms (Heavy Duty).



**803XA-0590**  
Fastening flange for 001G0402.



**001G0461**  
Package of 24 red, reflective, adhesive strips. (Only for 001G0402)

**001G02809**  
Package of 20 red, reflective, adhesive strips.



**803XA-0160**  
RG LED strips for booms up to 2-m long.



**803XA-0150**  
RG LED strips for booms up to 3-m long.



**803XA-0020**  
RG LED strips for booms up to 4-m long.



**803XA-0300**  
Auxiliary contacts unit for detecting the boom position.



**803XA-0290**  
Control card kit for operating during power outages and for recharging batteries, with battery housing.

## CONTROL BOARD

The ZL392-C features an innovative hi-tech firmware for movement control, which reduces all potential malfunctions, automatically managing the speed of the motor.

The firmware measures and adapts constantly the speed and the deceleration at each cycle thanks to the feed-back provided by the encoder.

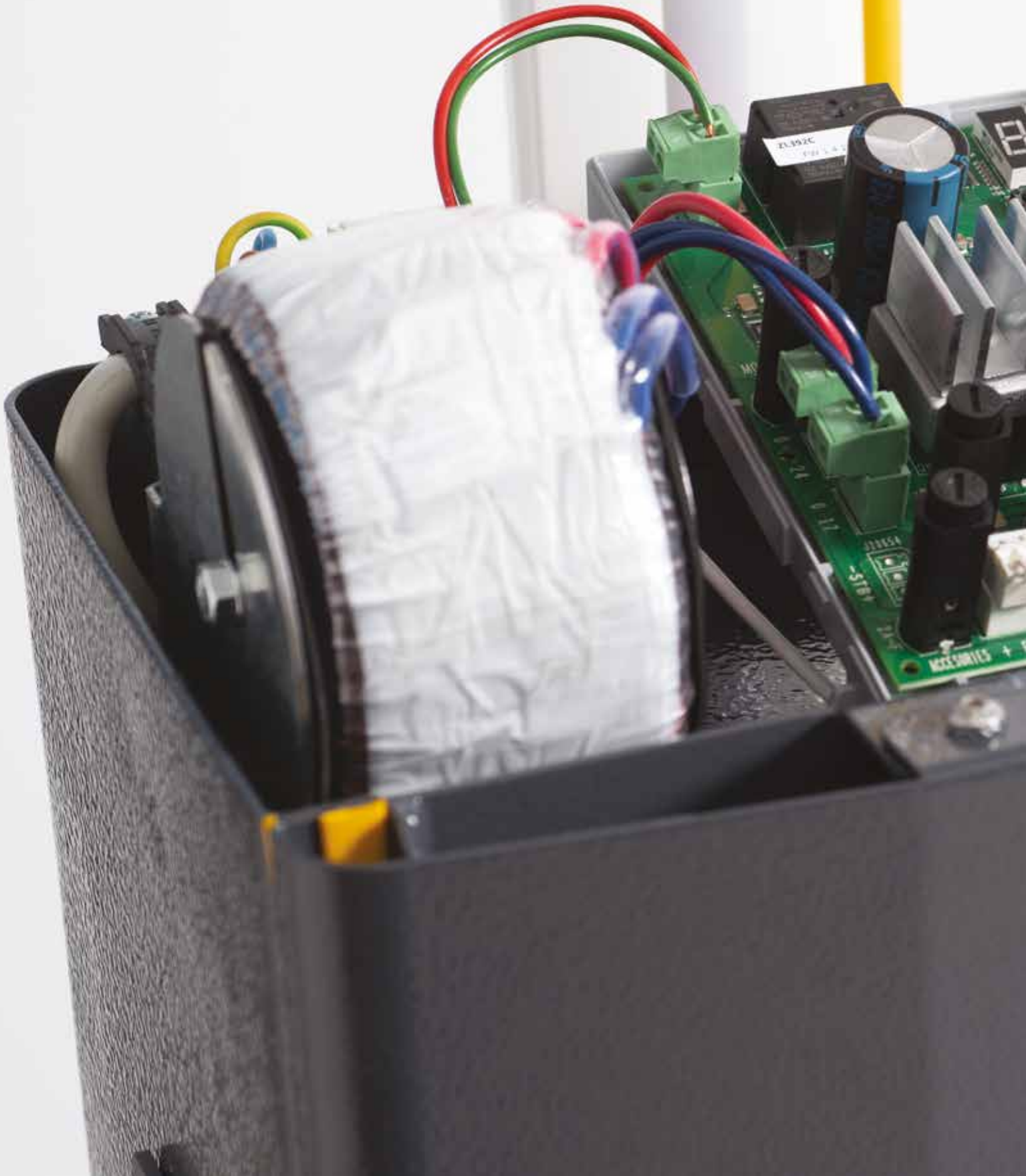



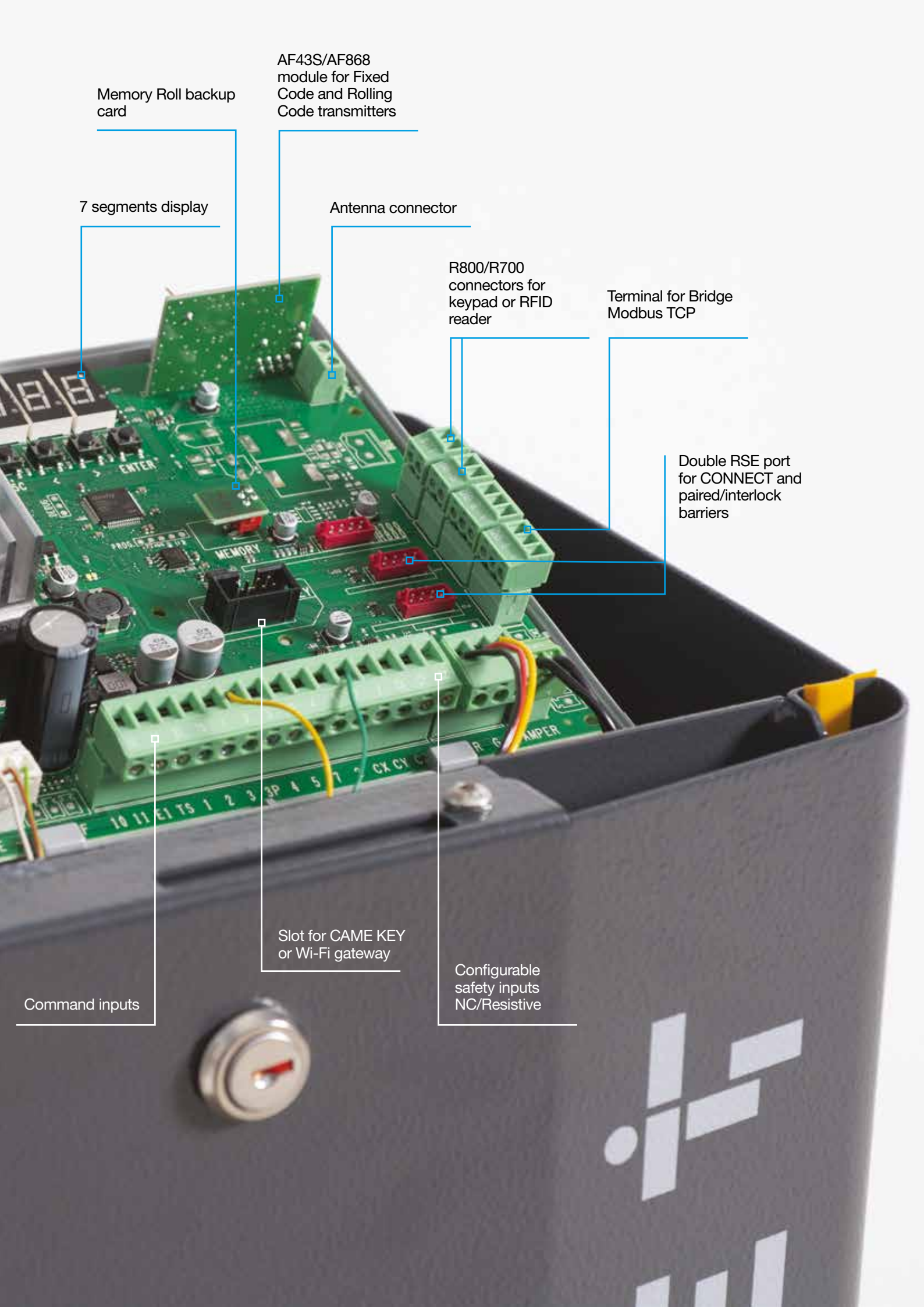

Memory Roll backup card

AF43S/AF868 module for Fixed Code and Rolling Code transmitters

7 segments display

Antenna connector

R800/R700 connectors for keypad or RFID reader

Terminal for Bridge Modbus TCP

Double RSE port for CONNECT and paired/interlock barriers

Slot for CAME KEY or Wi-Fi gateway

Configurable safety inputs NC/Resistive

Command inputs

# CONNECT

CONNECT is the CAME technology that makes it possible to manage automations capable of improving the quality of life. Automations connected via the Internet offer added value to the user and open up new horizons for the installer's business.

CAME has chosen to develop in-house the technologies required to manage data flow and protection. No external agency processes the information, no server is located in remote locations around the world. An innovative technological heart that guarantees reliability and high security. CAME has invested in research and development with the aim of simplifying the installer's work, improving user experience and offering new digital services.

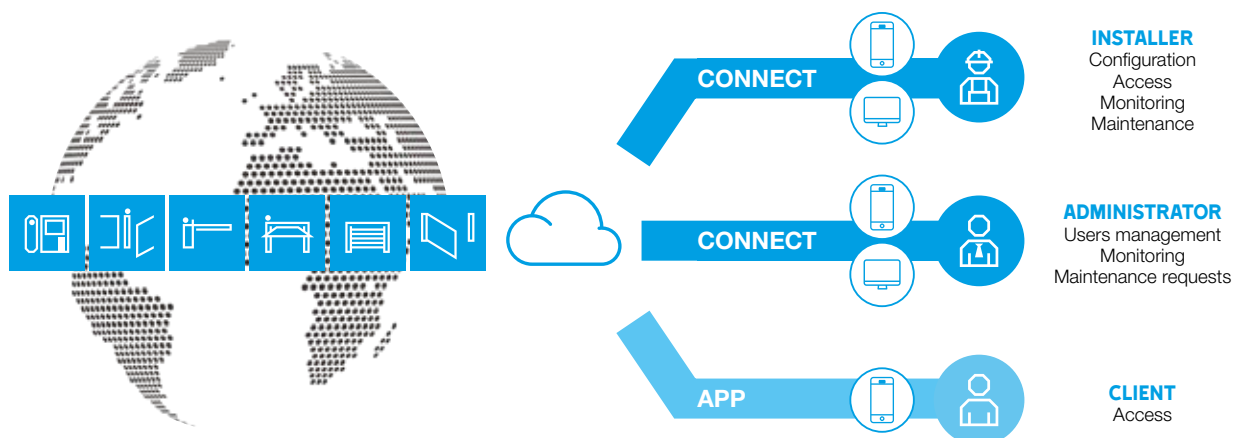

## CONNECT AT THE INSTALLER'S AND ADMINISTRATOR'S SERVICE

Connected automations can be managed remotely via PC or smartphone. The CONNECT platform enables automatic programming of transmitters, management of customers and systems installed, and monitoring of device status and scheduled maintenance. CONNECT allows the installer to offer a complete 24/7 service becoming the trusted partner for his customer.

## CONNECT AT THE CUSTOMER'S SERVICE

Through the free Apps that can be installed on any Android or iOS smartphone, the user can control the devices remotely. Compatible with Amazon Alexa devices, CAME automations can also be controlled by voice command.

## CONNECT MEANS

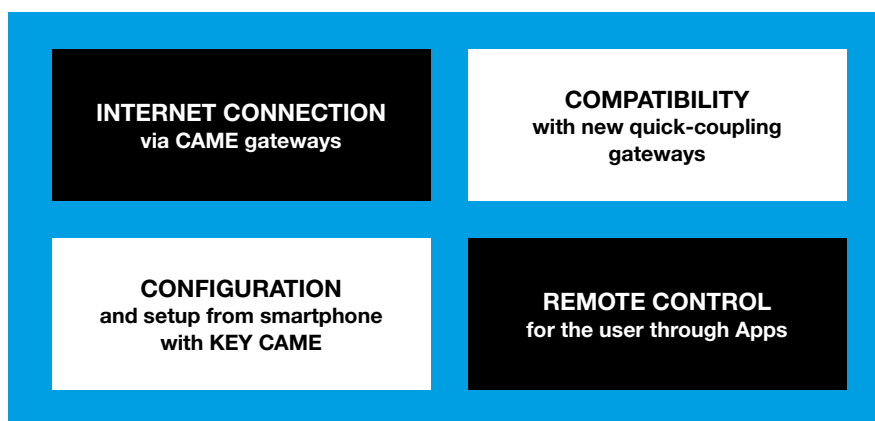

# CAME KEY

CAME.COM

## YOUR NEW WORK TOOL

CAME KEY makes all automation installation, programming and management steps easier and faster.

By exploiting the WiFi communication between CAME KEY and smartphones, the device serves as an interface between the control board and the CAME SetUp APP.

- Update firmware on the control board for new features.
- Manage all automation parameters, which are organized by type.
- Check maneuvers for scheduled maintenance.
- Management of radio controls and cards through QR code.
- Keypad codes configuration.



Smartphone Apps  
CONNECT SetUp



# QUALITY FOR CAME

## IS THE GUIDING PRINCIPLE OF EVERYTHING.

Gard LS4 is completely made in Italy and, like all CAME automation solutions, is the result of our smart production model that includes the digitization of each phase, integrating a complete series of tests on 100% of the products.

- Motor testing
- RPE Electrical safety and grounding
- Operator release tests
- Functional test for 60 seconds analyzing all functional parameters every 200 milliseconds
- Control board functional test
- Complete barrier system functional test



ENGINEERING

TESTING ONE BY ONE



PRODUCTION



Find out more on QUALITY INSIDE  
[www.came.com/qi](http://www.came.com/qi)

## DIMENSIONS (mm)

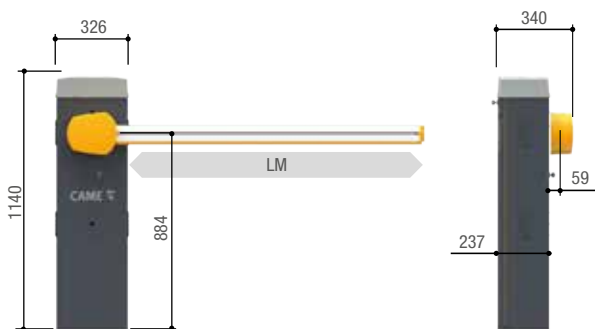

LM = Max. net clearance width 3,8 m

## THE COMPLETE RANGE

| CODE       | 230 V AC barriers with encoder and 24 V DC operator and built-in control panel  |
|------------|---|
| 803BB-0410 | GLS40AGS - Automatic barrier with irreversible 24 V DC operator with encoder; galvanized steel and painted cabinet with set up for fitting accessories. Balancing spring included. Power supply 220 - 230 V AC.                 |
| 803BB-0420 | GLS40RGS - Automatic barrier with irreversible 24 V DC operator with encoder; galvanized steel and painted cabinet with set up for fitting accessories. Balancing spring included. Power supply 120 V AC.                       |
| 803BB-0430 | GLS40ACS - Automatic barrier with irreversible 24 V DC operator with encoder; galvanized steel cabinet with customized RAL painting and set up for fitting accessories. Balancing spring included. Power supply 220 - 230 V AC. |
| 803BB-0440 | GLS40AX4 - Automatic barrier with irreversible 24 V DC operator with encoder; AISI 304 satin-finish steel cabinet with set up for fitting accessories. Balancing spring included. Power supply 220 - 230 V AC.                  |

## OPERATIONAL LIMITS

| MODELS                       | 803BB-0410 | 803BB-0420 | 803BB-0430 | 803BB-0440 |
|------------------------------|------------|------------|------------|------------|
| Max. net clearance width (m) | 3,8        | 3,8        | 3,8        | 3,8        |

● 24 V DC

## TECHNICAL CHARACTERISTICS

| MODELS                      | 803BB-0410                           | 803BB-0420                           | 803BB-0430                           | 803BB-0440                           |
|-----------------------------|--------------------------------------|--------------------------------------|--------------------------------------|--------------------------------------|
| Protection rating (IP)      | 54                                   | 54                                   | 54                                   | 54                                   |
| Power supply (V - 50/60 Hz) | 220 - 230 AC                         | 120 AC                               | 220 - 230 AC                         | 220 - 230 AC                         |
| Power supply to motor (V)   | 24 DC                                | 24 DC                                | 24 DC                                | 24 DC                                |
| Power (W)                   | 190                                  | 190                                  | 190                                  | 190                                  |
| Opening time at 90° (s)     | 2 ÷ 6                                | 2 ÷ 6                                | 2 ÷ 6                                | 2 ÷ 6                                |
| Cycles/Hour                 | 300                                  | 300                                  | 300                                  | 300                                  |
| Operating temperature (°C)  | -20 ÷ +55 (-40 with art. 803XA-0630) | -20 ÷ +55 (-40 with art. 803XA-0630) | -20 ÷ +55 (-40 with art. 803XA-0630) | -20 ÷ +55 (-40 with art. 803XA-0630) |
| RAL color                   | 7024                                 | 7024                                 | CUSTOMIZED                           | SATIN-FINISH                         |

● 24 V DC

© CAME SPA - KADENUDE22 - 2022 - EN  
CAME reserves the right to make any changes to this document at any time. Even partial reproduction is prohibited.

# CAME

**CAME S.P.A.**  
Via Martiri della Libertà, 15  
31030 Dosson di Casier  
Treviso - ITALY

We are a leading multinational supplier of integrated high-tech solutions for automating residential, public and urban settings, which generate intelligent spaces for the wellbeing of people.

- GATE AUTOMATIONS
- VIDEO DOOR ENTRY SYSTEMS
- AUTOMATIONS FOR GARAGES AND INDUSTRIAL DOORS
- AUTOMATIC BARRIERS
- PARKING SYSTEMS
- TURNSTILES AND SPEED GATES
- BOLLARDS AND ROAD BLOCKERS
- TEMPERATURE CONTROL DEVICES
- AUTOMATIC DOORS
- SOLUTIONS FOR AWNINGS AND BLINDS
- BURGLAR ALARM SYSTEMS
- HOME AUTOMATION SYSTEMS

CE

