

# VEHICLE ACCESS CONTROL SYSTEMS

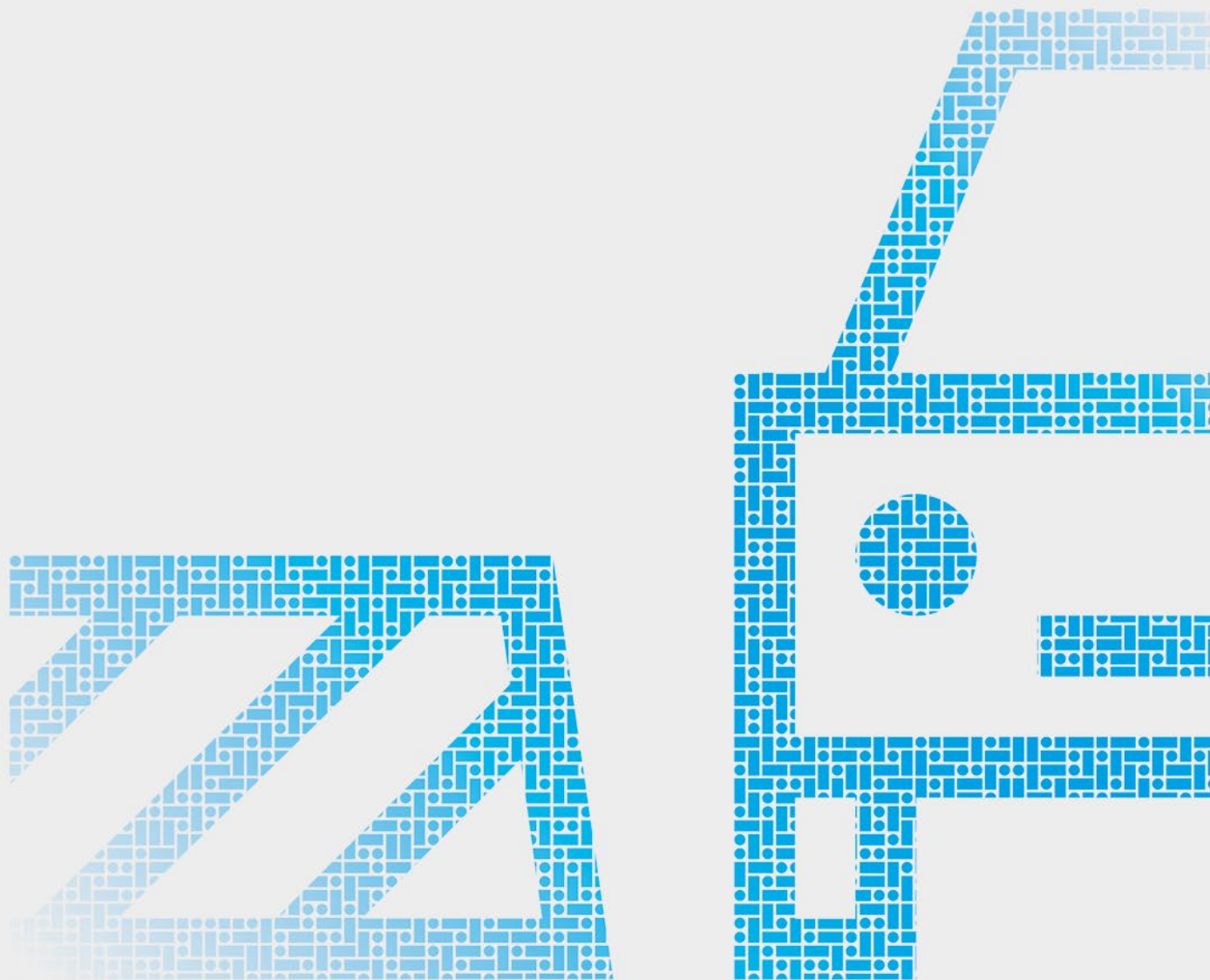

Road blocker and bollards



**CAME**   
**ÖZAK**

[CAME.COM](http://CAME.COM)

**CAME**  **ÖZAK**

# GENERAL INDEX

3	GENERAL INDEX
4	VISION
5	MISSION
6	WE'VE BEEN SPEAKING ABOUT QUALITY LIVING, IN ALL THE WORLD'S LANGUAGES, FOR 50 YEARS
7	THE CAME OFFER
8	OUR WORLDWIDE NETWORK
10	EXTENSIVE SOLUTIONS OVER 40 YEARS FOR SECURITY AND WELL-BEING OF THE PEOPLE AROUND THE GLOBE.
11	CAME ÖZAK TIMELINE
12	VIEWS FROM OUR FACILITY



## 15 ROAD BLOCKERS

### 20 DEEP EXCAVATED SERIES

20	HRB (ANTI TERROR / HEAVY DUTY MODEL)
26	RRB (REINFORCED MODEL)
30	RB (ACCESS CONTROL MODEL)
34	GENERAL TECHNICAL SPECIFICATIONS (DEEP EXCAVATED)

### 40 SHALLOW MOUNT SERIES

40	HRB SHLW (ANTI-TERROR / HEAVY DUTY - SHALLOW MOUNT MODEL)
44	RRB SHLW (REINFORCED - SHALLOW MOUNT MODEL)
48	RB SHLW (ACCESS CONTROL - SHALLOW MOUNT MODEL)
50	TRB (TRAFFIC REGULATION - SHALLOW MOUNT MODEL)
52	GENERAL TECHNICAL SPECIFICATIONS (SHALLOW MOUNT)



## 55 BOLLARDS

### 55 RETRACTABLE (HYDRAULIC) BOLLARDS

#### 62 DEEP EXCAVATED SERIES

62	HBD/12 (ANTI-TERROR / HEAVY DUTY - RETRACTABLE MODEL)
66	HBD/8 (ANTI-TERROR / HEAVY DUTY - RETRACTABLE MODEL)
70	RBD/4 (REINFORCED - RETRACTABLE MODEL)
76	TBD (TRAFFIC REGULATION - RETRACTABLE MODEL)
80	GENERAL TECHNICAL SPECIFICATIONS (RETRACTABLE MODELS)

### 81 FIXED (STATIC) BOLLARDS

#### 82 DEEP EXCAVATED SERIES

82	HBD/12 (ANTI-TERROR / HEAVY DUTY - FIXED MODEL)
83	HBD/8 (ANTI-TERROR / HEAVY DUTY - FIXED MODEL)
84	RBD/4 (REINFORCED - FIXED MODEL)

#### 85 SHALLOW MOUNT SERIES

86	HBD/12 SHLW (ANTI-TERROR / HEAVY DUTY - FIXED - SHALLOW MOUNT MODEL)
87	HBD/8 SHLW (ANTI-TERROR / HEAVY DUTY - FIXED - SHALLOW MOUNT MODEL)
90	RBD/4 SHLW (REINFORCED - FIXED - SHALLOW MOUNT MODEL)

#### 91 TRAFFIC REGULATION SERIES

92	TBD (TRAFFIC REGULATION - FIXED MODEL)
----	--

#### 93 REMOVABLE BOLLARDS

94	TBD RMB REMOVABLE BOLLARD
----	---------------------------

# VISION

## VISION

We believe in a world where sustainable technological innovation makes people's lives more comfortable, simple and secure





# MISSION

To create a global offer of high-quality technological products and solutions for automation, smart homes, access control and security to improve our customers lives and our partners business

**CAME**   
MORE THAN TECHNOLOGY



# WE'VE BEEN SPEAKING ABOUT QUALITY LIVING, IN ALL THE WORLD'S LANGUAGES, FOR 50 YEARS.

50<sup>TH</sup>  
ANNIVERSARY

CAME has catered to people's needs for 50 years by using technology as a key to a quality life. Every project drives our innovation and focus to make people's lives as comfortable as possible. CAME is a company where skills and experience come into play. Its know how blends functionality and design continuously improving performance.

You are sure that you can rely on professionals able to transform our innovations into solutions, to create customized automation proposals integrated with the best connectivity and mobility technologies. CAME and its partners, together, to satisfy its increasingly demanding and heterogeneous customers for their culture and needs, in order to transform living spaces into more intelligent and safe places.

**CAME** 

**CAME † BPT**

**CAME † URBACO**

**CAME † BTECH**

**CAME † ÖZAK**

**CAME † GO**

**CAME † PARKARE**

**CAME † KMS**

**CAME † NEPOS**

**CAME † ENTROTEC**

## ALWAYS ONE-STEP-AHEAD

CAME is a market-leading brand that makes integrated automation solutions, video-entry, access control and parking systems for the public and private sectors.

The CAME Group boasts a series of highly specialized companies. Together they cover a large share of their market. The group delivers cutting-edge solutions for the residential, business and urban segments. Whether its home automation or heating control, road barriers and high-security bollards, or automatic doors and sectional industrial doors, CAME Group is a key player.

Today CAME is set on one, distinct corporate vision, which makes the organization a cutting-edge technological partner.

# RESIDENTIAL SOLUTIONS



We have gone on to develop an idea of home automation that is increasingly integrated and connected with people's lives. Today, automation is at the heart of the home, managing entrances and garage doors, controlling blinds and shutters, video entry systems and climate control.



# BUSINESS SOLUTIONS



For every public area, we offer the most sophisticated systems for pedestrian and vehicle access control and security, video entry systems and parking solutions. Small and large companies, commercial enterprises, large buildings: CAME-branded automation provide control and safety in both small and large working environments.

# URBAN SOLUTIONS



The complexity involved in living spaces and in mobility flows require ever greater protection and security, plus enhanced reactive capacity and greater know-how. Our offer is geared to meet the different automation needs for urban planning and architectural scenarios. CAME solutions are engineered for managing safety and control in large works and for contributing to the planning of urban spaces making them "Safe and Smart", as called for in today's fast-paced, metropolitan centres.



# OUR WORLDWIDE NETWORK.

## We are a worldwide network.

From the Treviso head office, home to the group's thriving core, we coordinate 11 manufacturing plants and 10 R&D units. We have subsidiaries in 20 countries and, thanks to our commercial partner and distributors, we operate in 118 countries with an integrated and global vision.

We are the technology partner for those projects that require integrated systems for improving the quality of our living space – whether private or public. Our products are made for controlling homes, managing urban venues and workplaces, of any kind, anywhere in the world.

Our Group shares common goals, which go well beyond our respective specializations: thanks to the synergies that exist among all the divisions and brands, we share a modus operandi that enriches our diversity.

## BRANCHES AMERICA

Brazil  
Chile  
Mexico  
Perù  
USA



# 2000

OUR EMPLOYEES AROUND THE WORLD





**CAME HQ**  
Treviso, Italy



**BRANCHES  
EUROPE**

- |             |          |
|-------------|----------|
| Italy       | Poland   |
| Belgium     | Portugal |
| Croatia     | Russia   |
| France      | Spain    |
| Germany     | UK       |
| Ireland     | Turkey   |
| Netherlands |          |

**10**

R&D CENTRES

**20**

COUNTRIES WITH DIRECT BRANCHES

**118**

COUNTRIES WITH PARTNERS AND DISTRIBUTORS

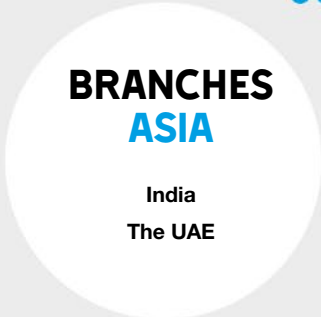

**BRANCHES  
ASIA**

- India
- The UAE

**11**

PRODUCTION PLANTS

- Dosson di Casier - Italy
- Sesto al Reghena - Italy
- Spilimbergo - Italy
- Hemel Hempstead - UK
- Entraigues - France
- Barcelona - Spain
- Kocaeli - Turkey



**480**

WORLDWIDE DISTRIBUTORS AND PARTNERS

# EXTENSIVE SOLUTIONS OVER 40 YEARS FOR SECURITY AND WELL-BEING OF THE PEOPLE AROUND THE GLOBE.



**CAME ÖZAK**, a global player, has incorporated one of the widest range of products offering solutions in pedestrian and vehicle access control fields. We owe our success to our talented designers and engineers along with our flexible manufacturing processes.

Understanding needs of the people, thus providing customised solutions tailored to expectations has made our offering a choice for numerous residential, governmental, urban and sports facilities. Our fully integratable, user friendly and high performance solutions are available with our solution partners all over the world.

**CAME**  **ÖZAK**

# TIMELINE

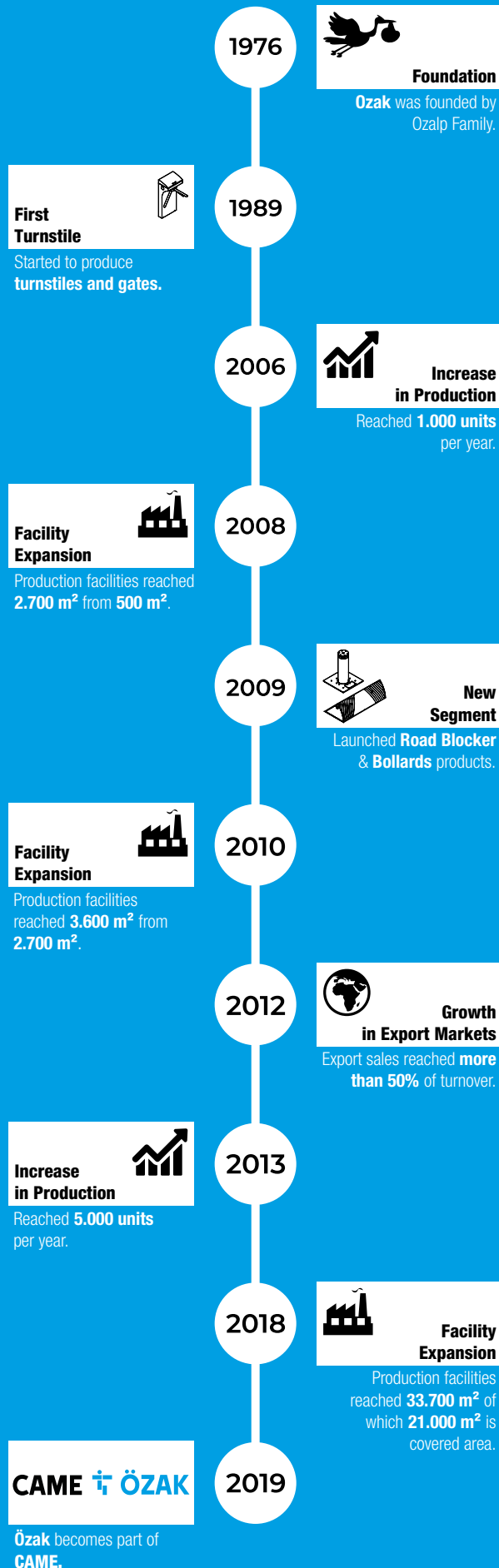



# VIEWS FROM OUR FACILITY

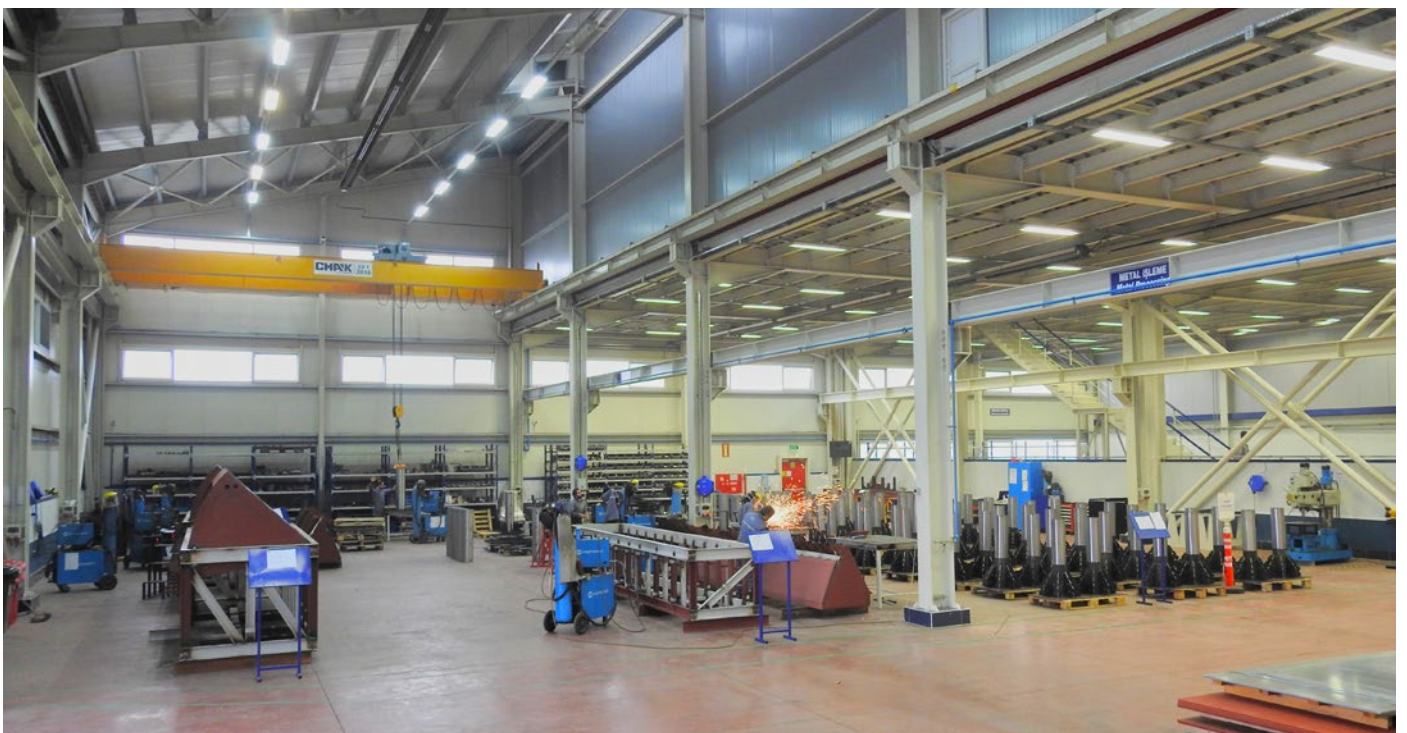
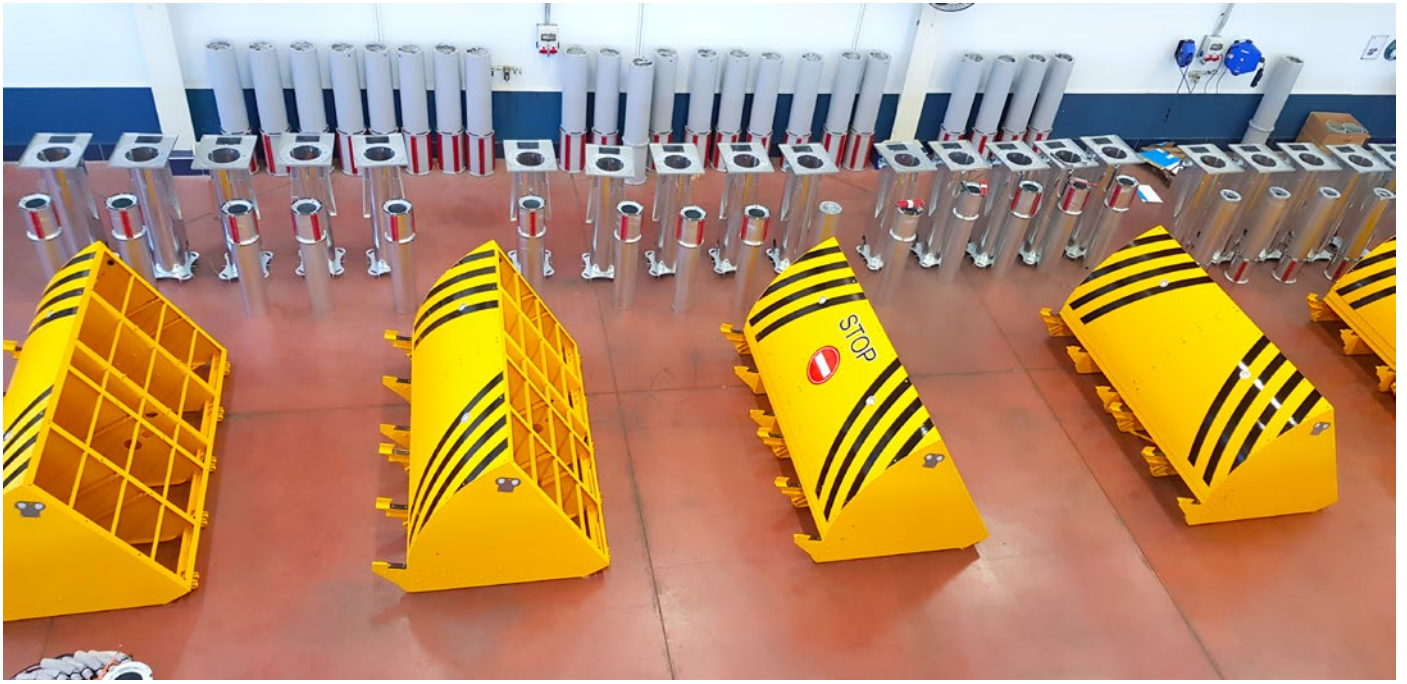





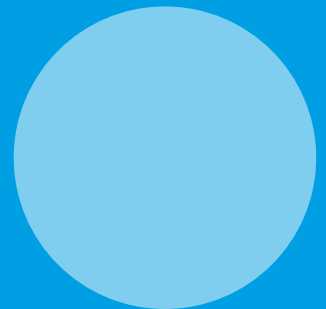
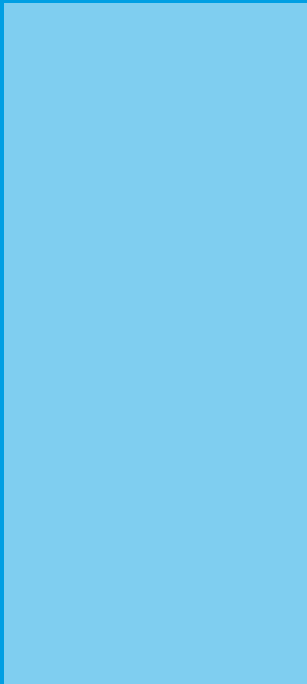

## ROAD BLOCKERS

### DEEP EXCAVATED SERIES

- 20 HRB (ANTI TERROR / HEAVY DUTY MODEL)
- 26 RRB (REINFORCED MODEL)
- 30 RB (ACCESS CONTROL MODEL)
- 34 GENERAL TECHNICAL SPECIFICATIONS (DEEP EXCAVATED)

### 40 SHALLOW MOUNT SERIES

- 40 HRB SHLW (ANTI-TERROR / HEAVY DUTY - SHALLOW MOUNT MODEL)
- 44 RRB SHLW (REINFORCED - SHALLOW MOUNT MODEL)
- 48 RB SHLW (ACCESS CONTROL - SHALLOW MOUNT MODEL)
- 50 TRB (TRAFFIC REGULATION - SHALLOW MOUNT MODEL)
- 52 GENERAL TECHNICAL SPECIFICATIONS (SHALLOW MOUNT)





قف  
STOP





**NATPET**

National Company for Petrochemical Industries



**ناتبيت**

الشركة الوطنية للصناعات البتروكيمياوية







قف  
STOP





# HRB ROAD BLOCKER

(Anti-terror / Heavy Duty Model)



**ASTM F2656  
M50 (K-12)**  
HRB30R90

**PAS 68 (N3)  
IWA 14 (N3C)  
ASTM F2656 (C750)**  
HRB30R110

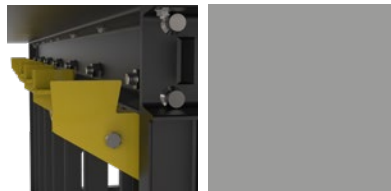

<b>Power</b>	Standard 380V AC 3-Phase 50/60 Hz, 2,2 - 11 kW motor (varies depending on blocker size). Operating with 24V DC in case of power failure is optionally available.
<b>Control Pack</b>	24V DC powered PLC control unit is placed in power unit cabinet. 24V DC (opt.12V DC / 220V AC) solenoids.
<b>Speed</b>	Standard operation ~3 - 5 sec. (ascend/descend) depending on road blocker dimensions. Fast raise up (EFO, by optional hydraulic accumulator) ~1 - 1,5 sec. and may differ depending on road blocker dimensions for road blockers wider than 4,0 m.
<b>IP Rating</b>	IP55 - Hydraulic Power Unit (optionally electronics control unit with IP67 protection box) IP68 - Hydraulic Piston
<b>Operating Temperature</b>	-5°C / +55°C (opt. -30°C / +70°C)
<b>Crash / Impact Rating</b>	Crash tested and certified according to IWA 14-1:2013 Road Blocker V/7200[N3C]/80, PAS68:2013 Road Blocker V/7500[N3]/80, and ASTM F2656-20 C750/7200 standards ( <b>HRB 30 R 110</b> ).

Crash tested and certified according to ASTM F2656-07 at M50 P1 (K-12) level (**HRB 30 R 90**) also designed and produced to withstand impacts mentioned below:

Standard	Vehicle Type	Weight	Speed
PAS 68	N3	7500 kg	80 km/h (50 mph)
IWA 14-1	N3C	7200 kg	80 km/h (50 mph)

(Please contact for applicable product dimensions)

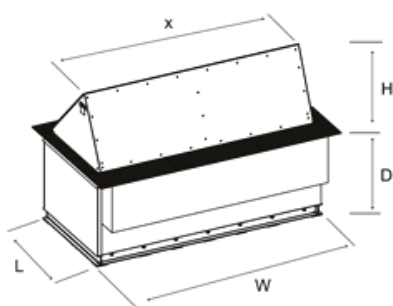

Product Code	Blocker Unit Width (X)	Nr. of Pistons	Raising Height 900 mm	Raising Height 1100 mm
			Dimensions (LxWxD)	Dimensions (LxWxD)
HRB 10R_	1000	1	1665 x 1170 x 1270	1945 x 1170 x 1450
HRB 15R_	1500	1	1665 x 1670 x 1270	1945 x 1670 x 1450
HRB 20R_	2000	1	1665 x 2170 x 1270	1945 x 2170 x 1450
HRB 25R_	2500	1	1665 x 2670 x 1270	1945 x 2670 x 1450
HRB 30R_	3000	1	1665 x 3170 x 1270	1945 x 3170 x 1450
HRB 35R_	3500	1	1665 x 3670 x 1270	1945 x 3670 x 1450
HRB 35R_	3500	2	1665 x 3670 x 1270	1945 x 3670 x 1450
HRB 40R_	4000	1	1665 x 4170 x 1270	1945 x 4170 x 1450
HRB 40R_	4000	2	1665 x 4170 x 1270	1945 x 4170 x 1450
HRB 45R_	4500	2	1665 x 4670 x 1270	1945 x 4670 x 1450
HRB 50R_	5000	2	1665 x 5170 x 1270	1945 x 5170 x 1450
HRB 55R_	5500	2	1665 x 5670 x 1270	1945 x 5670 x 1450
HRB 60R_	6000	2	1665 x 6170 x 1270	1945 x 6170 x 1450

\* Different raising heights are optionally available.

<b>Axle Load Resistance</b>	50 t
<b>Hydraulic Cylinder</b>	Dust sealed hydraulic cylinder, developed for heavy duty use.
<b>Unit</b>	1 - 4 m wide models contain single piston (opt. 3,5 and 4 m wide models contain double pistons). 4,5 - 6,0 m wide models contain double pistons. Contains safety valve for hose bursts.



## Hydraulic Power Unit and Cabinet

Strengthened industrial hydraulic pump.  
 40 - 120 lt capacity oil tank with magnetic metal collector and suction filter.  
 Built-in oil level indicator and sensor, oil temperature indicator and audio alarm feature for low oil level.  
 Standard 70 - 150 bar pressure (max. 180 bar).  
 10 m R2 type (double wire braided mesh) reinforced hydraulic hose.



Motor, hydraulic pump and solenoid valves are placed in an easily accessible galvanized and electrostatic powder coated steel cabinet with 2 built-in lock lids (opt. stainless steel cabinet).

Cabinet Type	Width (mm)	Length (mm)	Height (mm)
Cabinet 1	940	570	970
Cabinet 2	1040	590	1285
Cabinet 3	1243	840	1285

\*Suitable cabinet type is selected according to the preferred product configuration.

## System

Down, up, stop, emergency inputs and external sensor inputs/outputs (e.g. loop detector, safety sensor, traffic light, remote control, etc.).  
 System alerts with an audio signal during lowering and raising operation. A loud siren alert in case of alarm or emergency.  
 System stops in case of emergency as per default set-up and possible to be lowered or raised automatically (user's preference).  
 Can be lowered and raised manually in case of power failure or during maintenance with manual pump and manual valve feature.  
 Automatic raise up mode deploys (available with optional loop detector) the road blocker after the vehicle has passed over.  
 Sensor controlled stopping both at the top and bottom positions of the blocker unit.  
 Free standing piston connection structure that does not put any load on the piston during vehicle passage and in case of an impact.  
 Safety devices (if any, such as; safety sensor, loop detector, etc) are enabled in case fast raise up (EFO, optional) feature is activated and they can be optionally disabled.

## Blocker Unit (Underground Unit)

All parts are coloured with industrial paint with two components over anticorrosive primer application.  
 Body is structured and strengthened with U-shaped beams. Contains galvanised steel sleeve around main chassis.  
 Product is designed that no vehicle crashing effect can displace it after embedded or installed in to the ground.

## Blocker Unit (Impact Blocking Unit)

Top plates (vehicle pass through surface) are hot dip galvanised and electrostatic powder coated.  
 All other parts are coloured with industrial paint with two components over anticorrosive primer application.  
 Moving parts are colored with RAL 1003 yellow (impact surface yellow-black) and fixed road surface plates in RAL 9005 black. In addition, the impact surface is finished with reflective signs and warnings.  
 Bulge free hidden hinge structure below the ground level allows vehicles to pass over smoothly and quietly.  
 Impact blocking unit is made of special, reinforced, 6 mm thick, solid V-formed vertical impact load distributing panel construction assembled to the main chassis with 350 - 550 mm distance from each other. Each impact load distributing panel is supported with 4 pieces of 30 x 10 mm solid steel bars placed with equal distance from each other so that a strong steel construction has been designed.  
 Impacts are absorbed and blocked by impact load distributing panels together with 10 mm thick steel sheet attached to their V-formed front sides and specially formed hook type holders.  
 Frontal crash-facing section is furnished with a replaceable 3 mm thick round formed steel sheet to handle light impacts.  
 Resistance of 10 mm + 3 mm thick impact surfaces are increased with the constructive structure by vertical solid panels behind and the 30 x 10 mm solid steel bars.  
 Top panels where the vehicles pass over are made of 10 / 11 mm thick hot-dip galvanized steel with non-skid surface.  
 The road blocker moves up and down as a block supported by Ø50 mm steel hinges at pivot points, which are welded on the main frame with wedges for extra strength. Number of hinges varies according to blocker width (3 m wide blocker contains 7 pieces of hinges).  
 Impact blocker unit raises with 45° angle from the ground level and equipped with flashing indicators on side and front panels. A top lid integration is available for easy access to interior units for service and maintenance purposes.

## Control System

3 buttons for up, down and stop operations and 1 button for emergency stop are contained in a box that is suitable for outdoor use (optionally, 1 button for EFO-fast raise up).  
 System stops its movement with the command from safety sensor (opt.) and loop detectors (opt.).  
 Contains built-in LED indicators and 10 m cable.  
 The system works with PLC as standard.  
 Status of safety sensors (if any) and loop detectors (if any), position and movement of the blocker and low oil level situation of the system can be monitored with optional PLC with diagnostic display.  
 Compatible with any access control system (by third parties).



## Power-off Situation

Road Blocker remains in its position in case of power-off. Optionally; can be lowered or raised and lowered by battery pack with 24V DC motor. Battery pack provides min.100 movements (50 deploy + 50 retract) when fully charged.

## Optional Features and Accessories

Hydraulic accumulator for EFO-fast raise up (1 piston or 2 pistons systems), 24V DC motor in case of power failure (50 deploy + 50 retract), oil heater (for oil tank), oil cooler, heater for electronic components, submersible pump, traffic light (Ø200/300 mm, red-green LED, electrostatic powder coated over 304 grade stainless steel body), traffic light pole (electrostatic powder coated over hot dip galvanised steel), loop detector (double contact), safety sensors (with 50 cm height poles), IP67 box (for PLC, SMPS, connectors etc inside power unit), wireless remote control (receiver and transmitter), external buttons, hot dip galvanization, double effect hydraulic unit, double speed hydraulic unit, PLC with diagnostic display, different product dimensions.

## Installation

Installation with C30 grade concrete and steel rebar reinforcement. Ground levelling and preparation works shall be carried on before pouring the concrete. Allowable bearing value of the ground shall be minimum 1/2 kg/cm<sup>2</sup>, if not, works shall be carried on to fulfil. Installation shall be done according to the manufacturer's instructions.





**M50 P1 (K12)  
ASTM F2656-07**



for crash  
test video



**Max P1 Limit**

**Maximum Penetration**





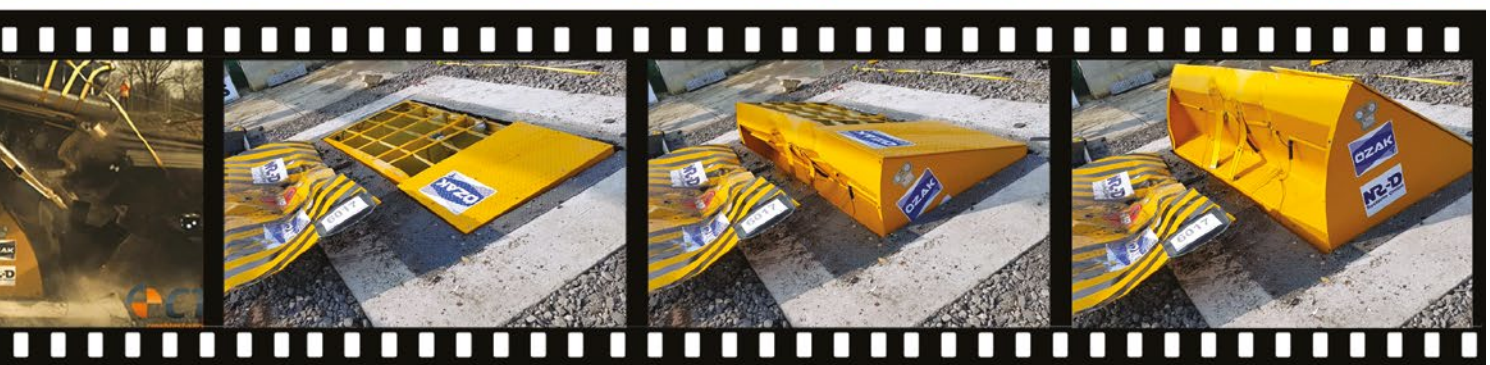
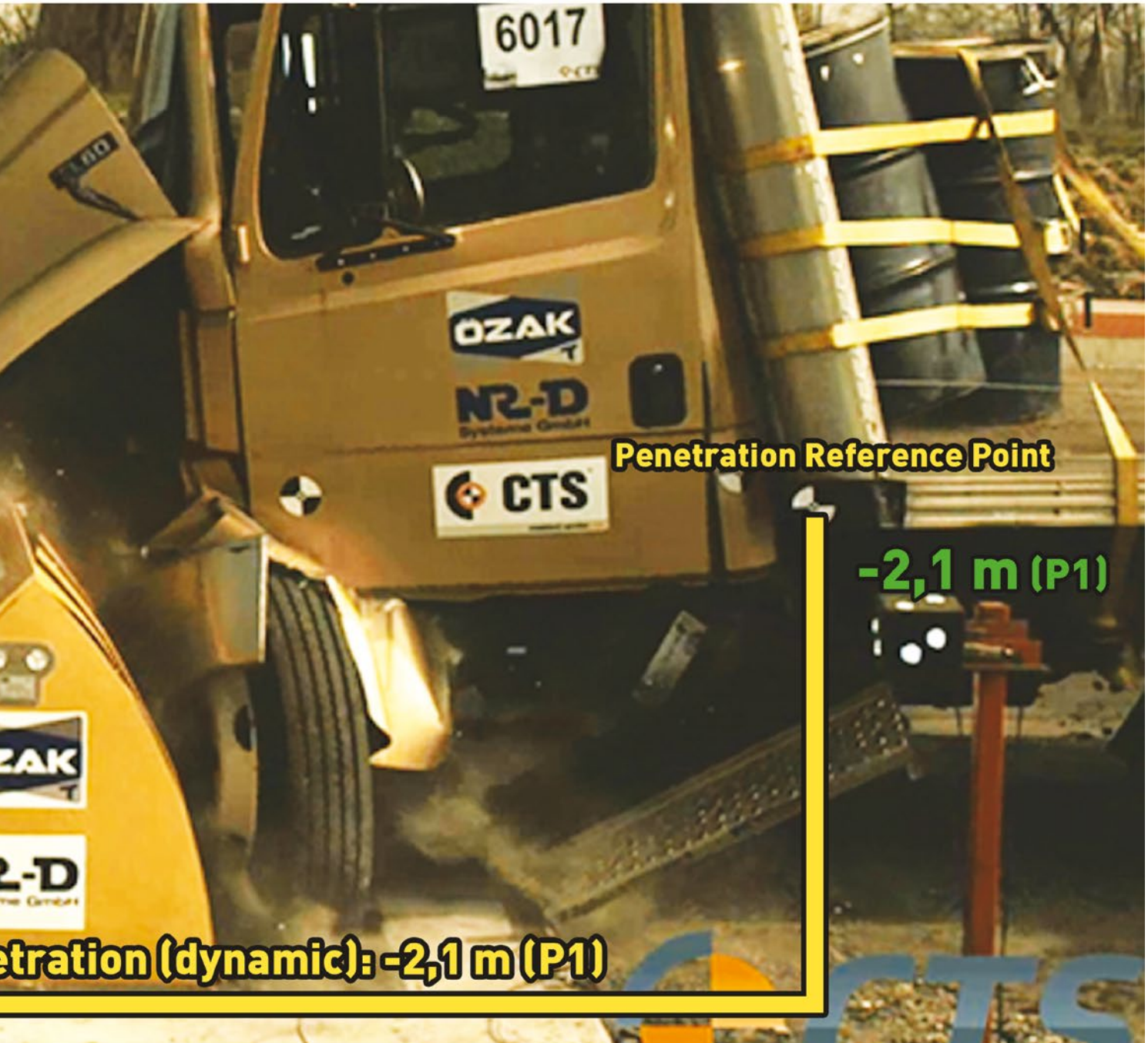





قف



STOP

20

VILLA  
003-70  
001-888  
REGISTRATION





STOP

قف

# RRB ROAD BLOCKER

## (Reinforced Model)



<b>Power</b>	Standard 380V AC 3-Phase 50/60 Hz, 2,2 - 11 kW motor (varies depending on blocker size). Operating with 24V DC in case of power failure is optionally available.																
<b>Control Pack</b>	24V DC powered PLC control unit is placed in power unit cabinet. 24V DC (opt.12V DC / 220V AC) solenoids.																
<b>Speed</b>	Standard operation ~3 - 5 sec. (ascend/descend) depending on road blocker dimensions. Fast raise up (EFO, by optional hydraulic accumulator) ~1 - 1,5 sec. and may differ depending on road blocker dimensions for road blockers wider than 4,0 m.																
<b>IP Rating</b>	IP55 - Hydraulic Power Unit (optionally electronics control unit with IP67 protection box) IP68 - Hydraulic Piston																
<b>Operating Temperature</b>	-5°C / +55°C (opt. -30°C / +70°C)																
<b>Crash / Impact Rating</b>	Designed and produced to withstand impacts mentioned below:																
	<table border="1"> <thead> <tr> <th>Standard</th> <th>Vehicle Type</th> <th>Weight</th> <th>Speed</th> </tr> </thead> <tbody> <tr> <td>ASTM F2656</td> <td>M, C7 (K-8)</td> <td>6800, 7200 kg</td> <td>64 km/h (40 mph)</td> </tr> <tr> <td>PAS 68</td> <td>N2, N3</td> <td>7500 kg</td> <td>64 km/h (40 mph)</td> </tr> <tr> <td>IWA 14-1</td> <td>N2A, N2B, N3C</td> <td>7200 kg</td> <td>64 km/h (40 mph)</td> </tr> </tbody> </table>	Standard	Vehicle Type	Weight	Speed	ASTM F2656	M, C7 (K-8)	6800, 7200 kg	64 km/h (40 mph)	PAS 68	N2, N3	7500 kg	64 km/h (40 mph)	IWA 14-1	N2A, N2B, N3C	7200 kg	64 km/h (40 mph)
Standard	Vehicle Type	Weight	Speed														
ASTM F2656	M, C7 (K-8)	6800, 7200 kg	64 km/h (40 mph)														
PAS 68	N2, N3	7500 kg	64 km/h (40 mph)														
IWA 14-1	N2A, N2B, N3C	7200 kg	64 km/h (40 mph)														
	(Please contact for applicable product dimensions.)																

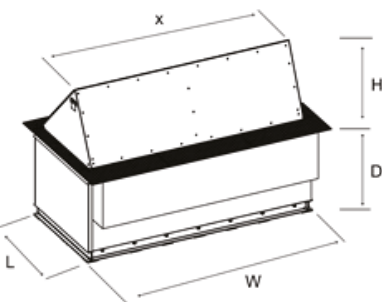

Product Code	Blocker Unit Width (X)	Nr. of Pistons	Raising Height 600 mm	Raising Height 900 mm
			Dimensions (LxWxD)	Dimensions (LxWxD)
RRB 10F_	1000	1	1255 x 1170 x 975	1665 x 1170 x 1270
RRB 15F_	1500	1	1255 x 1670 x 975	1665 x 1670 x 1270
RRB 20F_	2000	1	1255 x 2170 x 975	1665 x 2170 x 1270
RRB 25F_	2500	1	1255 x 2670 x 975	1665 x 2670 x 1270
RRB 30F_	3000	1	1255 x 3170 x 975	1665 x 3170 x 1270
RRB 35F_	3500	1	1255 x 3670 x 975	1665 x 3670 x 1270
RRB 35F_	3500	2	1255 x 3670 x 975	1665 x 3670 x 1270
RRB 40F_	4000	1	1255 x 4170 x 975	1665 x 4170 x 1270
RRB 40F_	4000	2	1255 x 4170 x 975	1665 x 4170 x 1270
RRB 45F_	4500	2	1255 x 4670 x 975	1665 x 4670 x 1270
RRB 50F_	5000	2	1255 x 5170 x 975	1665 x 5170 x 1270
RRB 55F_	5500	2	1255 x 5670 x 975	1665 x 5670 x 1270
RRB 60F_	6000	2	1255 x 6170 x 975	1665 x 6170 x 1270

\* Different raising heights are optionally available.

<b>Axle Load Resistance</b>	50 t
<b>Hydraulic Cylinder Unit</b>	Dust sealed hydraulic cylinder, developed for heavy duty use. 1 - 4 m wide models contain single piston (opt. 3,5 and 4 m wide models contain double pistons). 4,5 - 6,0 m wide models contain double pistons. Contains safety valve for hose bursts.



**Hydraulic Power Unit and Cabinet**

Strengthened industrial hydraulic pump.  
 40 - 120 lt capacity oil tank with magnetic metal collector and suction filter.  
 Built-in oil level and oil temperature indicator.  
 Standard 70 - 150 bar pressure (max. 180 bar).  
 10 m R2 type (double wire braided mesh) reinforced hydraulic hose.



Motor, hydraulic pump and solenoid valves are placed in an easily accessible galvanized and electrostatic powder coated steel cabinet with 2 built-in lock lids (opt. stainless steel cabinet).

Cabinet Type	Width (mm)	Length (mm)	Height (mm)
Cabinet 1	940	570	970
Cabinet 2	1040	590	1285
Cabinet 3	1243	840	1285

\*Suitable cabinet type is selected according to the preferred product configuration.

**System**

Down, up, stop, emergency inputs and external sensor inputs/outputs (e.g. loop detector, safety sensor, traffic light, remote control, etc.).  
 System alerts with an audio signal during lowering and raising operation. A loud siren alert in case of alarm or emergency.  
 System stops in case of emergency as per default set-up and possible to be lowered or raised automatically (user's preference).  
 Can be lowered and raised manually in case of power failure or during maintenance with manual pump and manual valve feature.  
 Automatic raise up mode deploys (available with optional loop detector) the road blocker after the vehicle has passed over.  
 Sensor controlled stopping both at the top and bottom positions of the blocker unit.  
 Free standing piston connection structure that does not put any load on the piston during vehicle passage and in case of an impact.  
 Safety devices (if any, such as; safety sensor, loop detector, etc) are enabled in case fast raise up (EFO, optional) feature is activated and they can be optionally disabled.

**Blocker Unit (Underground Unit)**

All parts are coloured with industrial paint with two components over anticorrosive primer application.  
 Body is structured and strengthened with U-shaped beams. Contains galvanised steel sleeve around main chassis.  
 Product is designed that no vehicle crashing effect can displace it after embedded or installed in to the ground.

**Blocker Unit (Impact Blocking Unit)**

Top plates (vehicle pass through surface) are hot dip galvanised and electrostatic powder coated.  
 All other parts are coloured with industrial paint with two components over anticorrosive primer application.  
 Moving parts are colored with RAL 1003 yellow (impact surface yellow-black) and fixed road surface plates in RAL 9005 black. In addition, the impact surface is finished with reflective signs and warnings.  
 Bulge free hidden hinge structure below the ground level allows vehicles to pass over smoothly and quietly.  
 Impact blocking unit is made of special, reinforced, 6 mm thick vertical impact load distributing panel construction assembled to the main chassis with 350 - 550 mm distance from each other. Each impact load distributing panel is supported with 4 pieces of 30 x 10 mm solid steel bars placed with equal distance from each other so that a strong steel construction has been designed.  
 Impacts are absorbed and blocked by impact load distributing panels together with 6 mm thick steel sheet attached to their front sides and specially formed hook type holders.  
 Top panels where the vehicles pass over are made of 8 / 9 mm thick hot-dip galvanized steel with non-skid surface.  
 The road blocker moves up and down as a block supported by Ø50 mm steel hinges at pivot points, which are welded on the main frame with wedges for extra strength. Number of hinges varies according to blocker width (3 m wide blocker contains 7 pieces of hinges).  
 Impact blocker unit raises with 45° angle from the ground level and equipped with optional flashing indicators on the front panel.  
 A top lid integration is available for easy access to interior units for service and maintenance purposes.

**Control System**

3 buttons for up, down and stop operations and 1 button for emergency stop are contained in a box that is suitable for outdoor use (optionally, 1 button for EFO-fast raise up).  
 System stops its movement with the command from safety sensor (opt.) and loop detectors (opt.).  
 Contains built-in LED indicators and 10 m cable.  
 The system works with PLC as standard.  
 Status of safety sensors (if any) and loop detectors (if any), position and movement of the blocker and low oil level situation of the system can be monitored with optional PLC with diagnostic display.  
 Compatible with any access control system (by third parties).



**Power-off Situation**

Road Blocker remains in its position in case of power-off. Optionally; can be lowered or raised and lowered by battery pack with 24V DC motor. Battery pack provides min.100 movements (50 deploy + 50 retract) when fully charged.

**Optional Features and Accessories**

Hydraulic accumulator for EFO-fast raise up (1 piston or 2 pistons systems), 24V DC motor in case of power failure (50 deploy + 50 retract), oil heater (for oil tank), oil cooler, heater for electronic components, submersible pump, traffic light (Ø200/300 mm, red-green LED, electrostatic powder coated over 304 grade stainless steel body), traffic light pole (electrostatic powder coated over hot dip galvanised steel), loop detector (double contact), safety sensors (with 50 cm height poles), IP67 box (for PLC, SMPS, connectors etc inside power unit), wireless remote control (receiver and transmitter), external buttons, hot dip galvanization, double effect hydraulic unit, double speed hydraulic unit, PLC with diagnostic display, front flashing indicators, oil level sensor, different product dimensions.

**Installation**

Installation with C30 grade concrete and steel rebar reinforcement. Ground levelling and preparation works shall be carried on before pouring the concrete. Allowable bearing value of the ground shall be minimum 1/2 kg/cm<sup>2</sup>, if not, works shall be carried on to fulfil. Installation shall be done according to the manufacturer's instructions.



**UDH**

**T.C.**

**Ulaştırma Denizcilik ve  
Haberleşme Bakanlığı**

**DUR**



**DUR**







# RB ROAD BLOCKER

## (Access Control Model)



<b>Power</b>	Standard 380V AC 3-Phase 50/60 Hz, 2,2 - 11 kW motor (varies depending on blocker size). Operating with 24V DC in case of power failure is optionally available.																
<b>Control Pack</b>	24V DC powered PLC control unit is placed in power unit cabinet. 24V DC (opt.12V DC / 220V AC) solenoids.																
<b>Speed</b>	Standard operation ~3 - 5 sec. (ascend/descend) depending on road blocker dimensions. Fast raise up (EFO, by optional hydraulic accumulator) ~1 - 1,5 sec. and may differ depending on road blocker dimensions for road blockers wider than 4,0 m.																
<b>IP Rating</b>	IP55 - Hydraulic Power Unit (optionally electronics control unit with IP67 protection box) IP68 - Hydraulic Piston																
<b>Operating Temperature</b>	-5°C / +55°C (opt. -30°C / +70°C)																
<b>Crash / Impact Rating</b>	Designed and produced to withstand impacts mentioned below:																
	<table border="1"> <thead> <tr> <th>Standard</th> <th>Vehicle Type</th> <th>Weight</th> <th>Speed</th> </tr> </thead> <tbody> <tr> <td>ASTM F2656</td> <td>M, C7 (K-4)</td> <td>6800, 7200 kg</td> <td>48 km/h (30 mph)</td> </tr> <tr> <td>PAS 68</td> <td>N2, N3</td> <td>7500 kg</td> <td>48 km/h (30 mph)</td> </tr> <tr> <td>IWA 14-1</td> <td>N2A, N2B, N3C</td> <td>7200 kg</td> <td>48 km/h (30 mph)</td> </tr> </tbody> </table>	Standard	Vehicle Type	Weight	Speed	ASTM F2656	M, C7 (K-4)	6800, 7200 kg	48 km/h (30 mph)	PAS 68	N2, N3	7500 kg	48 km/h (30 mph)	IWA 14-1	N2A, N2B, N3C	7200 kg	48 km/h (30 mph)
Standard	Vehicle Type	Weight	Speed														
ASTM F2656	M, C7 (K-4)	6800, 7200 kg	48 km/h (30 mph)														
PAS 68	N2, N3	7500 kg	48 km/h (30 mph)														
IWA 14-1	N2A, N2B, N3C	7200 kg	48 km/h (30 mph)														
	(Please contact for applicable product dimensions.)																

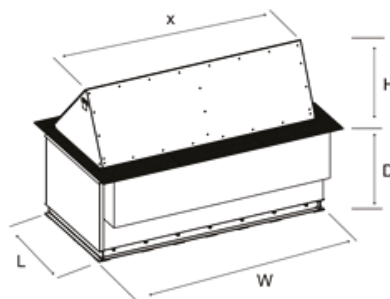

Product Code	Blocker Unit Width (X)	Nr. of Pistons	Raising Height 600 mm	Raising Height 900 mm
			Dimensions (LxWxD)	Dimensions (LxWxD)
RB 10F__	1000	1	1250 x 1160 x 975	1660 x 1160 x 1270
RB 15F__	1500	1	1250 x 1660 x 975	1660 x 1660 x 1270
RB 20F__	2000	1	1250 x 2160 x 975	1660 x 2160 x 1270
RB 25F__	2500	1	1250 x 2660 x 975	1660 x 2660 x 1270
RB 30F__	3000	1	1250 x 3160 x 975	1660 x 3160 x 1270
RB 35F__	3500	1	1250 x 3660 x 975	1660 x 3660 x 1270
RB 35F__	3500	2	1250 x 3660 x 975	1660 x 3660 x 1270
RB 40F__	4000	1	1250 x 4160 x 975	1660 x 4160 x 1270
RB 40F__	4000	2	1250 x 4160 x 975	1660 x 4160 x 1270
RB 45F__	4500	2	1250 x 4660 x 975	1660 x 4660 x 1270
RB 50F__	5000	2	1250 x 5160 x 975	1660 x 5160 x 1270
RB 55F__	5500	2	1250 x 5660 x 975	1660 x 5660 x 1270
RB 60F__	6000	2	1250 x 6160 x 975	1660 x 6160 x 1270

\* Different raising heights are optionally available.

<b>Axle Load Resistance</b>	40 t
<b>Hydraulic Cylinder Unit</b>	Dust sealed hydraulic cylinder, developed for heavy duty use. 1 - 4 m wide models contain single piston (opt. 3,5 and 4 m wide models contain double pistons). 4,5 - 6,0 m wide models contain double pistons. Contains safety valve for hose bursts.





**Hydraulic Power Unit and Cabinet**

Strengthened industrial hydraulic pump.  
 40 - 120 lt capacity oil tank with magnetic metal collector and suction filter.  
 Built-in oil level and oil temperature indicator.  
 Standard 70 - 150 bar pressure (max. 180 bar).  
 10 m R2 type (double wire braided mesh) reinforced hydraulic hose.

Motor, hydraulic pump and solenoid valves are placed in an easily accessible galvanized and electrostatic powder coated steel cabinet with 2 built-in lock lids (opt. stainless steel cabinet).

Cabinet Type	Width (mm)	Length (mm)	Height (mm)
Cabinet 1	940	570	970
Cabinet 2	1040	590	1285
Cabinet 3	1243	840	1285

\* Suitable cabinet type is selected according to the preferred product configuration.

**System**

Down, up, stop, emergency inputs and external sensor inputs/outputs (e.g. loop detector, safety sensor, traffic light, remote control, etc.).  
 System alerts with an audio signal during lowering and raising operation. A loud siren alert in case of alarm or emergency.  
 System stops in case of emergency as per default set-up and possible to be lowered or raised automatically (user's preference).  
 Can be lowered and raised manually in case of power failure or during maintenance with manual pump and manual valve feature.  
 Automatic raise up mode deploys (available with optional loop detector) the road blocker after the vehicle has passed over.  
 Sensor controlled stopping both at the top and bottom positions of the blocker unit.  
 Free standing piston connection structure that does not put any load on the piston during vehicle passage and in case of an impact.  
 Safety devices (if any, such as; safety sensor, loop detector, etc) are enabled in case fast raise up (EFO, optional) feature is activated and they can be optionally disabled.

**Blocker Unit (Underground Unit)**

All parts are coloured with industrial paint with two components over anticorrosive primer application.  
 Body is structured and strengthened with U-shaped beams. Contains galvanised steel sleeve around main chassis.  
 Product is designed that no vehicle crashing effect can displace it after embedded or installed in to the ground.

**Blocker Unit (Impact Blocking Unit)**

Top plates (vehicle pass through surface) are hot dip galvanised and electrostatic powder coated.  
 All other parts are coloured with industrial paint with two components over anticorrosive primer application.  
 Moving parts are colored with RAL 1003 yellow (impact surface yellow-black) and fixed road surface plates in RAL 9005 black. In addition, the impact surface is finished with reflective signs and warnings.  
 Bulge free hidden hinge structure below the ground level allows vehicles to pass over smoothly and quietly.  
 Impact blocking unit is made of special, reinforced, 4 mm thick vertical impact load distributing panel construction assembled to the main chassis with 350 - 550 mm distance from each other. Impacts are absorbed and blocked by impact load distributing panels together with 4 mm thick steel sheet attached to their front sides and specially formed hook type holders.  
 Top panels where the vehicles pass over are made of 8 / 9 mm thick hot-dip galvanized steel with non-skid surface.  
 The road blocker moves up and down as a block supported by Ø50 mm steel hinges at pivot points, which are welded on the main frame with wedges for extra strength. Number of hinges varies according to blocker width (3 m wide blocker contains 7 pieces of hinges).  
 Impact blocker unit raises with 45° angle from the ground level and equipped with optional flashing indicators on the front panel.  
 A top lid integration is available for easy access to interior units for service and maintenance purposes.

**Control System**

3 buttons for up, down and stop operations and 1 button for emergency stop are contained in a box that is suitable for outdoor use (optionally, 1 button for EFO-fast raise up).  
 System stops its movement with the command from safety sensor (opt.) and loop detectors (opt.).  
 Contains built-in LED indicators and 10 m cable.  
 The system works with PLC as standard.  
 Status of safety sensors (if any) and loop detectors (if any), position and movement of the blocker and low oil level situation of the system can be monitored with optional PLC with diagnostic display.  
 Compatible with any access control system (by third parties).



**Power-off Situation**

Road Blocker remains in its position in case of power-off. Optionally; can be lowered or raised and lowered by battery pack with 24V DC motor. Battery pack provides min.100 movements (50 deploy + 50 retract) when fully charged.

**Optional Features and Accessories**

Hydraulic accumulator for EFO-fast raise up (1 piston or 2 pistons systems), 24V DC motor in case of power failure (50 deploy + 50 retract), oil heater (for oil tank), oil cooler, heater for electronic components, submersible pump, traffic light (Ø200/300 mm, red-green LED, electrostatic powder coated over 304 grade stainless steel body), traffic light pole (electrostatic powder coated over hot dip galvanised steel), loop detector (double contact), safety sensors (with 50 cm height poles), IP67 box (for PLC, SMPS, connectors etc inside power unit), wireless remote control (receiver and transmitter), external buttons, hot dip galvanization, double effect hydraulic unit, double speed hydraulic unit, PLC with diagnostic display, front flashing indicators, oil level sensor, different product dimensions.

**Installation**

Installation with C30 grade concrete and steel rebar reinforcement. Ground levelling and preparation works shall be carried on before pouring the concrete. Allowable bearing value of the ground shall be minimum 1/2 kg/cm<sup>2</sup>, if not, works shall be carried on to fulfil. Installation shall be done according to the manufacturer's instructions.



STOP







STOP



# General Technical Specifications

## (Deep Mounted Series)

**HRB**  
(Anti-Terror / Heavy Duty Model)



**RRB**  
(Reinforced Model)

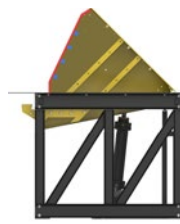

**RB**  
(Access Control Model)



### General Specifications

<b>Crash/Impact Rating</b>	Crash tested and certified according to IWA 14-1:2013 Road Blocker V/7200[N3C]/80, PAS68:2013 Road Blocker V/7500[N3]/80, and ASTM F2656-20 C750/7200 P1 standards <b>(HRB 30 R 110).</b> Crash tested and certified according to ASTM F2656-07 at M50 (K-12) level also designed and produced to withstand impacts according to PAS68[N3]/80 and IWA 14-1[N3C]/80 levels <b>(HRB 30 R 90).</b>	Designed and produced to withstand impacts according to ASTM F2656 M, C7 (K-8), PAS68[N2 N3]/64 and IWA 14-1[N2A/N2B/N3C]/64 levels.	Designed and produced to withstand impacts according to ASTM F2656 M, C7 (K-4), PAS68[N2 N3]/48 and IWA 14-1[N2A/N2B/N3C]/48 levels.
<b>Axle Load Resistance</b>	50 t	50 t	40 t
<b>Impact Surface Thickness</b>	10 mm (+3 mm front Panel)	6 mm	4 mm
<b>Front Panel</b>	Round (replaceable, 3 mm)	-	-
<b>Top Plate Thickness</b>	10/11 mm	8 / 9 mm	8 / 9 mm
<b>Vertical Impact Absorbing Panel Thickness</b>	Solid 6 mm	Solid 6 mm	Solid 4 mm
<b>Flashing Indicator (Front)</b>	Standard	Optional	Optional
<b>Flashing Indicator (Side)</b>	Standard	-	-
<b>Oil Level Sensor</b>	Standard	Optional	Optional

380V AC 3-phase, 50/60 Hz, 2,2 - 11 kW

PLC control unit.

24V DC control system.

24V DC solenoids.

~3 - 5 sec. raising speed (~1 - 1,5 sec. EFO with optional hydraulic accumulator, and may differ depending on road blocker dimensions for road blockers wider than 4,0 m).

IP55 - Hydraulic Power Unit (optionally electronics control unit with IP67 protection box), IP68 - Hydraulic Piston

-5°C / +55°C (opt. -30°C / +70°C) operating temperature.

Safety valve for hose bursts.

10 m R2 type (double wire braided mesh) hydraulic hose.

40 - 120 lt capacity oil tank with magnetic metal collector and suction filter.

Oil level and temperature indicator.

Electrostatic powder coated over galvanised steel (opt. stainless steel) hydraulic power unit (HPU) cabinet.

External inputs/outputs (e.g. loop detector, safety sensor, traffic light, remote control, etc.).

Audio signal during lowering and raising operation.

Automatic / manual programmable passage authorisation (with optional loop detector).

Manual raising hand pump / Manual lowering valve.

Galvanized steel sleeve around main chassis (underground unit).

Special design hinge system spread on overall width.

Top plates (vehicle pass through surface) are hot dip galvanised and electrostatic powder coated anti skid steel. All other parts are coloured with industrial paint with two components over anticorrosive primer application.

High resistant construction by welded, bolted and wedge type connection structure.

Free standing piston connection structure avoiding load on the piston during vehicle passage and in case of an impact.

Manual control button unit, that is suitable for outdoor use, with 3 functions.

Emergency stop button.

High visibility with yellow and black diagonal stripes on impact surface.

Reflective marking.

Easy installation with installation apparatus.

### Optional Features and Accessories

Hydraulic accumulator for EFO-fast raise up (1 piston or 2 pistons systems), 24V DC motor in case of power failure (50 deploy + 50 retract), oil heater (for oil tank), oil cooler, heater for electronic components, submersible pump, traffic light (Ø200/300 mm, red-green LED, electrostatic powder coated over 304 grade stainless steel body), traffic light pole (electrostatic powder coated over hot dip galvanised steel), loop detector (double contact), safety sensors (with 50 cm height poles), IP67 box (for PLC, SMPS, connectors etc. inside power unit), wireless remote control (receiver and transmitter), external buttons, hot dip galvanization, double effect hydraulic unit, double speed hydraulic unit, PLC with diagnostic display, front flashing indicators, oil level sensor, different product dimensions, stainless steel HPU cabinet.













STOP







**DUR**



**STOP**



## ROAD BLOCKERS

### SHALLOW MOUNT SERIES

40	HRB SHLW (ANTI-TERROR / HEAVY DUTY - SHALLOW MOUNT MODEL)
44	RRB SHLW (REINFORCED - SHALLOW MOUNT MODEL)
48	RB SHLW (ACCESS CONTROL - SHALLOW MOUNT MODEL)
50	TRB (TRAFFIC REGULATION - SHALLOW MOUNT MODEL)
52	GENERAL TECHNICAL SPECIFICATIONS (SHALLOW MOUNT)

# HRB SHLW ROAD BLOCKER

## (Anti-terror / Heavy Duty - Shallow Mount Model)



**PAS 68 (N3)**  
**IWA 14 (N3C)**  
**ASTM F2656 (C750)**

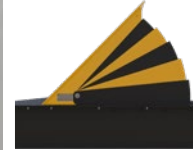

<b>Power</b>	Standard 380V AC 3-Phase 50/60 Hz, 2,2 - 11 kW motor (varies depending on blocker size). Operating with 24V DC in case of power failure is optionally available.
<b>Control Pack</b>	24V DC powered PLC control unit is placed in power unit cabinet. 24V DC (opt. 12V DC / 220V AC) solenoids.
<b>Speed</b>	Standard operation ~3 - 5 sec. (ascend/descend) depending on road blocker dimensions. Fast raise up (EFO, by optional hydraulic accumulator) ~1 - 1,5 sec. and may differ depending on road blocker dimensions for road blockers wider than 4,0 m.
<b>IP Rating</b>	IP55 - Hydraulic Power Unit (optionally electronics control unit with IP67 protection box) IP68 - Hydraulic Piston
<b>Operating Temperature</b>	-5°C / +55°C (opt. -30°C / +70°C)
<b>Crash / Impact Rating</b>	Crash tested and certified according to: IWA 14-1:2013 Road Blocker V/7200[N3C]/80, PAS68:2013 Road Blocker V/7500[N3]/80, and ASTM F2656-18 C750/7200 standards (HRB 30 P 90 SHLW model).

Product Code	Mounting Depth 400 mm	Nr. of Pistons	Raising Height (H) 900 mm
	Blocker Unit Width - mm (X)		Dimensions - mm (LxWxD)
HRB 20P 90 SHLW	2000	1	2200 x 2450 x 400
HRB 25P 90 SHLW	2500	1	2200 x 2950 x 400
HRB 30P 90 SHLW	3000	1	2200 x 3450 x 400
HRB 35P 90 SHLW	3500	2	2200 x 3950 x 400
HRB 40P 90 SHLW	4000	2	2200 x 4450 x 400
HRB 45P 90 SHLW	4500	2	2200 x 4950 x 400
HRB 50P 90 SHLW	5000	2	2200 x 5450 x 400
HRB 55P 90 SHLW	5500	2	2200 x 5950 x 400
HRB 60P 90 SHLW	6000	2	2200 x 6450 x 400

\* Different raising heights are optionally available.

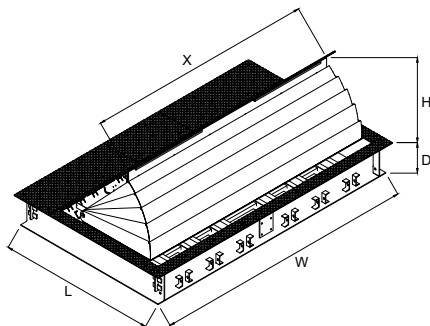

<b>Axle Load Resistance</b>	50 t
<b>Hydraulic Cylinder Unit</b>	Dust sealed hydraulic cylinder, developed for heavy duty use. 1 - 3 m wide models contain single piston. 3,5 - 6,0 m wide models contain double pistons. Contains safety valve for hose bursts.
<b>Hydraulic Power Unit and Cabinet</b>	Strengthened industrial hydraulic pump. 40 - 120 lt capacity oil tank with magnetic metal collector and suction filter. Built-in oil level indicator and sensor, oil temperature indicator and audio alarm feature for low oil level. Standard 70 - 150 bar pressure (max. 180 bar). 10 m R2 type (double wire braided mesh) reinforced hydraulic hose.





Motor, hydraulic pump and solenoid valves are placed in an easily accessible galvanized and electrostatic powder coated steel cabinet with 2 built-in lock lids (opt. stainless steel cabinet).

Cabinet Type	Width (mm)	Length (mm)	Height (mm)
Cabinet 1	940	570	970
Cabinet 2	1040	590	1285
Cabinet 3	1243	840	1285

\*Suitable cabinet type is selected according to the preferred product configuration.

**System**  
 Down, up, stop, emergency inputs and external sensor inputs/outputs (e.g. loop detector, safety sensor, traffic light, remote control, etc.). System alerts with an audio signal during lowering and raising operation. A loud siren alert in case of alarm or emergency. System stops in case of emergency as per default set-up and possible to be lowered or raised automatically (user's preference). Can be lowered and raised manually in case of power failure or during maintenance with manual pump and manual valve feature. Automatic raise up mode deploys (available with optional loop detector) the road blocker after the vehicle has passed over. Sensor controlled stopping both at the top and bottom positions of the blocker unit. Free standing piston connection structure that does not put any load on the piston during vehicle passage and in case of an impact. Safety devices (if any, such as; safety sensor, loop detector, etc) are enabled in case fast raise up (EFO, optional) feature is activated and they can be optionally disabled.

**Blocker Unit (Underground Unit)**  
 All parts are coloured with industrial paint with two components over anticorrosive primer application. Body is structured and strengthened with U-shaped beams. Product is designed that no vehicle crashing effect can displace it after embedded or installed in to the ground.

**Blocker Unit (Impact Blocking Unit)**  
 Top plates (vehicle pass through surface) are hot dip galvanised and electrostatic powder coated. All other parts are coloured with industrial paint with two components over anticorrosive primer application. Moving parts are colored with RAL 1003 yellow (impact surface yellow-black) and fixed road surface plates in RAL 9005 black. In addition, the impact surface is finished with reflective signs and warnings. Bulge free hidden hinge structure below the ground level allows vehicles to pass over smoothly and quietly. Top panels where the vehicles pass over are made of 10/11 mm thick hot-dip galvanized steel with non-skid surface. The road blocker moves up and down as a block supported by Ø60 mm steel hinges at pivot points, which are welded on the main frame with wedges for extra strength. Number of hinges varies according to blocker width (3 m wide blocker contains 8 pieces of hinges). Impact blocker unit raises with 45° angle from the ground level. Impact blocking unit and the underground unit are connected with 6 sets (in 3 m long road blocker, varies according to road blocker width) of linkages in 2 pairs of 15 mm each fastened together by stainless steel shafts of 40 mm diameter. When the blocker is in the raised position, impacts are distributed to the linkages and also it is designed so that the vertical impact power distribution panels are designed to absorb the impact by transmitting the impact energy to the ground. The 10 mm thick impact surface strength is increased by the impact power distribution panels and the U-shaped beams connecting these panels together behind it. Front and side faces of the blocker unit are covered with decorative telescopic panels (opt.). A top lid integration is available for easy access to interior units for service and maintenance purposes.

**Control System**  
 3 buttons for up, down and stop operations and 1 button for emergency stop are contained in a box that is suitable for outdoor use (optionally, 1 button for EFO-fast raise up). System stops its movement with the command from safety sensor (opt.) and loop detectors (opt.). Contains built-in LED indicators and 10 m cable. The system works with PLC as standard. Status of safety sensors (if any) and loop detectors (if any), position and movement of the blocker and low oil level situation of the system can be monitored with optional PLC with diagnostic display. Compatible with any access control system (by third parties).



**Power-off Situation**  
 Road Blocker remains in its position in case of power-off. Optionally; can be lowered or raised and lowered by battery pack with 24V DC motor. Battery pack provides min.100 movements (50 deploy + 50 retract) when fully charged.

**Optional Features and Accessories**  
 Telescopic front panels, hydraulic accumulator for EFO-fast raise up (1 piston or 2 pistons systems), 24V DC motor in case of power failure (50 deploy + 50 retract), oil heater (for oil tank), oil cooler, heater for electronic components, submersible pump, traffic light (Ø200/300 mm, red-green LED, electrostatic powder coated over 304 grade stainless steel body), traffic light pole (electrostatic powder coated over hot dip galvanised steel), loop detector (double contact), safety sensors (with 50 cm height poles), IP67 box (for PLC, SMPS, connectors etc inside power unit), wireless remote control (receiver and transmitter), external buttons, hot dip galvanization, double effect hydraulic unit, double speed hydraulic unit, PLC with diagnostic display, front flashing indicators, different product dimensions.

**Installation**  
 Installation with C30 grade concrete and steel rebar reinforcement. Ground levelling and preparation works shall be carried on before pouring the concrete. Allowable bearing value of the ground shall be minimum 1/2 kg/cm<sup>2</sup>, if not, works shall be carried on to fulfil. Installation shall be done according to the manufacturer's instructions.

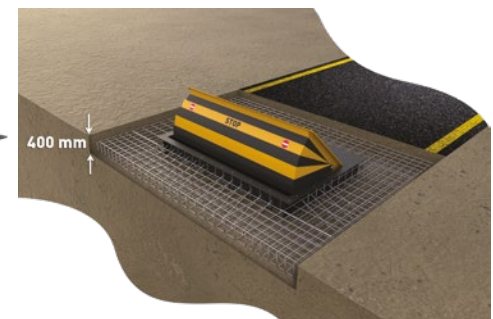
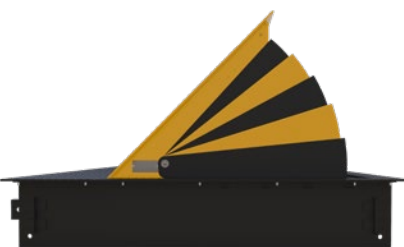

\*Design and specifications are subject to change without notice.





**IWA 14-1:2013 7200[N3C]/80**  
**PAS68:2013 7500[N3]/80**  
**ASTM F2656-18 C750/7200**

**Penetration Reference Point**



for crash  
test video





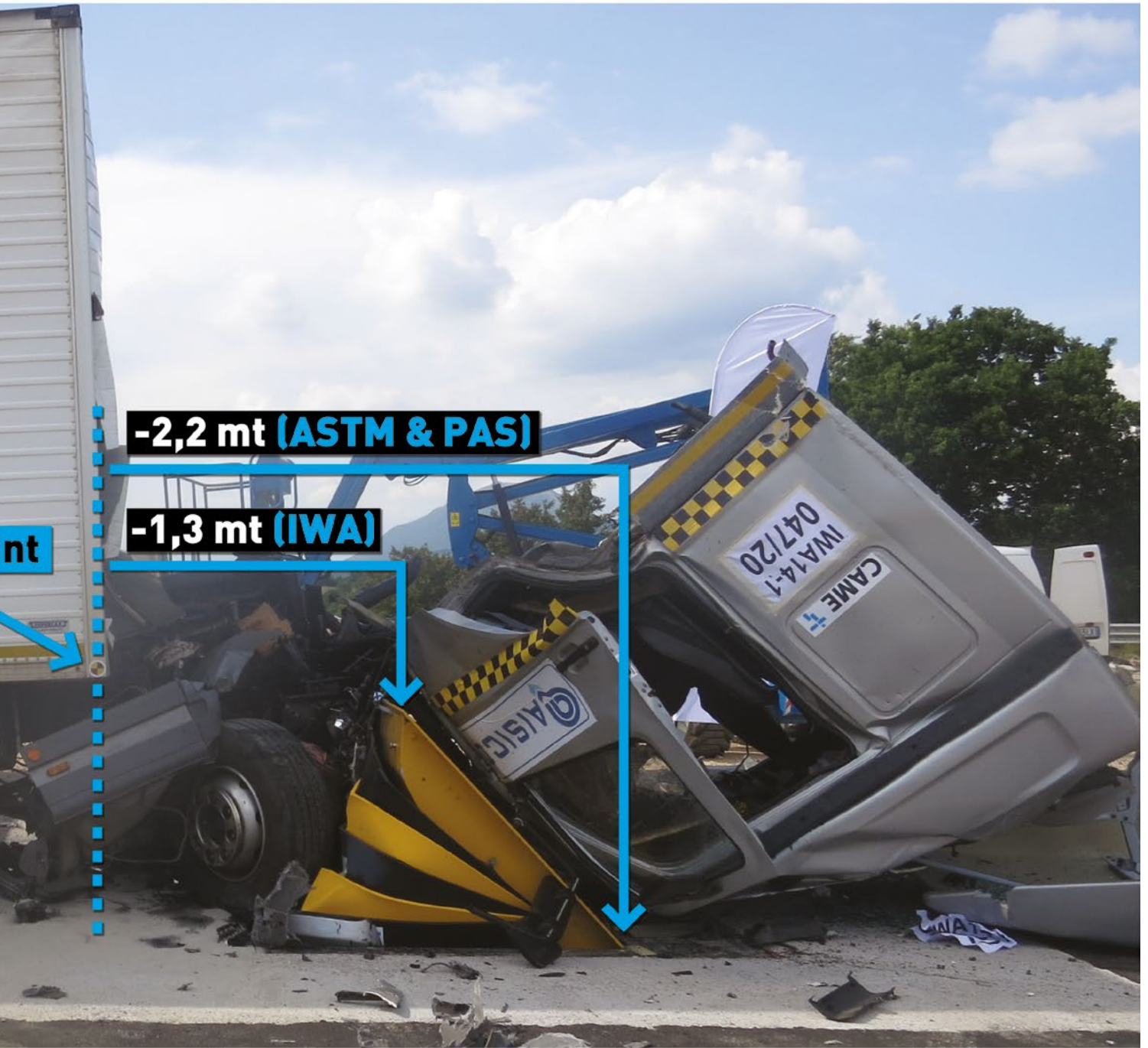

# RRB SHLW ROAD BLOCKER

## (Reinforced - Shallow Mount Model)



<b>Power</b>	Standard 380V AC 3-Phase 50/60 Hz, 2,2 - 11 kW motor (varies depending on blocker size). Operating with 24V DC in case of power failure is optionally available.																
<b>Control Pack</b>	24V DC powered PLC control unit is placed in power unit cabinet. 24V DC (opt.12V DC / 220V AC) solenoids.																
<b>Speed</b>	Standard operation ~3 - 5 sec. (ascend/descend) depending on road blocker dimensions. Fast raise up (EFO, by optional hydraulic accumulator) ~1 - 1,5 sec. and may differ depending on road blocker dimensions for road blockers wider than 4,0 m.																
<b>IP Rating</b>	IP55 - Hydraulic Power Unit (optionally electronics control unit with IP67 protection box) IP68 - Hydraulic Piston																
<b>Operating Temperature</b>	-5°C / +55°C (opt. -30°C / +70°C)																
<b>Crash / Impact Rating</b>	Designed and produced to withstand impacts mentioned below:																
	<table border="1"> <thead> <tr> <th>Standard</th> <th>Vehicle Type</th> <th>Weight</th> <th>Speed</th> </tr> </thead> <tbody> <tr> <td>ASTM F2656</td> <td>M, C7 (K-8)</td> <td>6800, 7200 kg</td> <td>64 km/h (40 mph)</td> </tr> <tr> <td>PAS 68</td> <td>N2, N3</td> <td>7500 kg</td> <td>64 km/h (40 mph)</td> </tr> <tr> <td>IWA 14-1</td> <td>N2A, N2B, N3C</td> <td>7200 kg</td> <td>64 km/h (40 mph)</td> </tr> </tbody> </table>	Standard	Vehicle Type	Weight	Speed	ASTM F2656	M, C7 (K-8)	6800, 7200 kg	64 km/h (40 mph)	PAS 68	N2, N3	7500 kg	64 km/h (40 mph)	IWA 14-1	N2A, N2B, N3C	7200 kg	64 km/h (40 mph)
Standard	Vehicle Type	Weight	Speed														
ASTM F2656	M, C7 (K-8)	6800, 7200 kg	64 km/h (40 mph)														
PAS 68	N2, N3	7500 kg	64 km/h (40 mph)														
IWA 14-1	N2A, N2B, N3C	7200 kg	64 km/h (40 mph)														
	(Please contact for applicable product dimensions)																

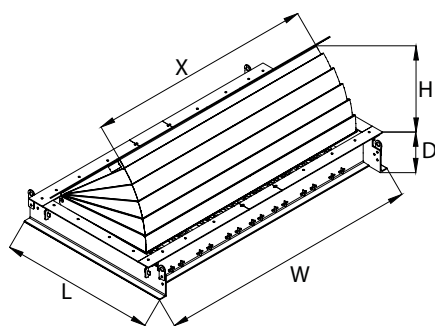

Product Code	Mounting Depth 390 mm	Nr. of Pistons	Raising Height 900 mm
	Blocker Unit Width - mm (X)		Dimensions - mm (LxWxD)
RRB 10P 90 SHLW	1000	1	2000 x 1455 x 390
RRB 15P 90 SHLW	1500	1	2000 x 1955 x 390
RRB 20P 90 SHLW	2000	1	2000 x 2455 x 390
RRB 25P 90 SHLW	2500	1	2000 x 2955 x 390
RRB 30P 90 SHLW	3000	1	2000 x 3455 x 390
RRB 35P 90 SHLW	3500	2	2000 x 3955 x 390
RRB 40P 90 SHLW	4000	2	2000 x 4455 x 390
RRB 45P 90 SHLW	4500	2	2000 x 4955 x 390
RRB 50P 90 SHLW	5000	2	2000 x 5455 x 390
RRB 55P 90 SHLW	5500	2	2000 x 5955 x 390
RRB 60P 90 SHLW	6000	2	2000 x 6455 x 390

\* Different raising heights are optionally available.

<b>Axle Load Resistance</b>	50 t
<b>Hydraulic Cylinder Unit</b>	Dust sealed hydraulic cylinder, developed for heavy duty use. 1 - 3 m wide models contain single piston. 3,5 - 6,0 m wide models contain double pistons. Contains safety valve for hose bursts.
<b>Hydraulic Power Unit and Cabinet</b>	Strengthened industrial hydraulic pump. 40 - 120 lt capacity oil tank with magnetic metal collector and suction filter. Built-in oil level and oil temperature indicator. Standard 70 - 150 bar pressure (max. 180 bar). 10 m R2 type (double wire braided mesh) reinforced hydraulic hose.





Motor, hydraulic pump and solenoid valves are placed in an easily accessible galvanized and electrostatic powder coated steel cabinet with 2 built-in lock lids (opt. stainless steel cabinet).

Cabinet Type	Width (mm)	Length (mm)	Height (mm)
Cabinet 1	940	570	970
Cabinet 2	1040	590	1285
Cabinet 3	1243	840	1285

\*Suitable cabinet type is selected according to the preferred product configuration.

**System**  
 Down, up, stop, emergency inputs and external sensor inputs/outputs (e.g. loop detector, safety sensor, traffic light, remote control, etc.). System alerts with an audio signal during lowering and raising operation. A loud siren alert in case of alarm or emergency. System stops in case of emergency as per default set-up and possible to be lowered or raised automatically (user's preference). Can be lowered and raised manually in case of power failure or during maintenance with manual pump and manual valve feature. Automatic raise up mode deploys (available with optional loop detector) the road blocker after the vehicle has passed over. Sensor controlled stopping both at the top and bottom positions of the blocker unit. Free standing piston connection structure that does not put any load on the piston during vehicle passage and in case of an impact. Safety devices (if any, such as; safety sensor, loop detector, etc) are enabled in case fast raise up (EFO, optional) feature is activated and they can be optionally disabled.

**Blocker Unit (Underground Unit)**  
 All parts are coloured with industrial paint with two components over anticorrosive primer application. Body is structured and strengthened with U-shaped beams. Product is designed that no vehicle crashing effect can displace it after embedded or installed in to the ground.

**Blocker Unit (Impact Blocking Unit)**  
 Top plates (vehicle pass through surface) are hot dip galvanised and electrostatic powder coated. All other parts are coloured with industrial paint with two components over anticorrosive primer application. Moving parts are colored with RAL 1003 yellow (impact surface yellow-black) and fixed road surface plates in RAL 9005 black. In addition, the impact surface is finished with reflective signs and warnings. Bulge free hidden hinge structure below the ground level allows vehicles to pass over smoothly and quietly. Top panels where the vehicles pass over are made of 8 / 9 mm thick hot-dip galvanized steel with non-skid surface. The road blocker moves up and down as a block supported by Ø50 mm steel hinges at pivot points, which are welded on the main frame with wedges for extra strength. Number of hinges varies according to blocker width (3 m wide blocker contains 6 pieces of hinges). Impact blocker unit raises with 45° angle from the ground level. Impact blocking unit and the underground unit are connected with 6 sets (in 3 m long road blocker, varies according to road blocker width) of linkages in 2 pairs of 15 mm each fastened together by stainless steel shafts of 30 mm diameter. When the blocker is in the raised position, impacts are distributed to the linkages and also it is designed so that the vertical impact power distribution panels are designed to absorb the impact by transmitting the impact energy to the ground. 6+5 mm thick impact surface strength is increased by the impact power distribution panels and the U-shaped beams connecting these panels together behind it. Front and side faces of the blocker unit are covered with decorative telescopic panels (opt.). A top lid integration is available for easy access to interior units for service and maintenance purposes.

**Control System**  
 3 buttons for up, down and stop operations and 1 button for emergency stop are contained in a box that is suitable for outdoor use (optionally, 1 button for EFO-fast raise up). System stops its movement with the command from safety sensor (opt.) and loop detectors (opt.). Contains built-in LED indicators and 10 m cable. The system works with PLC as standard. Status of safety sensors (if any) and loop detectors (if any), position and movement of the blocker and low oil level situation of the system can be monitored with optional PLC with diagnostic display. Compatible with any access control system (by third parties).



**Power-off Situation**  
 Road Blocker remains in its position in case of power-off. Optionally; can be lowered or raised and lowered by battery pack with 24V DC motor. Battery pack provides min.100 movements (50 deploy + 50 retract) when fully charged.

**Optional Features and Accessories**  
 Telescopic front panels, hydraulic accumulator for EFO-fast raise up (1 piston or 2 pistons systems), 24V DC motor in case of power failure (50 deploy + 50 retract), oil heater (for oil tank), oil cooler, heater for electronic components, submersible pump, traffic light (Ø200/300 mm, red-green LED, electrostatic powder coated over 304 grade stainless steel body), traffic light pole (electrostatic powder coated over hot dip galvanised steel), loop detector (double contact), safety sensors (with 50 cm height poles), IP67 box (for PLC, SMPS, connectors etc inside power unit), wireless remote control (receiver and transmitter), external buttons, hot dip galvanization, double effect hydraulic unit, double speed hydraulic unit, PLC with diagnostic display, front flashing indicators, oil level sensor, different product dimensions.

**Installation**  
 Installation with C35 grade concrete and steel rebar reinforcement. Ground levelling and preparation works shall be carried on before pouring the concrete. Allowable bearing value of the ground shall be minimum 1/2 kg/cm<sup>2</sup>, if not, works shall be carried on to fulfil. Installation shall be done according to the manufacturer's instructions.

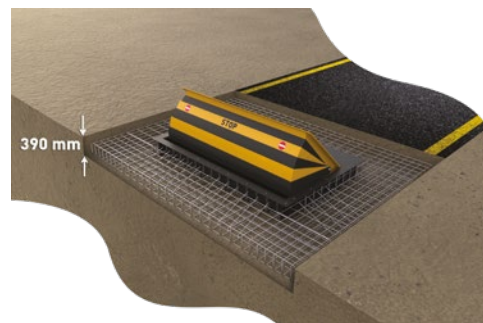

\*Design and specifications are subject to change without notice.









BR/ A  
ni  
N/A  
OR  
OBK  
/ MO  
JANT





# RB SHLW ROAD BLOCKER

## (Access Control - Shallow Mount Model)



<b>Power</b>	Standard 380V AC 3-Phase 50/60 Hz, 2,2 - 11 kW motor (varies depending on blocker size). Operating with 24V DC in case of power failure is optionally available.																
<b>Control Pack</b>	24V DC powered PLC control unit is placed in power unit cabinet. 24V DC (opt.12V DC / 220V AC) solenoids.																
<b>Speed</b>	Standard operation ~3 - 5 sec. (ascend/descend) depending on road blocker dimensions. Fast raise up (EFO, by optional hydraulic accumulator) ~1 - 1,5 sec. and may differ depending on road blocker dimensions for road blockers wider than 4,0 m.																
<b>IP Rating</b>	IP55 - Hydraulic Power Unit (optionally electronics control unit with IP67 protection box) IP68 - Hydraulic Piston																
<b>Operating Temperature</b>	5°C / +55°C (opt. -30°C / +70°C)																
<b>Crash / Impact Rating</b>	Designed and produced to withstand impacts mentioned below:																
	<table border="1"> <thead> <tr> <th>Standard</th> <th>Vehicle Type</th> <th>Weight</th> <th>Speed</th> </tr> </thead> <tbody> <tr> <td>ASTM F2656</td> <td>M, C7 (K-4)</td> <td>6800, 7200 kg</td> <td>48 km/h (30 mph)</td> </tr> <tr> <td>PAS 68</td> <td>N2, N3</td> <td>7500 kg</td> <td>48 km/h (30 mph)</td> </tr> <tr> <td>IWA 14-1</td> <td>N2A, N2B, N3C</td> <td>7200 kg</td> <td>48 km/h (30 mph)</td> </tr> </tbody> </table>	Standard	Vehicle Type	Weight	Speed	ASTM F2656	M, C7 (K-4)	6800, 7200 kg	48 km/h (30 mph)	PAS 68	N2, N3	7500 kg	48 km/h (30 mph)	IWA 14-1	N2A, N2B, N3C	7200 kg	48 km/h (30 mph)
Standard	Vehicle Type	Weight	Speed														
ASTM F2656	M, C7 (K-4)	6800, 7200 kg	48 km/h (30 mph)														
PAS 68	N2, N3	7500 kg	48 km/h (30 mph)														
IWA 14-1	N2A, N2B, N3C	7200 kg	48 km/h (30 mph)														
	(Please contact for applicable product dimensions)																

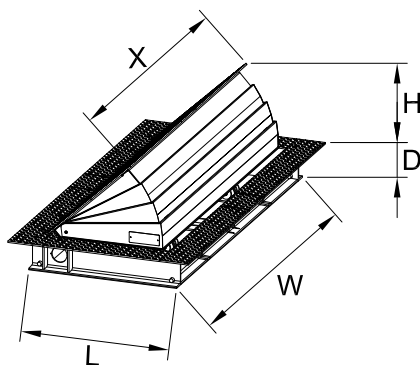

Product Code	Blocker Unit Width (X)	Nr. of Pistons	Mounting Depth 290 mm	Raising Height 900 mm
			Dimensions (LxWxD)	
RB 10P 90 SHLW	1000	1	2000 x 1565 x 290	
RB 15P 90 SHLW	1500	1	2000 x 2065 x 290	
RB 20P 90 SHLW	2000	1	2000 x 2565 x 290	
RB 25P 90 SHLW	2500	1	2000 x 3065 x 290	
RB 30P 90 SHLW	3000	1	2000 x 3565 x 290	
RB 35P 90 SHLW	3500	2	2000 x 4065 x 290	
RB 40P 90 SHLW	4000	2	2000 x 4565 x 290	
RB 45P 90 SHLW	4500	2	2000 x 5065 x 290	
RB 50P 90 SHLW	5000	2	2000 x 5565 x 290	
RB 55P 90 SHLW	5500	2	2000 x 6065 x 290	
RB 60P 90 SHLW	6000	2	2000 x 6565 x 290	

\* Different raising heights are optionally available.

<b>Axle Load Resistance</b>	40 t
<b>Hydraulic Cylinder Unit</b>	Dust sealed hydraulic cylinder, developed for heavy duty use. 1 - 3 m wide models contain single piston. 3,5 - 6,0 m wide models contain double pistons. Contains safety valve for hose bursts.
<b>Hydraulic Power Unit and Cabinet</b>	Strengthened industrial hydraulic pump. 40 - 120 lt capacity oil tank with magnetic metal collector and suction filter. Built-in oil level and oil temperature indicator. Standard 70 - 150 bar pressure (max. 180 bar). 10 m R2 type (double wire braided mesh) reinforced hydraulic hose.





Motor, hydraulic pump and solenoid valves are placed in an easily accessible galvanized and electrostatic powder coated steel cabinet with 2 built-in lock lids (opt. stainless steel cabinet).

Cabinet Type	Width (mm)	Length (mm)	Height (mm)
Cabinet 1	940	570	970
Cabinet 2	1040	590	1285
Cabinet 3	1243	840	1285

\*Suitable cabinet type is selected according to the preferred product configuration.

**System**  
 Down, up, stop, emergency inputs and external sensor inputs/outputs (e.g. loop detector, safety sensor, traffic light, remote control, etc.). System alerts with an audio signal during lowering and raising operation. A loud siren alert in case of alarm or emergency. System stops in case of emergency as per default set-up and possible to be lowered or raised automatically (user's preference). Can be lowered and raised manually in case of power failure or during maintenance with manual pump and manual valve feature. Automatic raise up mode deploys (available with optional loop detector) the road blocker after the vehicle has passed over. Sensor controlled stopping both at the top and bottom positions of the blocker unit. Free standing piston connection structure that does not put any load on the piston during vehicle passage and in case of an impact. Safety devices (if any, such as; safety sensor, loop detector, etc) are enabled in case fast raise up (EFO, optional) feature is activated and they can be optionally disabled.

**Blocker Unit (Underground Unit)**  
 All parts are coloured with industrial paint with two components over anticorrosive primer application. Body is structured and strengthened with U-shaped beams. Product is designed that no vehicle crashing effect can displace it after embedded or installed in to the ground.

**Blocker Unit (Impact Blocking Unit)**  
 Top plates (vehicle pass through surface) are hot dip galvanised and electrostatic powder coated. All other parts are coloured with industrial paint with two components over anticorrosive primer application. Moving parts are colored with RAL 1003 yellow (impact surface yellow-black) and fixed road surface plates in RAL 9005 black. In addition, the impact surface is finished with reflective signs and warnings. Bulge free hidden hinge structure below the ground level allows vehicles to pass over smoothly and quietly. Top panels where the vehicles pass over are made of 8 / 9 mm thick hot-dip galvanized steel with non-skid surface. The road blocker moves up and down as a block supported by Ø50 mm steel hinges at pivot points, which are welded on the main frame with wedges for extra strength. Number of hinges varies according to blocker width (3 m wide blocker contains 6 pieces of hinges). Impact blocker unit raises with 45° angle from the ground level. Impact blocking unit and the underground unit are connected with 6 sets (in 3 m long road blocker, varies according to road blocker width) of linkages in 2 pairs of 15 mm each fastened together by stainless steel shafts of 30 mm diameter. Impact surface is made of 6 mm thick interlocking U-shaped beams structure and vertical impact power distribution U-shaped beams connected to them. Front and side faces of the blocker unit are covered with decorative telescopic panels (opt.). A top lid integration is available for easy access to interior units for service and maintenance purposes.

**Control System**  
 3 buttons for up, down and stop operations and 1 button for emergency stop are contained in a box that is suitable for outdoor use (optionally, 1 button for EFO-fast raise up). System stops its movement with the command from safety sensor (opt.) and loop detectors (opt.). Contains built-in LED indicators and 10 m cable. The system works with PLC as standard. Status of safety sensors (if any) and loop detectors (if any), position and movement of the blocker and low oil level situation of the system can be monitored with optional PLC with diagnostic display. Compatible with any access control system (by third parties).



**Power-off Situation**  
 Road Blocker remains in its position in case of power-off. Optionally; can be lowered or raised and lowered by battery pack with 24V DC motor. Battery pack provides min.100 movements (50 deploy + 50 retract) when fully charged.

**Optional Features and Accessories**  
 Telescopic front panels, hydraulic accumulator for EFO-fast raise up (1 piston or 2 pistons systems), 24V DC motor in case of power failure (50 deploy + 50 retract), oil heater (for oil tank), oil cooler, heater for electronic components, submersible pump, traffic light (Ø200/300 mm, red-green LED, electrostatic powder coated over 304 grade stainless steel body), traffic light pole (electrostatic powder coated over hot dip galvanised steel), loop detector (double contact), safety sensors (with 50 cm height poles), IP67 box (for PLC, SMPS, connectors etc inside power unit), wireless remote control (receiver and transmitter), external buttons, hot dip galvanization, double effect hydraulic unit, double speed hydraulic unit, PLC with diagnostic display, front flashing indicators, oil level sensor, different product dimensions.

**Installation**  
 Installation with C35 grade concrete and steel rebar reinforcement. Ground levelling and preparation works shall be carried on before pouring the concrete. Allowable bearing value of the ground shall be minimum 1/2 kg/cm<sup>2</sup>, if not, works shall be carried on to fulfil. Installation shall be done according to the manufacturer's instructions.

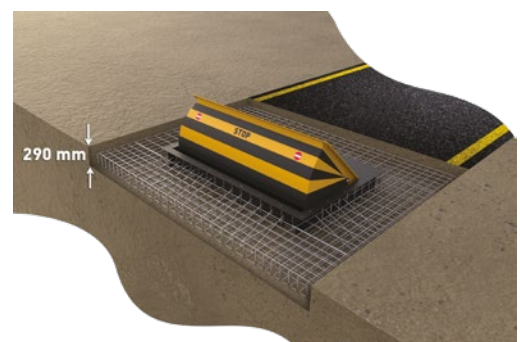

# TRB ROAD BLOCKER

## (Traffic Regulation - Shallow Mount Mode)

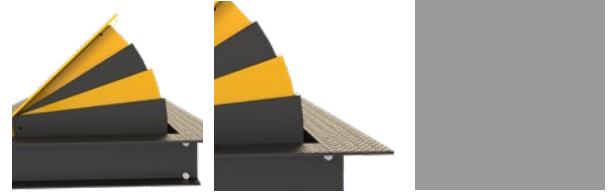

<b>Power</b>	Standard 380V AC 3-Phase 50/60 Hz, 2,2 - 11 kW motor (varies depending on blocker size). Operating with 24V DC in case of power failure is optionally available.
<b>Control Pack</b>	24V DC powered PLC control unit is placed in power unit cabinet. 24V DC (opt. 12V DC / 220V AC) solenoids.
<b>Speed</b>	Standard operation ~3 - 5 sec. (ascend/descend) depending on road blocker dimensions. Fast raise up (EFO, by optional hydraulic accumulator) ~1 - 1,5 sec. and may differ depending on road blocker dimensions for road blockers wider than 4,0 m.
<b>IP Rating</b>	IP55 - Hydraulic Power Unit (optionally electronics control unit with IP67 protection box) IP68 - Hydraulic Piston
<b>Operating Temperature</b>	-5°C / +55°C (opt. -30°C / +70°C)
<b>Crash / Impact Rating</b>	-

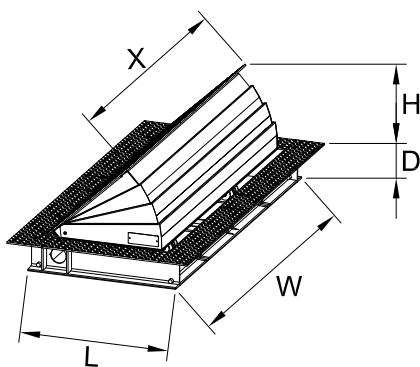

Product Code	Blocker Unit Width (X)	Nr. of Pistons	Mounting Depth 210 mm	Raising Height 500 mm	Raising Height 600 mm
			Dimensions (LxWxD)	Dimensions (LxWxD)	Dimensions (LxWxD)
TRB 10P__SHLW	1000	1	980 x 1210 x 210	1142 x 1240 x 210	
TRB 15P__SHLW	1500	1	980 x 1710 x 210	1142 x 1740 x 210	
TRB 20P__SHLW	2000	1	980 x 2210 x 210	1142 x 2240 x 210	
TRB 25P__SHLW	2500	1	980 x 2710 x 210	1142 x 2740 x 210	
TRB 30P__SHLW	3000	1	980 x 3210 x 210	1142 x 3240 x 210	
TRB 35P__SHLW	3500	2	980 x 3710 x 210	1142 x 3740 x 210	
TRB 40P__SHLW	4000	2	980 x 4210 x 210	1142 x 4240 x 210	
TRB 45P__SHLW	4500	2	980 x 4710 x 210	1142 x 4740 x 210	
TRB 50P__SHLW	5000	2	980 x 5210 x 210	1142 x 5240 x 210	
TRB 55P__SHLW	5500	2	980 x 5710 x 210	1142 x 5740 x 210	
TRB 60P__SHLW	6000	2	980 x 6210 x 210	1142 x 6240 x 210	

\* Different raising heights are optionally available.

<b>Axle Load Resistance</b>	40 t
<b>Hydraulic Cylinder Unit</b>	Dust sealed hydraulic cylinder, developed for heavy duty use. 1 - 3 m wide models contain single piston. 3,5 - 6,0 m wide models contain double pistons. Contains safety valve for hose bursts.
<b>Hydraulic Power Unit and Cabinet</b>	Strengthened industrial hydraulic pump. 40 - 120 lt capacity oil tank with magnetic metal collector and suction filter. Built-in oil level and oil temperature indicator. Standard 70 - 150 bar pressure (max. 180 bar). 10 m R2 type (double wire braided mesh) reinforced hydraulic hose.





Motor, hydraulic pump and solenoid valves are placed in an easily accessible galvanized and electrostatic powder coated steel cabinet with 2 built-in lock lids (opt. stainless steel cabinet).

Cabinet Type	Width (mm)	Length (mm)	Height (mm)
Cabinet 1	940	570	970
Cabinet 2	1040	590	1285
Cabinet 3	1243	840	1285

\*Suitable cabinet type is selected according to the preferred product configuration.

<b>System</b>	<p>Down, up, stop, emergency inputs and external sensor inputs/outputs (e.g. loop detector, safety sensor, traffic light, remote control, etc.). System alerts with an audio signal during lowering and raising operation. A loud siren alert in case of alarm or emergency. System stops in case of emergency as per default set-up and possible to be lowered or raised automatically (user's preference). Can be lowered and raised manually in case of power failure or during maintenance with manual pump (opt.) and manual valve feature. Automatic raise up mode deploys (available with optional loop detector) the road blocker after the vehicle has passed over. Sensor controlled stopping both at the top and bottom positions of the blocker unit. Free standing piston connection structure that does not put any load on the piston during vehicle passage and in case of an impact. Safety devices (if any, such as; safety sensor, loop detector, etc) are enabled in case fast raise up (EFO, optional) feature is activated and they can be optionally disabled.</p>	
<b>Blocker Unit (Underground Unit)</b>	<p>All parts are coloured with industrial paint with two components over anticorrosive primer application. Body is structured and strengthened with U-shaped beams. Product is designed that no vehicle crashing effect can displace it after embedded or installed in to the ground.</p>	
<b>Blocker Unit (Impact Blocking Unit)</b>	<p>Top plates (vehicle pass through surface) are hot dip galvanised and electrostatic powder coated. All other parts are coloured with industrial paint with two components over anticorrosive primer application. Moving parts are colored with RAL 1003 yellow (impact surface yellow-black) and fixed road surface plates in RAL 9005 black. In addition, the impact surface is finished with reflective signs and warnings. Bulge free hidden hinge structure below the ground level allows vehicles to pass over smoothly and quietly. Top panels where the vehicles pass over are made of 8/9 mm thick hot-dip galvanized steel with non-skid surface. The road blocker moves up and down as a block supported by Ø50 mm steel hinges at pivot points, which are welded on the main frame with wedges for extra strength. Number of hinges varies according to blocker width (3 m wide blocker contains 6 pieces of hinges). Impact blocker unit raises with 45° angle from the ground level. Impact blocking unit and the underground unit are connected with 6 sets (in 3 m long road blocker, varies according to road blocker width) of linkages in 2 pairs of 10 mm each fastened together by stainless steel shafts of 30 mm diameter. Front and side faces of the blocker unit are covered with decorative telescopic panels (opt.). A top lid integration is available for easy access to interior units for service and maintenance purposes.</p>	
<b>Control System</b>	<p>3 buttons for up, down and stop operations and 1 button for emergency stop are contained in a box that is suitable for outdoor use (optionally, 1 button for EFO-fast raise up). System stops its movement with the command from safety sensor (opt.) and loop detectors (opt.). Contains built-in LED indicators and 10 m cable. The system works with PLC as standard. Status of safety sensors (if any) and loop detectors (if any), position and movement of the blocker and low oil level situation of the system can be monitored with optional PLC with diagnostic display. Compatible with any access control system (by third parties).</p>	
<b>Power-off Situation</b>	<p>Road Blocker remains in its position in case of power-off. Optionally; can be lowered or raised and lowered by battery pack with 24V DC motor. Battery pack provides min.100 movements (50 deploy + 50 retract) when fully charged.</p>	
<b>Optional Features and Accessories</b>	<p>Telescopic front panels, hydraulic accumulator for EFO-fast raise up (1 piston or 2 pistons systems), hand pump for manual raising, 24V DC motor in case of power failure (50 deploy + 50 retract), oil heater (for oil tank), oil cooler, heater for electronic components, submersible pump, traffic light (Ø200/300 mm, red-green LED, electrostatic powder coated over 304 grade stainless steel body), traffic light pole (electrostatic powder coated over hot dip galvanised steel), loop detector (double contact), safety sensors (with 50 cm height poles), IP67 box (for PLC, SMPS, connectors etc inside power unit), wireless remote control (receiver and transmitter), external buttons, hot dip galvanization, double effect hydraulic unit, double speed hydraulic unit, PLC with diagnostic display, front flashing indicators, oil level sensor, ramp, different product dimensions.</p>	
<b>Installation</b>	<p>Installation with C35 grade concrete and steel rebar reinforcement. Ground levelling and preparation works shall be carried on before pouring the concrete. Allowable bearing value of the ground shall be minimum 1/2 kg/cm<sup>2</sup>, if not, works shall be carried on to fulfil. Installation shall be done according to the manufacturer's instructions.</p>	

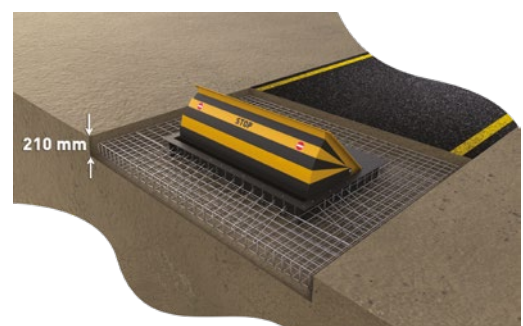

# General Technical Specifications

## (Shallow Mounted)

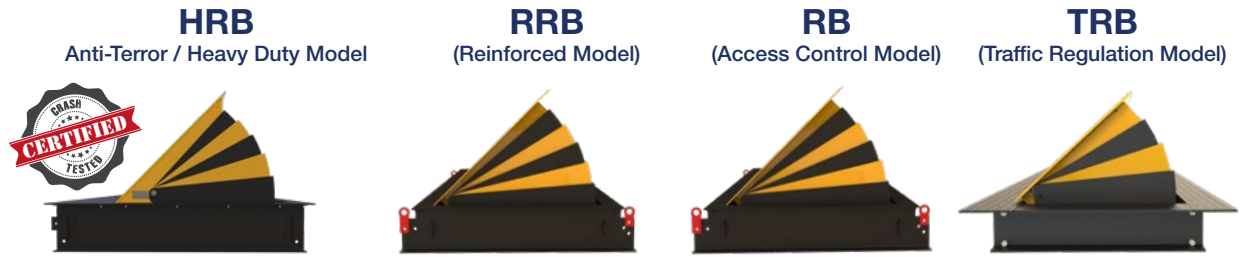

### General Specifications

Mounting Depth	400 mm	390 mm	290 mm	210 mm
<b>Crash/Impact Rating</b>	Crash tested and certified according to IWA 14-1:2013 Road Blocker/V/7200[N3C]/80, PAS68:2013 Road Blocker V/7500[N3]/80, and ASTM F2656-18 C750/7200 P1 (K-12) standards (HRB 30 P 90 SHLV).	Designed and produced to withstand impacts according to ASTM F2656 M, C7 (K-8), PAS68[N2 N3]/64 and IWA 14-1[N2A/N2B/N3C]/64 levels.	Designed and produced to withstand impacts according to ASTM F2656 M, C7 (K-4), PAS68[N2 N3]/48 and IWA 14-1[N2A/N2B/N3C]/48 levels.	-
<b>Axle Load Resistance</b>	50 t	50 t	40 t	40 t
<b>Impact Surface Thickness</b>	10 mm	6+5 mm	6 mm	5 mm
<b>Top Plate Thickness</b>	10/11 mm	8/9 mm	8/9 mm	8/9 mm
<b>Vertical Impact Absorbers</b>	8 mm solid panels	6 mm U beams	6 mm U beams	5 mm U beams
<b>Oil Level Sensor</b>	Standard	Optional	Optional	Optional
<b>Hand Pump for Manual Raising</b>	Standard	Standard	Standard	Optional
<b>Installation</b>	Installation with C30 grade concrete and steel rebars.	Installation with C35 grade concrete and steel rebars.	Installation with C35 grade concrete and steel rebars.	Installation with C35 grade concrete and steel rebars.
380V AC 3-phase, 50/60 Hz, 2,2 - 11 kW				
PLC control unit.				
24V DC control system.				
24V DC solenoids.				
~3 - 5 sec. raising speed (~1 - 1,5 sec. EFO with optional hydraulic accumulator, and may differ depending on road blocker dimensions for road blockers wider than 4,0 m).				
IP55 - Hydraulic Power Unit (optionally electronics control unit with IP67 protection box), IP68 - Hydraulic Piston				
-5°C / +55°C (opt. -30°C / +70°C) operating temperature.				
Safety valve for hose bursts.				
10 m R2 type (double wire braided mesh) hydraulic hose.				
40-120 lt capacity oil tank with magnetic metal collector and suction filter.				
Oil level and temperature indicator.				
Electrostatic powder coated over galvanised steel (opt. stainless steel) hydraulic power unit (HPU) cabinet				
External inputs/outputs (e.g. loop detector, safety sensor, traffic light, remote control, etc.).				
Audio signal during lowering and raising operation.				
Automatic / manual programmable passage authorisation (with optional loop detector).				
Manual lowering valve.				
Special design hinge system spread on overall width.				
Top plates (vehicle pass through surface) are hot dip galvanised and electrostatic powder coated anti skid steel. All other parts are coloured with industrial paint with two components.				
High resistant construction by welded, bolted and wedge type connection structure.				
Free standing piston connection structure avoiding load on the piston during vehicle passage and in case of an impact.				
Manual control button unit, that is suitable for outdoor use, with 3 functions.				
Emergency stop button.				
Reflective marking.				
Thanks to shallow installation depth no changes required in the existing underground infrastructure.				

### Optional Features and Accessories

Telescopic front panels, hydraulic accumulator for EFO-fast raise up (1 piston or 2 pistons systems), 24V DC motor in case of power failure (50 deploy + 50 retract), oil heater (for oil tank), oil cooler, heater for electronic components, submersible pump, traffic light (Ø200/300 mm, red-green LED, electrostatic powder coated over 304 grade stainless steel body), traffic light pole (electrostatic powder coated over hot dip galvanised steel), loop detector (double contact), safety sensors (with 50 cm height poles), IP67 box (for PLC, SMPS, connectors etc inside power unit), wireless remote control (receiver and transmitter), external buttons, hot dip galvanization, double effect hydraulic unit, double speed hydraulic unit, PLC with diagnostic display, front flashing indicators, oil level sensor, ramp, different product dimensions.









AT!  
NMEDE  
İNİZ.



## BOLLARDS

### RETRACTABLE (HYDRAULIC) BOLLARDS

#### 62 DEEP EXCAVATED SERIES

62 HBD/12 (ANTI-TERROR / HEAVY DUTY - RETRACTABLE MODEL)

66 HBD/8 (ANTI-TERROR / HEAVY DUTY - RETRACTABLE MODEL)

70 RBD/4 (REINFORCED - RETRACTABLE MODEL)

76 TBD (TRAFFIC REGULATION - RETRACTABLE MODEL)

80 GENERAL TECHNICAL SPECIFICATIONS (RETRACTABLE MODELS)

#### 81 FIXED (STATIC) BOLLARDS

#### 82 DEEP EXCAVATED SERIES

82 HBD/12 (ANTI-TERROR / HEAVY DUTY - FIXED MODEL)

83 HBD/8 (ANTI-TERROR / HEAVY DUTY - FIXED MODEL)

84 RBD/4 (REINFORCED - FIXED MODEL)

#### 85 SHALLOW MOUNT SERIES

86 HBD/12 SHLW (ANTI-TERROR / HEAVY DUTY - FIXED - SHALLOW MOUNT MODEL)

87 HBD/8 SHLW (ANTI-TERROR / HEAVY DUTY - FIXED - SHALLOW MOUNT MODEL)

90 RBD/4 SHLW (REINFORCED - FIXED - SHALLOW MOUNT MODEL)

#### 91 TRAFFIC REGULATION SERIES

92 TBD (TRAFFIC REGULATION - FIXED MODEL)

#### 93 REMOVABLE BOLLARDS

94 TBD RMB REMOVABLE BOLLARD







M40 Installation





**M40 (K8)**  
**ASTM 2656-07**



for crash  
test video



max. penetr  
fo  
(1 mt





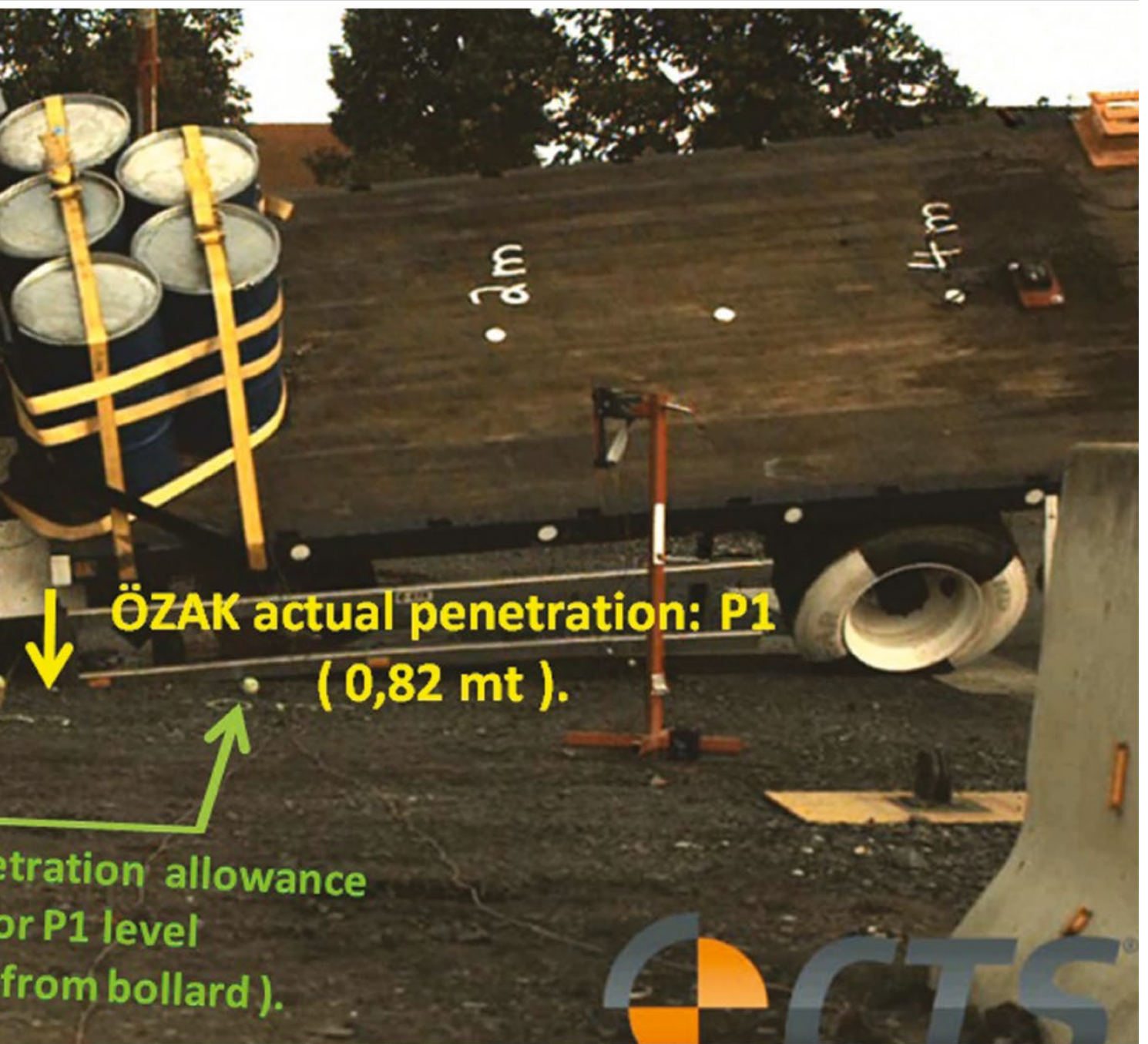





## M50 Installation





# HBD/12 BOLLARD

(Anti-terror / Heavy Duty - Retractable Model)

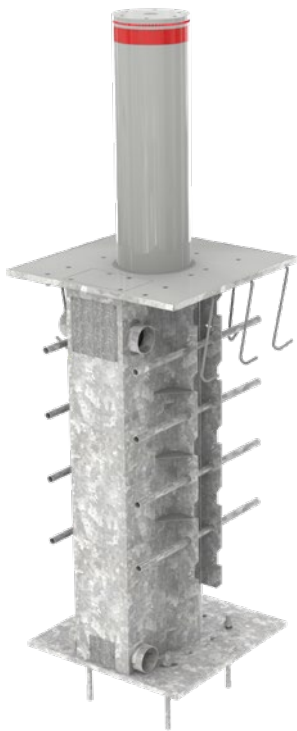

**M50 (K-12)**  
**ASTM F2656-07**



## Dimensions (mm)

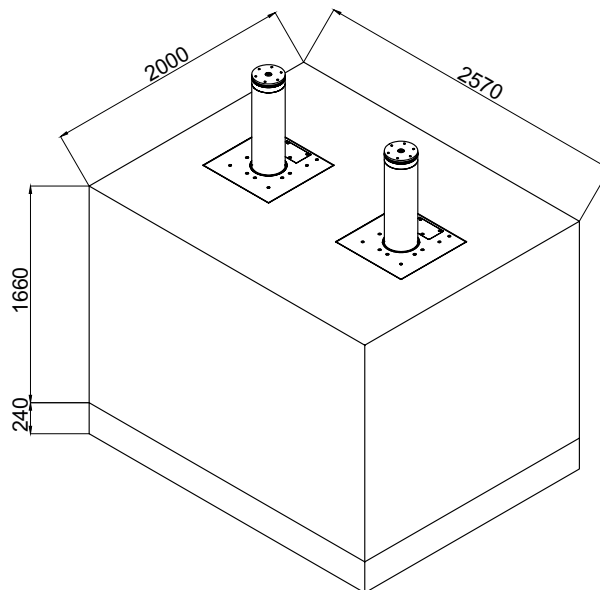
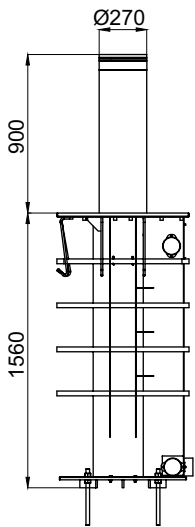

\* Different raising heights are optionally available.

## Technical Features

<b>Power</b>	Standard 380V AC 3-Phase 50/60 Hz, 1,1 - 11 kW motor (varies depending on the number of bollards in the set to be fed and the accessories to be included). Operating with 24V DC in case of power failure is optionally available.
<b>Control Pack</b>	24V DC powered PLC control unit is placed in power unit cabinet. 24V DC (opt. 12V DC / 220V AC) solenoids.
<b>Speed</b>	Standard operation ~2,5 - 6 sec. (ascend/descend) depending on the number of bollards in the set to be fed. Fast raise up (EFO, by optional hydraulic accumulator) ~1 - 1,5 sec. and may differ depending on the number of bollards in the set and the raising height.
<b>IP Rating</b>	IP55 - Hydraulic Power Unit (optionally electronics control unit with IP67 protection box) IP68 - Hydraulic Piston
<b>Operating Temperature</b>	-5°C / +55°C (opt. -30°C / +70°C)



**Crash / Impact Rating** Crash tested and certified according to ASTM F2656-07 at M50 (K-12) level (HBD 275 H 90). In addition, designed and produced to withstand impacts mentioned below:

Standard	Vehicle Type	Weight	Speed
PAS 68	N3	7500 kg	80 km/h (50 mph)
IWA 14-1	N3C	7200 kg	80 km/h (50 mph)

(Please contact for applicable product dimensions)

**Axle Load Resistance** 70 t

**Hydraulic Cylinder Unit** Dust sealed, double effect hydraulic cylinder, developed for heavy duty use.

**Hydraulic Power Unit and Cabinet:** Strengthened industrial hydraulic pump.  
40 - 120 lt (depending on the number of bollards to be fed and the raising height) capacity oil tank with magnetic metal collector and suction filter.  
Built-in oil level indicator and sensor, oil temperature indicator and audio alarm feature for low oil level.  
Standard 60 - 120 bar pressure (depending on the number of bollards to be fed, max. 160 bar, ).  
10 m R2 type (double wire braided mesh) reinforced hydraulic hose.  
Interconnecting hoses in case of installations of multiple bollard posts.



Motor, hydraulic pump and solenoid valves are placed in an easily accessible galvanized and electrostatic powder coated steel cabinet with 2 built-in lock lids (opt. stainless steel cabinet).

Cabinet Type	Width (mm)	Length (mm)	Height (mm)
Cabinet 1	940	570	970
Cabinet 2	1040	590	1285
Cabinet 3	1243	840	1285

\*Suitable cabinet type is selected according to the preferred product configuration.

**System** Down, up, stop, emergency inputs and external sensor inputs/outputs (e.g. loop detector, safety sensor, traffic light, remote control, etc.).  
System alerts with an audio signal during lowering and raising operation. A loud siren alert in case of alarm or emergency.  
System stops in case of emergency as per default set-up and possible to be lowered or raised automatically (user's preference).  
Can be lowered and raised manually in case of power failure or during maintenance with manual pump and manual valve feature.  
Automatic raise up mode deploys (available with optional loop detector) the bollard after the vehicle has passed over.  
Contains IP67 magnetic sensor for barrier position and traffic signalisation.  
Free standing piston connection structure that does not put any load on the piston during vehicle passage.  
Equipped with absorbing spring system for bumping at top point.  
Safety devices (if any, such as; safety sensor, loop detector, etc) are enabled in case fast raise up (EFO, optional) feature is activated and they can be optionally disabled.

**Bollard Unit (Underground Unit)** **Bollard Anchorage Casing:**  
Ø338 mm hot dip galvanised steel, designed so that no vehicle crashing effect can displace it after embedded into the ground.  
Left and right hydraulic hose and cable entry openings use both directions as per HPU position and site conditions.  
Contains connection for rainwater drainage.  
Easy installation with ground mounting plate by bolting to the base foundation. Easy access to hydraulic hose and cables is provided.

**Bollard Main Housing:**  
Ø324 mm hot dip galvanised steel structured to provide main housing for the bollard cylinder.  
Bollard cylinder is pivoted with and moves through 5 rails (inner railing) placed on the main housing with equal distances from each other for maximum rigidity and minimum material fraction.  
Contains the hydraulic cylinder lower connection.

**Bollard Unit (Impact Blocking Unit)** **Bollard Cylinder (Crash Unit):**  
Ø270 mm crash surface made of hot-dip galvanised steel pipe with 10 mm wall thickness electrostatic powder coated in RAL9006 as standard (other RAL colors or 304 - 316 grade stainless steel sleeve are optionally available) and infilled with eccentrically 65 - 90 mm thick solid steel and composite material.  
Special star-formed, 10 mm solid steel bar infilled inner structure for impact absorption distributed evenly to the whole body.  
Demountable, RAL 9006 electrostatic powder coated aluminium bollard top lid with 360° visible red flashing LED indicators.  
Furnished with red (opt. white or yellow) reflecting strips.  
Bollard cylinder pivoted with and moves through replaceable 5 special non-metal rails (outer railing) positioned with equal distances from each other for maximum rigidity and minimum material fraction.  
Contains the hydraulic cylinder upper connection.  
Thanks to the bollard anchorage casing, bollard cylinder is designed to be replaced together with the main housing in case of a crash damage.

**Road Surface Plate:**  
15 mm steel, hot-dip galvanised and electrostatic powder coated in RAL9006 (other RAL colors are optionally available). Easy disassembly by its bolt type connection.  
Also contains the dust sealant / wiper seal.

# HBD/12 BOLLARD (Anti-terror / Heavy Duty - Retractable Model)

<b>Control System</b>	<p>3 buttons for up, down and stop operations and 1 button for emergency stop are contained in a box that is suitable for outdoor use that is suitable for outdoor use (optionally, 1 button for EFO-fast raise up). Contains built-in LED indicators and 10 m cable. System stops its movement with the command from safety sensor (opt.) and loop detectors (opt.). The system works with PLC as standard. Status of safety sensors (if any) and loop detectors (if any), position and movement of the blocker and low oil level situation of the system can be monitored with optional PLC with diagnostic display. Compatible with any access control system (by third parties).</p>	
<b>Power-off Situation</b>	<p>Bollard remains in its position in case of power-off. Optionally; can be lowered or raised and lowered by battery pack with 24V DC motor. Battery pack provides min.60-100 movements when fully charged (minimum number of movements vary depending on the number of bollards in the set to be fed).</p>	
<b>Optional Features and Accessories</b>	<p>Hydraulic accumulator for EFO-fast raise up, 24V DC motor in case of power failure (min. 60 - 100 movements), oil heater (for oil tank), oil cooler, heater for electronic components, submersible pump, traffic light (Ø200/300 mm, red-green LED, electrostatic powder coated over 304 grade stainless steel body), traffic light pole (electrostatic powder coated over hot dip galvanised steel), loop detector (double contact), safety sensors (with 50 cm height poles), IP67 box (for PLC, SMPS, connectors etc inside power unit), wireless remote control (receiver and transmitter), external buttons, PLC with diagnostic display, different product dimensions, 304 - 316 grade stainless steel sleeve.</p>	
<b>Installation</b>	<p>Installation with C30 grade concrete and steel rebar reinforcement. Ground levelling and preparation works shall be carried on before pouring the concrete. Allowable bearing value of the ground shall be minimum 1/2 kg/cm<sup>2</sup>, if not, works shall be carried on to fulfil. Installation shall be done according to the manufacturer's instructions. Possible to install multiple bollard posts controlled by a single hydraulic power unit (HPU). Minimum 2 bollard posts shall be installed for M50 certificate compliance.</p>	







DİKKAT!  
BARIYER INMEDEN  
GEÇMEYİNİZ.



# HBD/8 BOLLARD

(Anti-terror / Heavy Duty - Retractable Model)



**M40 (K-8)**  
**ASTM F2656-07**

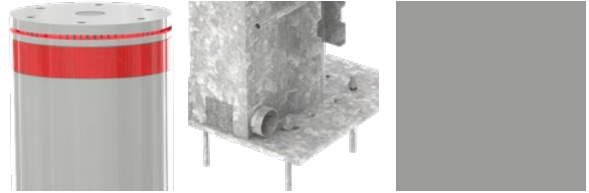

## Dimensions (mm)

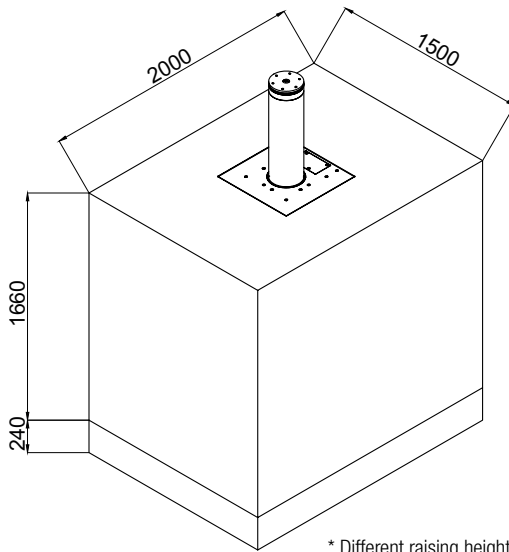
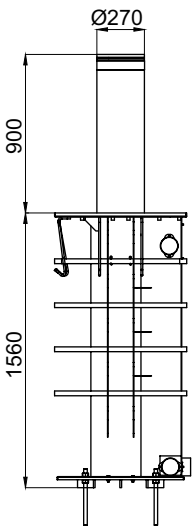

\* Different raising heights are optionally available.

## Technical Features

<b>Power</b>	Standard 380V AC 3-Phase 50/60 Hz, 1,1 - 11 kW motor (varies depending on the number of bollards in the set to be fed and the accessories to be included). Operating with 24V DC in case of power failure is optionally available.
<b>Control Pack</b>	24V DC powered PLC control unit is placed in power unit cabinet. 24V DC (opt.12V DC / 220V AC) solenoids.
<b>Speed</b>	Standard operation ~2,5 - 6 sec. (ascend/descend) depending on the number of bollards in the set to be fed. Fast raise up (EFO, by optional hydraulic accumulator) ~1 - 1,5 sec. and may differ depending on the number of bollards in the set and the raising height.
<b>IP Rating</b>	IP55 - Hydraulic Power Unit (optionally electronics control unit with IP67 protection box) IP68 - Hydraulic Piston
<b>Operating Temperature</b>	-5°C / +55°C (opt. -30°C / +70°C)



**Crash / Impact Rating** Crash tested and certified according to ASTM F2656-07 at M40 (K-8) level (HBD 275 H 90). In addition, designed and produced to withstand impacts mentioned below:

Standard	Vehicle Type	Weight	Speed
PAS 68	N3	7500 kg	64 km/h (40 mph)
IWA 14-1	N3C	7200 kg	64 km/h (40 mph)

(Please contact for applicable product dimensions).

**Axle Load Resistance** 70 t

**Hydraulic Cylinder Unit** Dust sealed, double effect hydraulic cylinder, developed for heavy duty use.

**Hydraulic Power Unit and Cabinet:** Strengthened industrial hydraulic pump.  
40 - 120 lt (depending on the number of bollards to be fed and the raising height) capacity oil tank with magnetic metal collector and suction filter.  
Built-in oil level indicator and sensor, oil temperature indicator and audio alarm feature for low oil level.  
Standard 60 - 120 bar pressure (depending on the number of bollards to be fed, max. 160 bar, ).  
10 m R2 type (double wire braided mesh) reinforced hydraulic hose.  
Interconnecting hoses in case of installations of multiple bollard posts.



Motor, hydraulic pump and solenoid valves are placed in an easily accessible galvanized and electrostatic powder coated steel cabinet with 2 built-in lock lids (opt. stainless steel cabinet).

Cabinet Type	Width (mm)	Length (mm)	Height (mm)
Cabinet 1	940	570	970
Cabinet 2	1040	590	1285
Cabinet 3	1243	840	1285

\* Suitable cabinet type is selected according to the preferred product configuration.

**System** Down, up, stop, emergency inputs and external sensor inputs/outputs (e.g. loop detector, safety sensor, traffic light, remote control, etc.). System alerts with an audio signal during lowering and raising operation. A loud siren alert in case of alarm or emergency. System stops in case of emergency as per default set-up and possible to be lowered or raised automatically (user's preference). Can be lowered and raised manually in case of power failure or during maintenance with manual pump and manual valve feature. Automatic raise up mode deploys (available with optional loop detector) the bollard after the vehicle has passed over. Contains IP67 magnetic sensor for barrier position and traffic signalisation. Free standing piston connection structure that does not put any load on the piston during vehicle passage. Equipped with absorbing spring system for bumping at top point. Safety devices (if any, such as; safety sensor, loop detector, etc) are enabled in case fast raise up (EFO, optional) feature is activated and they can be optionally disabled.

**Bollard Unit (Underground Unit)** **Bollard Anchorage Casing:**  
Ø338 mm hot dip galvanised steel, designed so that no vehicle crashing effect can displace it after embedded into the ground. Left and right hydraulic hose and cable entry openings to use both directions as per HPU position and site conditions. Contains connection for rainwater drainage. Easy installation with ground mounting plate by bolting to the base foundation. Easy access to hydraulic hose and cables is provided.

**Bollard Main Housing:**  
Ø324 mm hot dip galvanised steel structured to provide main housing for the bollard cylinder. Bollard cylinder is pivoted with and moves through 5 rails (inner railing) placed on the main housing with equal distances from each other for maximum rigidity and minimum material fraction. Contains the hydraulic cylinder lower connection.

**Bollard Unit (Impact Blocking Unit)** **Bollard Cylinder (Crash Unit):**  
Ø270 mm crash surface made of hot-dip galvanised steel pipe with 10 mm wall thickness electrostatic powder coated in RAL9006 as standard (other RAL colors or 304 - 316 grade stainless steel sleeve are optionally available) and infilled with eccentrically 65 - 90 mm thick solid steel and composite material. Special star-formed, 10 mm solid steel bar infilled inner structure for impact absorption distributed evenly to the whole body. Demountable, RAL 9006 electrostatic powder coated aluminium bollard top lid with 360° visible red flashing LED indicators. Furnished with red (opt. white or yellow) reflecting strips. Bollard cylinder pivoted with and moves through replaceable 5 special non-metal rails (outer railing) positioned with equal distances from each other for maximum rigidity and minimum material fraction. Contains the hydraulic cylinder upper connection. Thanks to the bollard anchorage casing, bollard cylinder is designed to be replaced together with the main housing in case of a crash damage.

**Road Surface Plate:**  
15 mm steel, hot-dip galvanised and electrostatic powder coated in RAL9006 (other RAL colors are optionally available). Easy disassembly by its bolt type connection. Also contains the dust sealant / wiper seal.

# HBD/8 BOLLARD (Anti-terror / Heavy Duty - Retractable Model)

<b>Control System</b>	<p>3 buttons for up, down and stop operations and 1 button for emergency stop are contained in a box that is suitable for outdoor use (optionally, 1 button for EFO-fast raise up). Contains built-in LED indicators and 10 m cable. System stops its movement with the command from safety sensor (opt.) and loop detectors (opt.). The system works with PLC as standard. Status of safety sensors (if any) and loop detectors (if any), position and movement of the blocker and low oil level situation of the system can be monitored with optional PLC with diagnostic display. Compatible with any access control system (by third parties).</p>	
<b>Power-off Situation</b>	<p>Bollard remains in its position in case of power-off. Optionally; can be lowered or raised and lowered by battery pack with 24V DC motor. Battery pack provides min.60-100 movements when fully charged (minimum number of movements vary depending on the number of bollards in the set to be fed).</p>	
<b>Optional Features and Accessories</b>	<p>Hydraulic accumulator for EFO-fast raise up, 24V DC motor in case of power failure (min. 60 - 100 movements), oil heater (for oil tank), oil cooler, heater for electronic components, submersible pump, traffic light (Ø200/300 mm, red-green LED, electrostatic powder coated over 304 grade stainless steel body), traffic light pole (electrostatic powder coated over hot dip galvanised steel), loop detector (double contact), safety sensors (with 50 cm height poles), IP67 box (for PLC, SMPS, connectors etc inside power unit), wireless remote control (receiver and transmitter), external buttons, PLC with diagnostic display, different product dimensions, 304 - 316 grade stainless steel sleeve.</p>	
<b>Installation</b>	<p>Installation with C30 grade concrete and steel rebar reinforcement. Ground levelling and preparation works shall be carried on before pouring the concrete. Allowable bearing value of the ground shall be minimum 1/2 kg/cm<sup>2</sup>, if not, works shall be carried on to fulfil. Installation shall be done according to the manufacturer's instructions. Possible to install multiple bollard posts controlled by a single hydraulic power unit (HPU). 1200 mm gap between bollard posts in multiple unit installations is recommended.</p>	







TEKFENTOWER

# RBD/4 BOLLARD

(Reinforced - Retractable Model)



## Dimensions (mm)

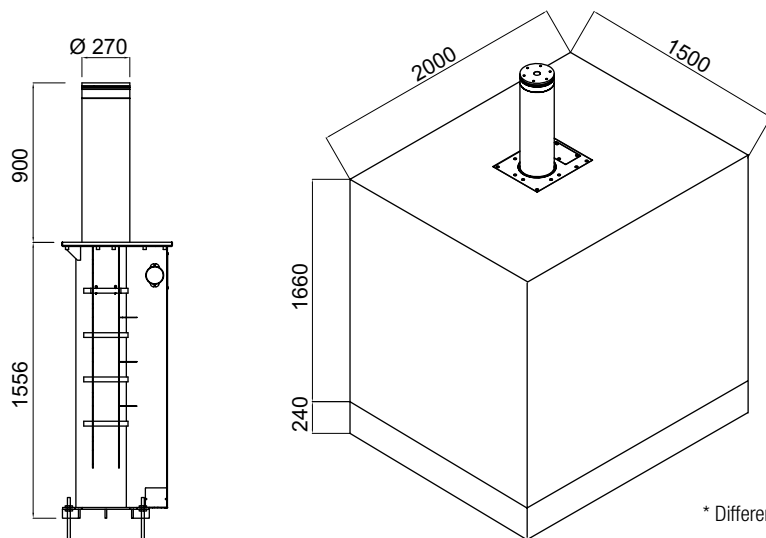

\* Different raising heights are optionally available.

## Technical Features

<b>Power</b>	Standard 380V AC 3-Phase 50/60 Hz, 1,1 - 11 kW motor (varies depending on the number of bollards in the set to be fed and the accessories to be included). Operating with 24V DC in case of power failure is optionally available.
<b>Control Pack</b>	24V DC powered PLC control unit is placed in power unit cabinet. 24V DC (opt. 12V DC / 220V AC) solenoids.
<b>Speed</b>	Standard operation ~2,5 - 6 sec. (ascend/descend) depending on the number of bollards in the set to be fed. Fast raise up (EFO, by optional hydraulic accumulator) ~1 - 1,5 sec. and may differ depending on the number of bollards in the set and the raising height.
<b>IP Rating</b>	IP55 - Hydraulic Power Unit (optionally electronics control unit with IP67 protection box) IP68 - Hydraulic Piston
<b>Operating Temperature</b>	-5°C / +55°C (opt. -30°C / +70°C)



**Crash / Impact Rating** Designed and produced to withstand impacts mentioned below:

Standard	Vehicle Type	Weight	Speed
ASTM F2656	M, C7 (K-4)	6800, 7200 kg	48 km/h (30 mph)
PAS 68	N3	7500 kg	48 km/h (30 mph)
IWA 14-1	N3C	7200 kg	48 km/h (30 mph)

Please contact for applicable product dimensions.

**Axle Load Resistance** 50 t

**Hydraulic Cylinder Unit** Dust sealed, double effect hydraulic cylinder, developed for heavy duty use.

**Hydraulic Power Unit and Cabinet** Strengthened industrial hydraulic pump.  
 40 - 120 lt (depending on the number of bollards to be fed and the raising height) capacity oil tank with magnetic metal collector and suction filter.  
 Built-in oil level and oil temperature indicator.  
 Standard 60 - 120 bar pressure (depending on the number of bollards to be fed, max. 160 bar, ).  
 10 m R2 type (double wire braided mesh) reinforced hydraulic hose.  
 Interconnecting hoses in case of installations of multiple bollard posts.



Motor, hydraulic pump and solenoid valves are placed in an easily accessible galvanized and electrostatic powder coated steel cabinet with 2 built-in lock lids (opt. stainless steel cabinet).

Cabinet Type	Width (mm)	Length (mm)	Height (mm)
Cabinet 1	940	570	970
Cabinet 2	1040	590	1285
Cabinet 3	1243	840	1285

\* Suitable cabinet type is selected according to the preferred product configuration.

**System** Down, up, stop, emergency inputs and external sensor inputs/outputs (e.g. loop detector, safety sensor, traffic light, remote control, etc.).  
 System alerts with an audio signal during lowering and raising operation. A loud siren alert in case of alarm or emergency.  
 System stops in case of emergency as per default set-up and possible to be lowered or raised automatically (user's preference).  
 Can be lowered and raised manually in case of power failure or during maintenance with manual pump and manual valve feature.  
 Automatic raise up mode deploys (available with optional loop detector) the bollard after the vehicle has passed over.  
 Contains IP67 magnetic sensor for barrier position and traffic signalisation.  
 Free standing piston connection structure that does not put any load on the piston during vehicle passage.  
 Equipped with absorbing spring system for bumping at top point.  
 Safety devices (if any, such as; safety sensor, loop detector, etc) are enabled in case fast raise up (EFO, optional) feature is activated and they can be optionally disabled.

**Bollard Unit (Underground Unit)** **Bollard Anchorage Casing:**  
 Ø338 mm hot dip galvanised steel, designed so that no vehicle crashing effect can displace it after embedded into the ground.  
 Left and right hydraulic hose and cable entry openings to use both directions as per HPU position and site conditions.  
 Contains connection for rainwater drainage.  
 Easy installation with ground mounting plate by bolting to the base foundation. Easy access to hydraulic hose and cables is provided.

**Bollard Main Housing:**  
 Ø324 mm hot dip galvanised steel structured to provide main housing for the bollard cylinder.  
 Bollard cylinder is pivoted with and moves through 5 rails (inner railing) placed on the main housing with equal distances from each other for maximum rigidity and minimum material fraction.  
 Contains the hydraulic cylinder lower connection.

**Bollard Unit (Impact Blocking Unit)** **Bollard Cylinder (Crash Unit):**  
 Ø270 mm crash surface made of hot-dip galvanised steel pipe with 8 mm wall thickness electrostatic powder coated in RAL9006 as standard (other RAL colors or 304 - 316 grade stainless steel sleeve are optionally available) and infilled with eccentrically 65 - 90 mm thick solid steel.  
 Special star-formed, 5 mm solid steel bar infilled inner structure for impact absorption distributed evenly to the whole body.  
 Demountable, RAL 9006 electrostatic powder coated aluminium bollard top lid with 360° visible red flashing LED indicators.  
 Furnished with red (opt. white or yellow) reflecting strips.  
 Bollard cylinder pivoted with and moves through replaceable 5 special non-metal rails (outer railing) positioned with equal distances from each other for maximum rigidity and minimum material fraction.  
 Contains the hydraulic cylinder upper connection.  
 Thanks to the bollard anchorage casing, bollard cylinder is designed to be replaced together with the main housing in case of a crash damage.

**Road Surface Plate:**  
 15 mm steel, hot-dip galvanised and electrostatic powder coated in RAL9006 (other RAL colors are optionally available). Easy disassembly by its bolt type connection.  
 Also contains the dust sealant / wiper seal.

# RBD/4 BOLLARD (Reinforced - Retractable Model)

<b>Control System</b>	<p>3 buttons for up, down and stop operations and 1 button for emergency stop are contained in a box that is suitable for outdoor use (optionally, 1 button for EFO-fast raise up). Contains built-in LED indicators and 10 m cable. System stops its movement with the command from safety sensor (opt.) and loop detectors (opt.). The system works with PLC as standard. Status of safety sensors (if any) and loop detectors (if any), position and movement of the blocker and low oil level situation of the system can be monitored with optional PLC with diagnostic display. Compatible with any access control system (by third parties).</p>	
<b>Power-off Situation</b>	<p>Bollard remains in its position in case of power-off. Optionally; can be lowered or raised and lowered by battery pack with 24V DC motor. Battery pack provides min.60-100 movements when fully charged (minimum number of movements vary depending on the number of bollards in the set to be fed).</p>	
<b>Optional Features and Accessories</b>	<p>Hydraulic accumulator for EFO-fast raise up, 24V DC motor in case of power failure (min. 60 - 100 movements), oil heater (for oil tank), oil cooler, heater for electronic components, submersible pump, traffic light (Ø200/300 mm, red-green LED, electrostatic powder coated over 304 grade stainless steel body), traffic light pole (electrostatic powder coated over hot dip galvanised steel), loop detector (double contact), safety sensors (with 50 cm height poles), IP67 box (for PLC, SMPS, connectors etc inside power unit), wireless remote control (receiver and transmitter), external buttons, PLC with diagnostic display, oil level sensor, different product dimensions, 304 - 316 grade stainless steel sleeve.</p>	
<b>Installation</b>	<p>Installation with C30 grade concrete and steel rebar reinforcement. Ground levelling and preparation works shall be carried on before pouring the concrete. Allowable bearing value of the ground shall be minimum 1/2 kg/cm<sup>2</sup>, if not, works shall be carried on to fulfil. Installation shall be done according to the manufacturer's instructions. Possible to install multiple bollard posts controlled by a single hydraulic power unit (HPU). 1200 mm gap between bollard posts in multiple unit installations is recommended.</p>	

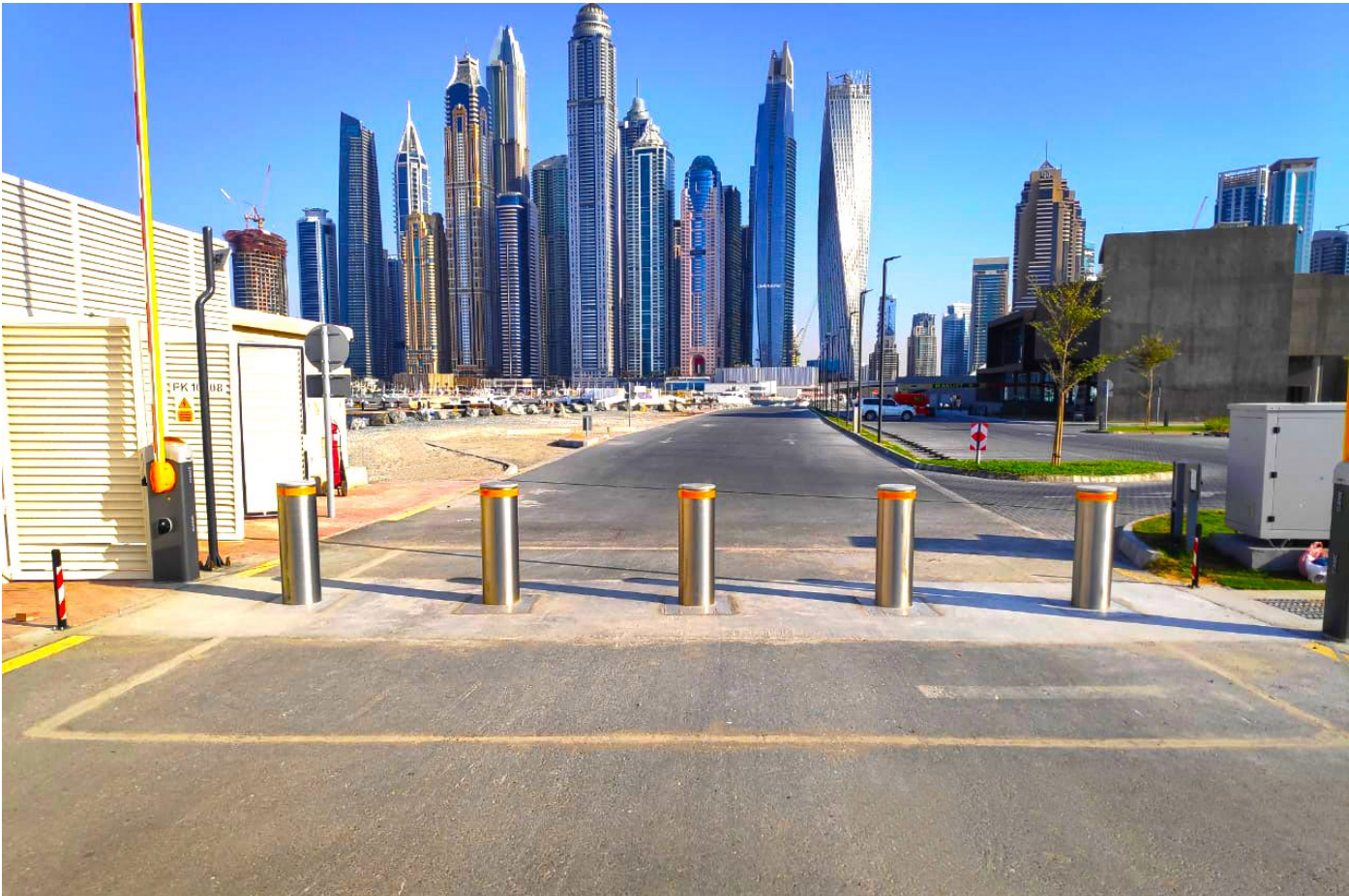













- ↳ ENTRY HOUSE
- ↳ DROP OFF
- ↳ PARKING
- ↳ GROUP CHECK IN
- ↳ ASSEMBLY POINT





# TBD BOLLARD

(Traffic Regulation - Retractable Model)

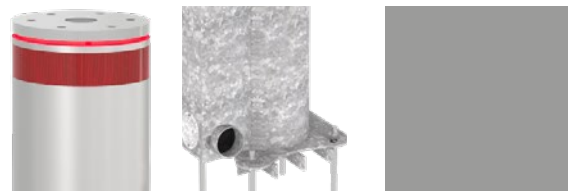

## Dimensions (mm)

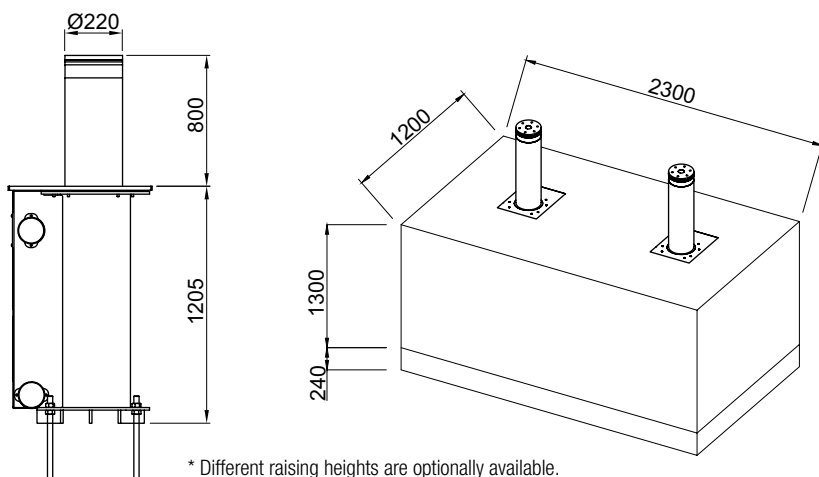

\* Different raising heights are optionally available.

## Technical Features

<b>Power</b>	Standard 380V AC 3-Phase 50/60 Hz, 1,1 - 11 kW motor (varies depending on the number of bollards in the set to be fed and the accessories to be included). Operating with 24V DC in case of power failure is optionally available
<b>Control Pack</b>	24V DC powered ÖZAK PLC control unit is placed in power unit cabinet. 24V DC (opt.12V DC / 220V AC) solenoids
<b>Speed</b>	Standard operation ~3 - 6 sec. (ascend/descend) depending on the number of bollards in the set to be fed. Fast raise up (EFO, by optional hydraulic accumulator) ~1 - 1,5 sec. and may differ depending on the number of bollards in the set and the raising height.
<b>IP Rating</b>	IP55 - Hydraulic Power Unit (optionally electronics control unit with IP67 protection box) IP68 - Hydraulic Piston
<b>Operating Temperature</b>	-5°C / +55°C (opt. -30°C / +70°C)
<b>Crash / Impact Rating</b>	-
<b>Axle Load Resistance</b>	40 t
<b>Hydraulic Cylinder Unit</b>	Dust sealed, double effect hydraulic cylinder, developed for heavy duty use.
<b>Hydraulic Power Unit and Cabinet</b>	Strengthened industrial hydraulic pump. 40 - 120 lt (depending on the number of bollards to be fed and the raising height) capacity oil tank with magnetic metal collector and suction filter. Built-in oil level and oil temperature indicator. Standard 55 - 120 bar pressure (depending on the number of bollards to be fed, max. 160 bar, ).





10 m R2 type (double wire braided mesh) reinforced hydraulic hose.  
Interconnecting hoses in case of installations of multiple bollard posts.

Motor, hydraulic pump and solenoid valves are placed in an easily accessible galvanized and electrostatic powder coated steel cabinet with 2 built-in lock lids (opt. stainless steel cabinet).

Cabinet Type	Width (mm)	Length (mm)	Height (mm)
Cabinet 1	940	570	970
Cabinet 2	1040	590	1285
Cabinet 3	1243	840	1285

\* Suitable cabinet type is selected according to the preferred product configuration.

<b>System</b>	<p>Down, up, stop, emergency inputs and external sensor inputs/outputs (e.g. loop detector, safety sensor, traffic light, remote control, etc.). System alerts with an audio signal during lowering and raising operation. A loud siren alert in case of alarm or emergency. System stops in case of emergency as per default set-up and possible to be lowered or raised automatically (user's preference). Can be lowered and raised manually in case of power failure or during maintenance with manual pump (opt.) and manual valve feature. Automatic raise up mode deploys (available with optional loop detector) the bollard after the vehicle has passed over. Contains IP67 magnetic sensor for barrier position and traffic signalisation. Free standing piston connection structure that does not put any load on the piston during vehicle passage. Safety devices (if any, such as; safety sensor, loop detector, etc) are enabled in case fast raise up (EFO, optional) feature is activated and they can be optionally disabled.</p>
<b>Bollard Unit (Underground Unit)</b>	<p><b>Bollard Anchorage Casing:</b> Ø267 mm hot dip galvanised steel, designed so that no vehicle crashing effect can displace it after embedded into the ground. Left and right hydraulic hose and cable entry openings to use both directions as per HPU position and site conditions. Contains connection for rainwater drainage. Easy installation with ground mounting plate by bolting to the base foundation. Easy access to hydraulic hose and cables is provided.</p> <p>Bollard cylinder is pivoted with and moves through 3 rails (inner railing) placed on the anchorage casing with equal distances from each other for maximum rigidity and minimum material fraction. Contains the hydraulic cylinder lower connection.</p>
<b>Bollard Unit (Impact Blocking Unit)</b>	<p><b>Bollard Cylinder (Crash Unit):</b> Ø220 mm crash surface made stainless steel sleeve on of hot-dip galvanised steel pipe with 6 mm wall thickness. Demountable, RAL 9006 electrostatic powder coated aluminium bollard top lid with 360° visible red flashing LED indicators. Furnished with red (opt. white or yellow) reflecting strips. Bollard cylinder is pivoted with and moves through 3 rails (outer railing) placed on the anchorage casing with equal distances from each other for maximum rigidity and minimum material fraction. Contains the hydraulic cylinder upper connection. Bollard cylinder is designed to be replaced in case of a crash damage.</p> <p><b>Road Surface Plate:</b> 15 mm steel, hot-dip galvanised and electrostatic powder coated in RAL9006 (other RAL colors are optionally available). Easy disassembly by its bolt type connection. Also contains the dust sealant / wiper seal.</p>
<b>Control System</b>	<p>3 buttons for up, down and stop operations and 1 button for emergency stop are contained in a box that is suitable for outdoor use (optionally, 1 button for EFO-fast raise up). Contains built-in LED indicators and 10 m cable. System stops its movement with the command from safety sensor (opt.) and loop detectors (opt.). The system works with ÖZAK PLC as standard. Compatible with any access control system (by third parties).</p>
<b>Power-off Situation</b>	<p>Bollard remains in its position in case of power-off. Optionally; can be lowered or raised and lowered by battery pack with 24V DC motor. Battery pack provides min.60-100 movements when fully charged (minimum number of movements vary depending on the number of bollards in the set to be fed).</p>
<b>Optional Features and Accessories</b>	<p>Hydraulic accumulator for EFO-fast raise up, hand pump for manual raising, 24V DC motor in case of power failure (min. 60 – 100 movements), oil heater (for oil tank), oil cooler, heater for electronic components, submersible pump, traffic light (Ø200/300 mm, red-green LED, electrostatic powder coated over 304 grade stainless steel body), traffic light pole (electrostatic powder coated over hot dip galvanised steel), loop detector (double contact), safety sensors (with 50 cm height poles), IP67 box (for ÖZAK PLC, SMPS, connectors etc inside power unit), wireless remote control (receiver and transmitter), external buttons, oil level sensor, different product dimensions.</p>
<b>Installation</b>	<p>Installation with C30 grade concrete and steel rebar reinforcement. Ground levelling and preparation works shall be carried on before pouring the concrete. Allowable bearing value of the ground shall be minimum 1/2 kg/cm<sup>2</sup>, if not, works shall be carried on to fulfil. Installation shall be done according to the manufacturer's instructions. Possible to install multiple bollard posts controlled by a single hydraulic power unit (HPU).</p>













# General Technical Specifications

**HBD**  
(Anti-Terror / Heavy Duty Model)



**RBD**  
(Reinforced Model)



**TBD**  
(Traffic Regulation Model)



## General Specifications

<b>Crash/Impact Rating</b>	Crash tested and certified according to ASTM F2656-07 at M50 (K-12) and M40 (K-8) levels (HBD 275 H 90) and also designed and produced to withstand impacts according to PAS68[N2/N3]/80 and 64 km/h and IWA 14-1[N2A/N2B/N3C]/80 and 64 km/h levels.	Designed and produced to withstand impacts according to ASTM F2656 M30, C730 (K-4), PAS68[N2/N3]/48 and IWA 14-1[N2A/N2B/N3C]/48 levels.	-
<b>Axle Load Resistance</b>	70 t	50 t	40 t
<b>Crash Unit Wall Thickness</b>	10 mm + 65/90 mm eccentric special star formed solid panels of 10 mm thickness and composite filling.	8 mm + 65/90 mm eccentric special star formed solid panels of 5 mm thickness.	6 mm
<b>Impact Surface Specification</b>	Electrostatic powder coated over hot dip galvanisation.	Electrostatic powder coated over hot dip galvanisation.	Stainless steel sleeve.
<b>Ground Mounting Support Rods</b>	Standard	Standard	-
<b>Oil Level Sensor</b>	Standard	Optional	Optional
<b>Hand Pump for Manual Raising</b>	Standard	Standard	Optional
<b>Speed</b>	2,5 - 6 sec.	2,5 - 6 sec.	3 - 6 sec.
<b>Control System</b>	PLC control unit.	PLC control unit.	ÖZAK PLC control unit.
380V AC 3-phase, 50/60 Hz, 1,1 - 11 kW			
24V DC control system.			
24V DC solenoids.			
~1 - 1,5 sec. fast raising-EFO with optional hydraulic accumulator, and may differ depending on the number of bollards in the set and the raising height.			
IP55 - Hydraulic Power Unit (optionally electronics control unit with IP67 protection box), IP68 - Hydraulic Piston			
-5°C / +55°C (opt. -30°C / +70°C) operating temperature.			
10 m R2 type (double wire braided mesh) hydraulic hose.			
40 - 120 lt capacity oil tank with magnetic metal collector and suction filter.			
Oil level and temperature indicator.			
Electrostatic powder coated over galvanised steel (opt. stainless steel) hydraulic power unit (HPU) cabinet			
External inputs/outputs (e.g. loop detector, safety sensor, traffic light, remote control, etc.).			
IP67 magnetic sensor for barrier position and traffic signalisation.			
Audio signal during lowering and raising operation.			
Automatic / manual programmable passage authorisation (with optional loop detector).			
Manual lowering valve.			
Hot dip galvanised steel main body.			
25 mm aluminium top lid.			
Free standing piston connection structure avoiding load on the piston during vehicle passage.			
Manual control button unit, that is suitable for outdoor use, with 3 functions.			
Emergency stop button.			
360° visible red flashing LED indicators			
Red (opt. white or yellow) reflecting strips.			
Interconnecting hoses in case of installations of multiple bollard posts.			
Easy installation with installation apparatus.			

## Optional Features and Accessories

Hydraulic accumulator for EFO-fast raise up, Hand pump for manual raising, 24V DC motor in case of power failure (minimum 60 - 100 movements), oil heater (for oil tank), oil cooler, heater for electronic components, submersible pump, traffic light (Ø200/300 mm, red-green LED, electrostatic powder coated over 304 grade stainless steel body), traffic light pole (electrostatic powder coated over hot dip galvanised steel), loop detector (double contact), safety sensors (with 50 cm height poles), IP67 box (for PLC, SMPS, connectors etc. inside power unit), wireless remote control (receiver and transmitter), external buttons, PLC with diagnostic display, oil level sensor, different product dimensions, 304 - 316 grade stainless steel sleeve.



## BOLLARDS

### FIXED (STATIC) BOLLARDS

#### 82 DEEP EXCAVATED SERIES

82 HBD/12 (ANTI-TERROR / HEAVY DUTY - FIXED MODEL)

83 HBD/8 (ANTI-TERROR / HEAVY DUTY - FIXED MODEL)

84 RBD/4 (REINFORCED - FIXED MODEL)

#### 85 SHALLOW MOUNT SERIES

86 HBD/12 SHLW (ANTI-TERROR / HEAVY DUTY - FIXED - SHALLOW MOUNT MODEL)

87 HBD/8 SHLW (ANTI-TERROR / HEAVY DUTY - FIXED - SHALLOW MOUNT MODEL)

90 RBD/4 SHLW (REINFORCED - FIXED - SHALLOW MOUNT MODEL)

#### 91 TRAFFIC REGULATION SERIES

92 TBD (TRAFFIC REGULATION - FIXED MODEL)

#### 93 REMOVABLE BOLLARDS

94 TBD RMB REMOVABLE BOLLARD

# HBD/12 BOLLARD

(Anti-terror / Heavy Duty - Fixed Model)



**M50 (K12)**  
**ASTM F2656-15**



## Dimensions (mm)

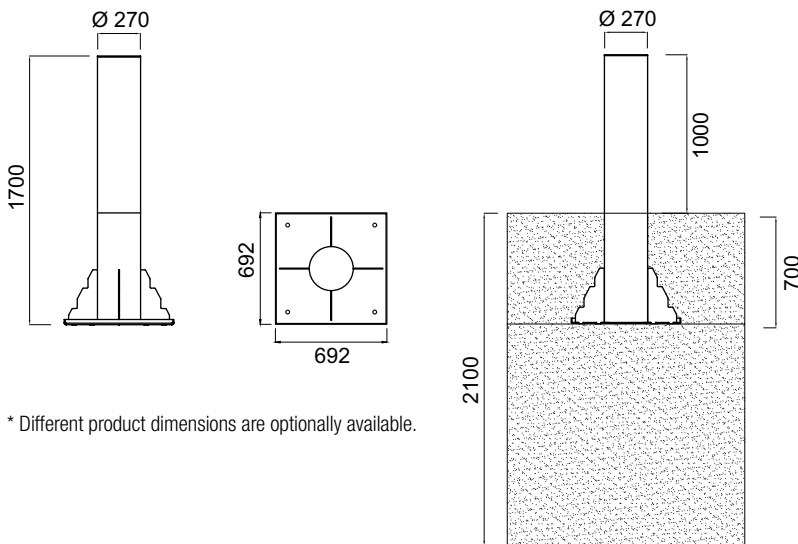

\* Different product dimensions are optionally available.

## Technical Features

### Crash / Impact Rating

Crash tested and certified according to ASTM F2656-15 at M50 (K-12) level (HBD 275 S 100) also designed and produced to withstand impacts mentioned below:

Standard	Vehicle Type	Weight	Speed
PAS 68	N3	7500 kg	80 km/h (50 mph)
IWA 14-1	N3C	7200 kg	80 km/h (50 mph)

(Please contact for applicable product dimensions.)

### Bollard Structure

Ø270 mm, solid steel and composite filled, 10 mm thick hot dip galvanised steel pipe, electrostatic powder coated in RAL9006 (optionally in other RAL colors) impact surface.  
Special star-formed, 10 mm solid steel bar infilled inner structure for impact absorption distributed evenly to the whole body.  
Furnished with red (opt. white or yellow) reflecting strips.  
Includes 4 adjustment bolts for easy leveling, with an anchor plate of 692x692 mm welded to the impact pipe and 4 vertical anchor supports welded around the impact pipe.  
Designed so that no vehicle crashing effect can displace it after embedded into the ground.

### Optional Features and Accessories

Demountability feature (please contact for impact resistance info), demountable aluminium (electrostatic powder coated in body color or 304/316 grade stainless steel) bollard top lid with 360° visible red flashing LED indicators, stainless steel sleeve (304/316 grade), different colors, different product dimensions.

### Installation

Easy levelling with 4 bolts and installation with C30 grade concrete and steel rebar reinforcement. Ground levelling and preparation works shall be carried on before pouring the concrete. Allowable bearing value of the ground shall be minimum 1/2 kg/cm<sup>2</sup>, if not, works shall be carried on to fulfil. Installation shall be done according to the manufacturer's instructions.



# HBD/8 BOLLARD

(Anti-terror / Heavy Duty - Fixed Model)



## Dimensions (mm)

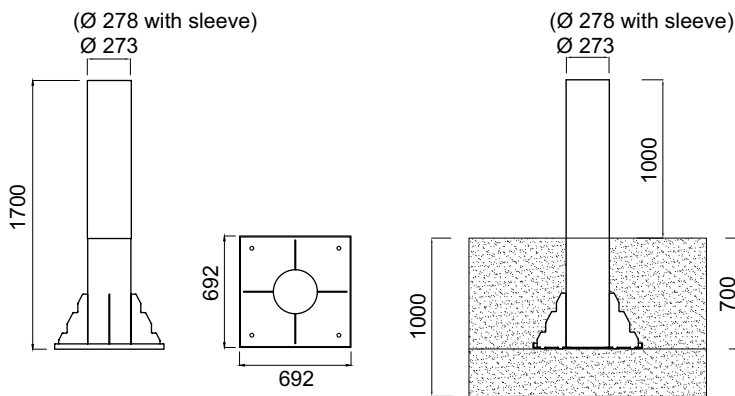

\* Different product dimensions are optionally available.

## Technical Features

### Crash / Impact Rating

Designed and produced to withstand impacts mentioned below:

Standard	Vehicle Type	Weight	Speed
ASTM F2656	M, C7, (K-8)	7200 kg	64 km/h (40 mph)
PAS 68	N2, N3	7500 kg	64 km/h (40 mph)
IWA 14-1	N2A, N2B, N3C	7200 kg	64 km/h (40 mph)

(Please contact for applicable product dimensions.)

### Bollard Structure

Ø273 mm (Ø278 mm with sleeve) solid steel and composite infilled, 10 mm thick hot dip galvanised solid steel pipe, electrostatic powder coated in RAL9006 (optionally in other RAL colors) impact surface.

Special triangular-formed, 10 mm solid steel bar infilled inner structure for impact absorption distributed evenly to the whole body.

Furnished with red (opt. white or yellow) reflecting strips.

Includes 4 adjustment bolts for easy leveling, with an anchor plate of 692x692 mm welded to the impact pipe and 4 vertical anchor supports welded around the impact pipe.

Designed so that no vehicle crashing effect can displace it after embedded into the ground.

### Optional Features and Accessories

Demountability feature (please contact for impact resistance info), demountable aluminium (electrostatic powder coated in body color or 304/316 grade stainless steel) bollard top lid with 360° visible red flashing LED indicators, stainless steel sleeve (304/316 grade), different colors, different product dimensions.

### Installation

Easy levelling with 4 bolts and installation with C30 grade concrete and steel rebar reinforcement. Ground levelling and preparation works shall be carried on before pouring the concrete. Allowable bearing value of the ground shall be minimum 1/2 kg/cm<sup>2</sup>, if not, works shall be carried on to fulfil. Installation shall be done according to the manufacturer's instructions.

# RBD/4 BOLLARD

## (Reinforced - Fixed Model)



### Dimensions (mm)

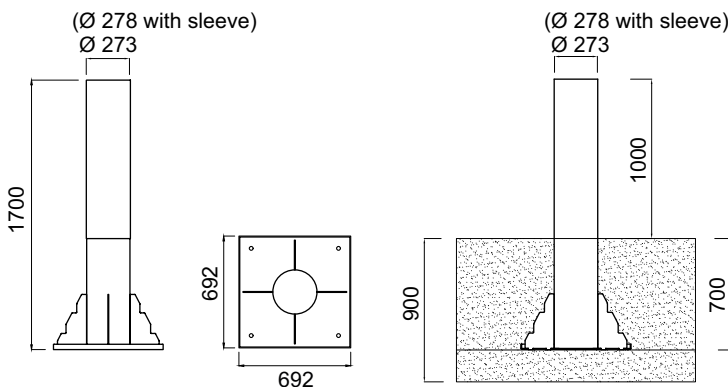

\* Different product dimensions are optionally available.

### Technical Features

#### Crash / Impact Rating

Designed and produced to withstand impacts mentioned below:

Standard	Vehicle Type	Weight	Speed
ASTM F2656	M, C7 (K-4)	6800, 7200 kg	48 km/h (30 mph)
PAS 68	N2, N3	7500 kg	48 km/h (30 mph)
IWA 14-1	N2A, N2B, N3C	7200 kg	48 km/h (30 mph)

(Please contact for applicable product dimensions.)

#### Bollard Structure

Ø273 mm (Ø278 mm with sleeve), 10 mm thick hot dip galvanised solid steel pipe, electrostatic powder coated in RAL9006 (optionally in other RAL colors) impact surface and 10 mm thick impact absorbing panel reinforced interior.

Furnished with red (opt. white or yellow) reflecting strips.

Includes 4 adjustment bolts for easy leveling, with an anchor plate of 692x692 mm welded to the impact pipe and 4 vertical anchor supports welded around the impact pipe.

Designed so that no vehicle crashing effect can displace it after embedded into the ground.

#### Optional Features and Accessories

Demountability feature (please contact for impact resistance info), demountable aluminium (electrostatic powder coated in body color or 304/316 grade stainless steel) bollard top lid with 360° visible red flashing LED indicators, stainless steel sleeve (304/316 grade), different colors, different product dimensions.

#### Installation

Easy levelling with 4 bolts and installation with C30 grade concrete and steel rebar reinforcement. Ground levelling and preparation works shall be carried on before pouring the concrete. Allowable bearing value of the ground shall be minimum 1/2 kg/cm<sup>2</sup>, if not, works shall be carried on to fulfil. Installation shall be done according to the manufacturer's instructions.



## BOLLARDS

### SHALLOW MOUNT SERIES

- 86 HBD/12 SHLW (ANTI-TERROR / HEAVY DUTY - FIXED - SHALLOW MOUNT MODEL)
- 87 HBD/8 SHLW (ANTI-TERROR / HEAVY DUTY - FIXED - SHALLOW MOUNT MODEL)
- 90 RBD/4 SHLW (REINFORCED - FIXED - SHALLOW MOUNT MODEL)

### 91 TRAFFIC REGULATION SERIES

- 92 TBD (TRAFFIC REGULATION - FIXED MODEL)

### 93 REMOVABLE BOLLARDS

- 94 TBD RMB REMOVABLE BOLLARD

# HBD/12 SHLW BOLLARD

(Anti-terror / Heavy Duty - Fixed - Shallow Mount Model)

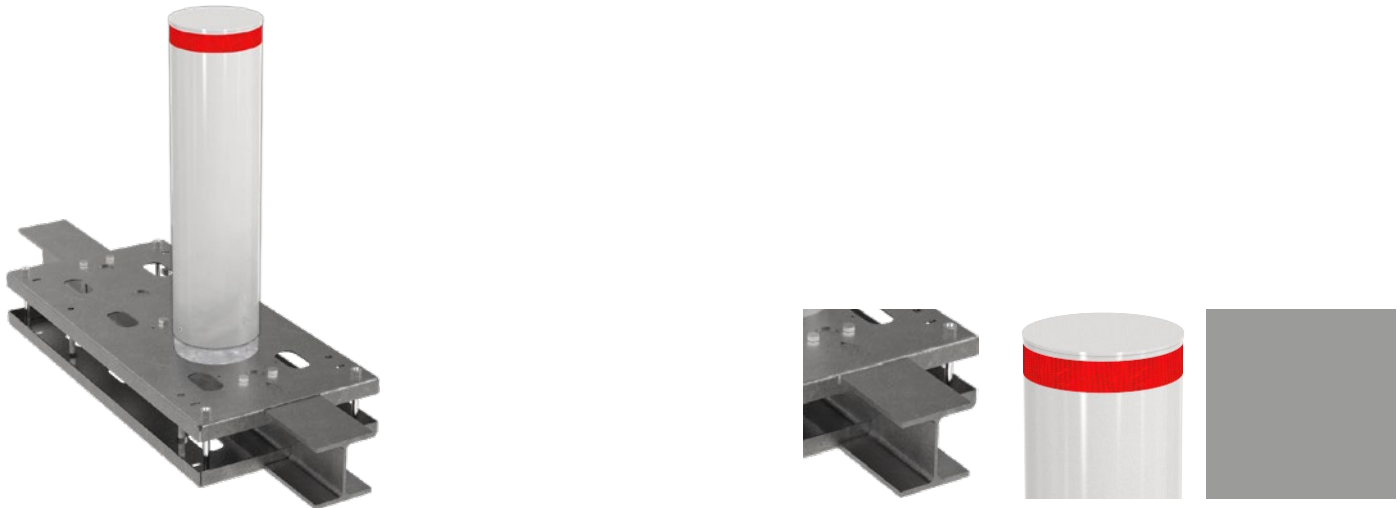

## Dimensions (mm)

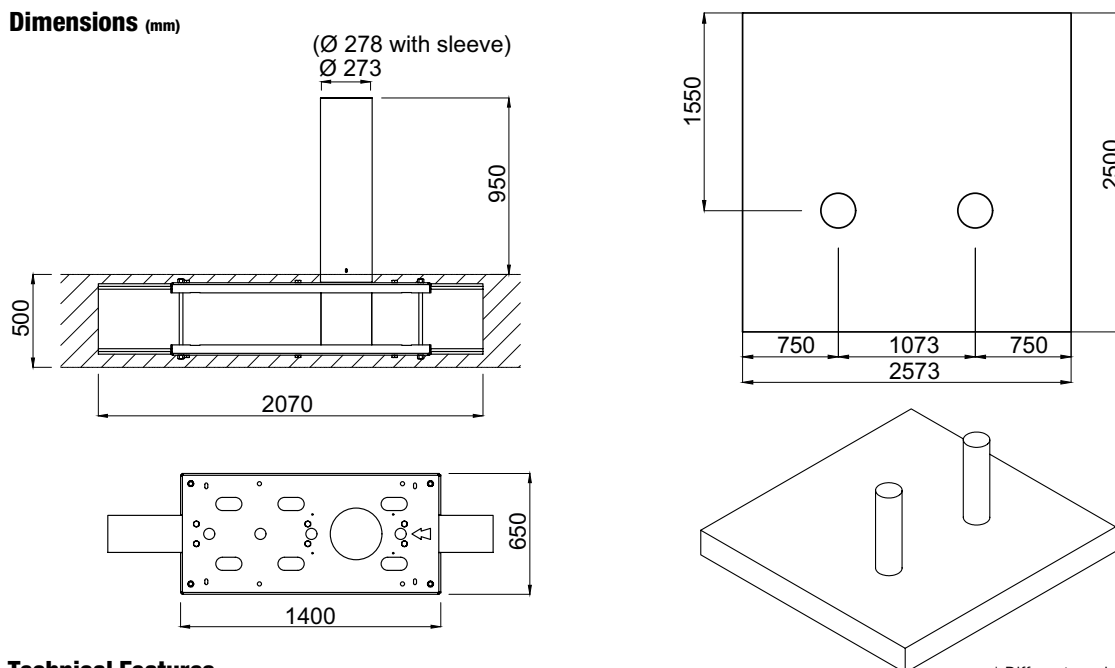

\* Different product dimensions are optionally available.

## Technical Features

### Crash / Impact Rating

Designed and produced to withstand impacts mentioned below:

Standard	Vehicle Type	Weight	Speed
ASTM F2656	M, C7 (K-12)	6800, 7200 kg	80 km/h (50 mph)
PAS 68	N3	7500 kg	80 km/h (50 mph)
IWA 14-1	N3C	7200 kg	80 km/h (50 mph)

(Please contact for applicable product dimensions.)

### Bollard Structure

950 mm high bollard pipe is made of  $\varnothing 273$  mm ( $\varnothing 278$  mm with sleeve), 10 mm thick hot dip galvanised solid steel pipe with a reinforced design.

Special star-formed, 10 mm solid steel bar and composite infilled inner structure for impact absorption distributed evenly to the whole body and increasing resistance.

Impact surface is painted in RAL9006 (optionally in other RAL colors).

Designed so that no vehicle crashing effect can displace it after embedded into the ground.

Furnished with red (opt. white or yellow) reflecting strips.

Bollard contains high resistant anchorage structure through 2 anchor plates with concrete immersion slits at the top and bottom, strengthened with "HEB" beams in the impact direction and adjustment bolts for leveling at 4 areas.

Underground elements are fixed together by wedge type, 10.9 grade bolted and welded connection for utmost resistance reinforcement.

### Optional Features and Accessories

Demountability feature (please contact for impact resistance info), demountable aluminium (electrostatic powder coated in body color or 304/316 grade stainless steel) bollard top lid with 360° visible red flashing LED indicators, stainless steel sleeve (304/316 grade), different colors, different product dimensions.

### Installation

Easy levelling with 4 bolts and installation to 500 mm shallow depth with steel rebar reinforcement and C35 grade concrete through ground mounting plate containing concrete immersion slits. Ground levelling and preparation works shall be carried on before pouring the concrete.

Allowable bearing value of the ground shall be minimum 1/2 kg/cm<sup>2</sup>, if not, works shall be carried on to fulfil. Installation shall be done according to the manufacturer's instructions. Minimum 2 bollard posts shall be installed for above mentioned crash/impact rating compliance.



# HBD/8 SHLW BOLLARD

CAME  ÖZAK

(Anti-terror / Heavy Duty - Fixed - Shallow Mount Model)



**PAS 68 (N3)**  
**IWA 14 (N3C)**  
**ASTM F2656 (C740)**

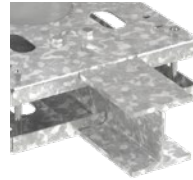

## Dimensions (mm)

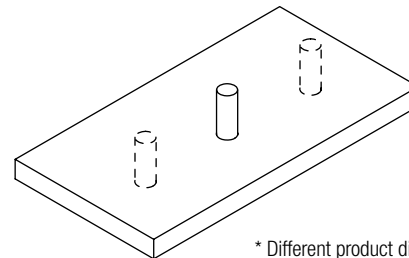
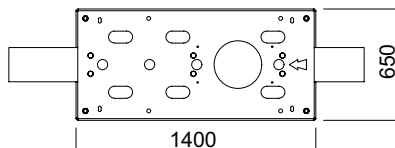
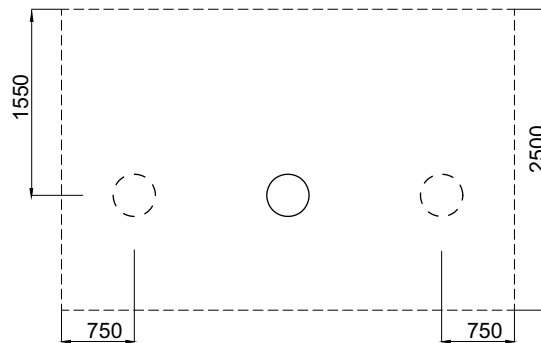
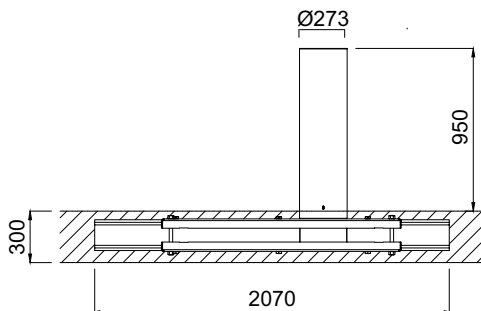

\* Different product dimensions are optionally available.

## Technical Features

### Crash / Impact Rating

Crash tested and certified according to:  
IWA 14-1:2013 Bollard V/7200[N3C]/64,  
PAS68:2013 Bollard V/7500[N3]/64, and  
ASTM F2656-18 C750/7200 standards (HBD 275 S 95/8 SRF model).

### Bollard Structure

950 mm high bollard pipe is made of Ø273 mm, 10 mm thick hot dip galvanised solid steel pipe with a reinforced design. Special star-formed, 10 mm solid steel bar and composite infilled inner structure for impact absorption distributed evenly to the whole body and increasing resistance. Impact surface is painted in RAL9006 (optionally in other RAL colors). Designed so that no vehicle crashing effect can displace it after embedded into the ground. Furnished with red (opt. white or yellow) reflecting strips. Bollard contains high resistant anchorage structure through 2 anchor plates with concrete immersion slits at the top and bottom, strengthened with "HEB" beams in the impact direction and adjustment bolts for leveling at 4 areas. Underground elements are fixed together by wedge type, 10.9 grade bolted and welded connection for utmost resistance reinforcement.

### Optional Features and Accessories

Demountability feature (please contact for impact resistance info), demountable aluminium (electrostatic powder coated in body color or 304/316 grade stainless steel) bollard top lid with 360° visible red flashing LED indicators, stainless steel sleeve (304/316 grade), different colors, different product dimensions.

### Installation

Easy levelling with 4 bolts and installation to 300 mm shallow depth with steel rebar reinforcement and C30 grade concrete through ground mounting plate containing concrete immersion slits. Ground levelling and preparation works shall be carried on before pouring the concrete. Allowable bearing value of the ground shall be minimum 1/2 kg/cm<sup>2</sup>, if not, works shall be carried on to fulfil. Installation shall be done according to the manufacturer's instructions.







# RBD/4 SHLW BOLLARD

(Reinforced - Fixed - Shallow Mount Model)



## Dimensions (mm)

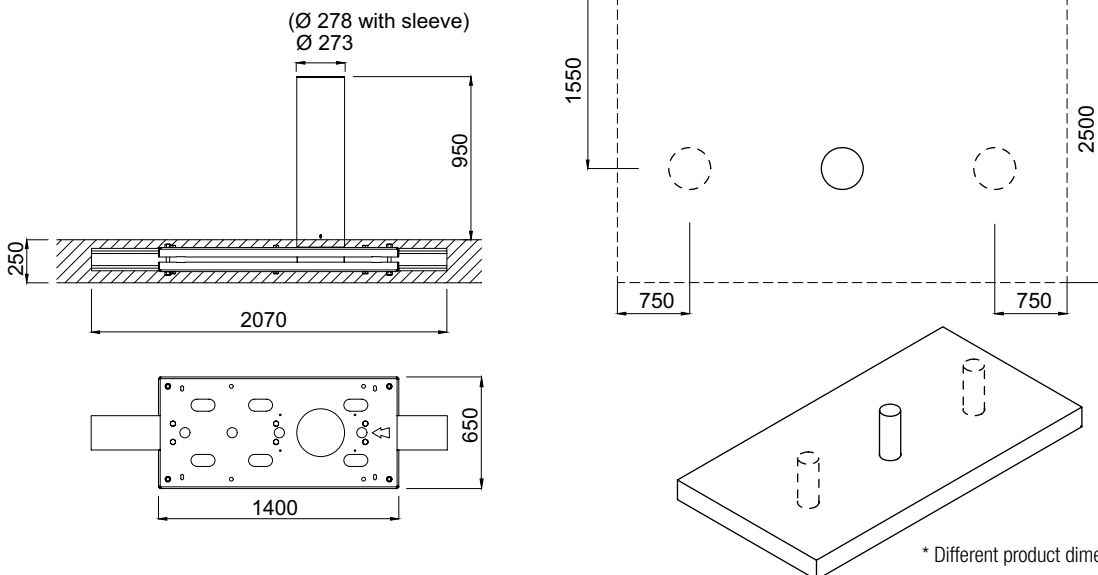

\* Different product dimensions are optionally available.

## Technical Features

### Crash / Impact Rating

Designed and produced to withstand impacts mentioned below:

Standard	Vehicle Type	Weight	Speed
ASTM F2656	M, C7 (K-4)	6800, 7200 kg	48 km/h (30 mph)
PAS 68	N2, N3	7500 kg	48 km/h (30 mph)
IWA 14-1	N2A, N2B, N3C	7200 kg	48 km/h (30 mph)

(Please contact for applicable product dimensions.)

### Bollard Structure

950 mm high bollard pipe is made of Ø273 mm (Ø278 mm with sleeve), 10 mm thick hot dip galvanised solid steel pipe with a reinforced design.

10 mm solid steel bar infilled inner structure for impact absorption distributed evenly to the whole body and increasing resistance.

Impact surface is painted in RAL9006 (optionally in other RAL colors).

Designed so that no vehicle crashing effect can displace it after embedded into the ground.

Furnished with red (opt. white or yellow) reflecting strips.

Bollard contains high resistant anchorage structure through 2 anchor plates with concrete immersion slits at the top and bottom, strengthened with "HEB" beams in the impact direction and adjustment bolts for leveling at 4 areas.

Underground elements are fixed together by wedge type, 10.9 grade bolted and welded connection for utmost resistance reinforcement.

### Optional Features and Accessories

Demountability feature (please contact for impact resistance info), demountable aluminium (electrostatic powder coated in body color or 304/316 grade stainless steel) bollard top lid with 360° visible red flashing LED indicators, stainless steel sleeve (304/316 grade), different colors, different product dimensions.

### Installation

Easy levelling with 4 bolts and installation to 250 mm shallow depth with steel rebar reinforcement and C35 grade concrete through ground mounting plate containing concrete immersion slits. Ground levelling and preparation works shall be carried on before pouring the concrete. Allowable bearing value of the ground shall be minimum 1/2 kg/cm<sup>2</sup>, if not, works shall be carried on to fulfil. Installation shall be done according to the manufacturer's instructions.



## BOLLARDS

### TRAFFIC REGULATION SERIES

92 TBD (TRAFFIC REGULATION - FIXED MODEL)

### 93 REMOVABLE BOLLARDS

94 TBD RMB REMOVABLE BOLLARD

# TBD BOLLARD

## (Traffic Regulation - Fixed Model)



### Dimensions (mm)

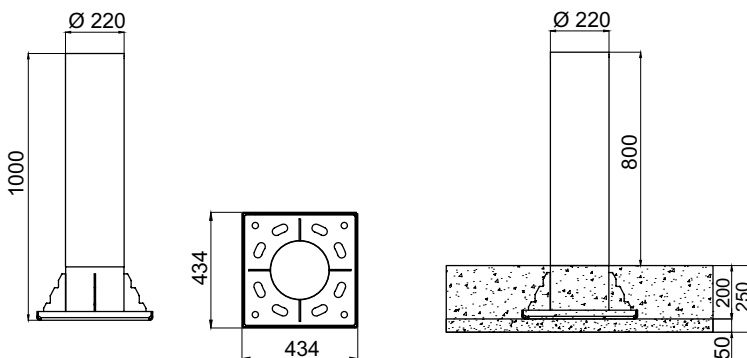

\* Different product dimensions are optionally available.

### Technical Features

#### Crash / Impact Rating

#### Bollard Structure

800 mm high bollard pipe is made of Ø220 mm, 6 mm thick hot dip galvanised steel pipe electrostatic powder coated in RAL9006 (optionally in other RAL colors).

Furnished with red (opt. white or yellow) reflecting strips.

#### Optional Features and Accessories

Demountability feature (please contact for impact resistance info), demountable aluminium (electrostatic powder coated in body color or 304/316 grade stainless steel) bollard top lid with 360° visible red flashing LED indicators, stainless steel sleeve (304/316 grade), different colors, different product dimensions.

#### Installation

Easy levelling with 4 bolts and easy installation with steel rebar reinforcement and C30 grade concrete through ground mounting plate. Ground levelling and preparation works shall be carried on before pouring the concrete. Allowable bearing value of the ground shall be minimum 1/2 kg/cm<sup>2</sup>, if not, works shall be carried on to fulfil. Installation shall be done according to the manufacturer's instructions.



## BOLLARDS

### REMOVABLE BOLLARDS

94

TBD RMB REMOVABLE BOLLARD

# TBD RMB REMOVABLE BOLLARD

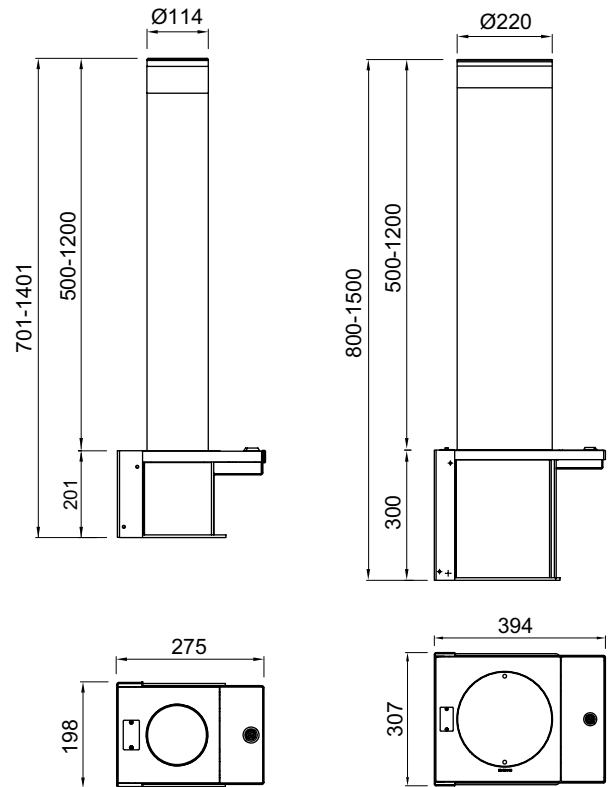
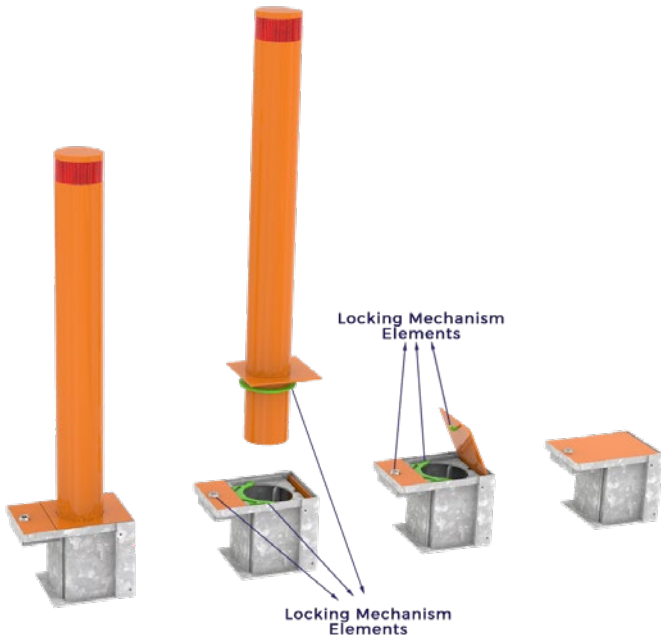

\* Different raising heights are optionally available.  
\* Fixed versions fitting to the removable bollards are also available.

## Technical Features

### Crash / Impact Rating

#### Bollard Structure

900 mm high bollard pipe is made of Ø114 / 220 mm, 2 mm thick hot dip galvanised steel pipe electrostatic powder coated in RAL9006 (optionally in other RAL colors or 304 grade stainless steel).  
Furnished with red (opt. white or yellow) reflecting strips.  
Hot dip galvanised steel underground unit in a reinforced structure contains road level lid (in body color).  
Road level lid is designed to retract into underground unit when the bollard is in use avoiding risk of getting lost.  
Road level lid can be closed and locked when the bollard is removed providing a plain road surface.

#### Locking Mechanism

Hot dip galvanised, special design in sliding form locking mechanism with special key.  
Locking mechanism locks the body when the bollard is in use, and locks the road level lid when the bollard is not in use.

#### Optional Features and Accessories

360° visible red flashing LED indicators, 304 grade stainless steel, different colors, different materials.

#### Installation

Easy installation with ground mounting plate, C30 grade concrete and steel rebar reinforcement. Ground levelling and preparation works shall be carried on before pouring the concrete. Installation shall be done according to the manufacturer's instructions.





جميرا  
من منتج  
جزيرة السعديات  
Jumeirah  
at SAADIYAT ISLAND  
RESORT











**CAME İ ÖZAK**





# CAME ÖZAK

## ÖZAK GEÇİŞ TEKNOLOJİLERİ

**SAN. TİC. A.Ş.**  
Köseköy, Çuhane Cd.  
N:130 41080 Kartepe  
Kocaeli / TÜRKİYE  
Tel.: +90 262 373 48 48

## CORPORATE HEADQUARTERS

**CAME S.p.A.**  
Via Martiri della Libertà, 15  
31030 Dosson di Casier  
Treviso - ITALY

## MANUFACTURING COMPANIES

**CAME GO S.r.l.**  
Pordenone, ITALY

**CAME PARKARE GROUP S.L.**  
Barcelona, SPAIN

**CAME URBACO**  
Vedene, FRANCE

**ENTROTEC Limited**  
Livingston, UK

**KEY MANAGEMENT SYSTEMS Limited**  
Buckinghamshire, UK

**NEPOS SISTEMAS DE CONTROLE E AUTOMAÇÃO EM ESTACIONAMENTO E TRÁFEGO LTDA**  
São Paulo, BRAZIL

## ÖZAK GEÇİŞ TEKNOLOJİLERİ

**SAN. TİC. A.Ş.**  
Kocaeli, TURKEY

## COMMERCIAL BRANCHES EUROPE

**ITALY**  
CAME ITALIA S.r.l.  
Treviso

**BELGIUM**  
CAME BENELUX S.A.  
Lessines

**CROATIA**  
CAME ADRIATIC d.o.o.  
Kastav

**FRANCE**  
CAME FRANCE S.A.S.  
Paris

**GERMANY**  
CAME DEUTSCHLAND GmbH  
Stuttgart

**IRELAND**  
CAME BPT IRELAND LIMITED  
Dublin

**THE NETHERLANDS**  
CAME NEDERLAND B.V.  
Breda

**POLAND**  
CAME POLAND Sp. z o.o.  
Warszawa

**PORTUGAL**  
CAME PORTUGAL,  
UNIPESSOAL, LDA  
Lisbon

**RUSSIA**  
UMC RUS LLC  
Moscow

**SPAIN**  
CAME SPAIN S.A.  
Madrid

**THE UNITED KINGDOM**  
CAME BPT UK LIMITED  
Nottingham

## COMMERCIAL BRANCHES ASIA

**INDIA**  
CAME INDIA AUTOMATION  
SOLUTIONS Pvt. Ltd.  
New Delhi

**U.A.E.**  
CAME GULF FZCO  
Dubai

## COMMERCIAL BRANCHES AMERICAS

**BRAZIL**  
CAME DO BRASIL, INDÚSTRIA,  
IMPORTAÇÃO, EXPORTAÇÃO,  
COMÉRCIO E SERVIÇOS DE  
AUTOMAÇÃO LTDA  
São Paulo

**MEXICO**  
CAME AUTOMATISMOS §  
DE MEXICO S. DE R.L. DE C.V.  
Mexico City

**PERÚ**  
CAME PARKARE PERU S.A.C.  
Lima

**USA**  
CAME AMERICAS AUTOMATION LLC  
Miami, FL

**CANADA**  
CAME CANADA Inc.  
Toronto



© CAME SPA - KODENSUE23 - 2023 -EN  
ANY FULL OR PARTIAL REPRODUCTION OF THIS DOCUMENT IS PROHIBITED.  
CAME RESERVES THE RIGHT TO MAKE ANY CHANGES TO THIS DOCUMENT AT ANY TIME.



CAME S.p.A.  
has the following Quality, Environmental and Safety  
certifications:  
ISO 9001  
ISO 14001  
ISO 45001

**CAME**  | Official Sponsor of **aprilia**  
RACING